

ISO/TC 45/SC 4

Secretariat: DSM

Voting begins on:  
2020-05-08

Voting terminates on:  
2020-07-03

---

---

## Rubber- or plastics-coated fabrics — Determination of bursting strength —

### Part 2: Hydraulic method

*Supports textiles revêtus de caoutchouc ou de plastique —  
Détermination de la résistance à l'éclatement —*

*Partie 2: Méthode hydraulique*

**ITeH STANDARD PREVIEW**  
(standard@iteh.ai)  
Full standard/catalog/standards.iso/7283/eea-  
<https://standards.iteh.ai/catalog/standards.iso/7283/eea-473a-4612-8a93-dfb5ea0c845d/iso/fdis-3303-2>

RECIPIENTS OF THIS DRAFT ARE INVITED TO SUBMIT, WITH THEIR COMMENTS, NOTIFICATION OF ANY RELEVANT PATENT RIGHTS OF WHICH THEY ARE AWARE AND TO PROVIDE SUPPORTING DOCUMENTATION.

IN ADDITION TO THEIR EVALUATION AS BEING ACCEPTABLE FOR INDUSTRIAL, TECHNOLOGICAL, COMMERCIAL AND USER PURPOSES, DRAFT INTERNATIONAL STANDARDS MAY ON OCCASION HAVE TO BE CONSIDERED IN THE LIGHT OF THEIR POTENTIAL TO BECOME STANDARDS TO WHICH REFERENCE MAY BE MADE IN NATIONAL REGULATIONS.

**ISO/CEN PARALLEL PROCESSING**



Reference number  
ISO/FDIS 3303-2:2020(E)

**iTeh STANDARD PREVIEW**  
**(standards.iteh.ai)**  
Full standard:  
<https://standards.iteh.ai/catalog/standards/sist/b7283eea-473a-4612-8a93-dfb5ea0c845d/iso-fdis-3303-2>



**COPYRIGHT PROTECTED DOCUMENT**

© ISO 2020

All rights reserved. Unless otherwise specified, or required in the context of its implementation, no part of this publication may be reproduced or utilized otherwise in any form or by any means, electronic or mechanical, including photocopying, or posting on the internet or an intranet, without prior written permission. Permission can be requested from either ISO at the address below or ISO's member body in the country of the requester.

ISO copyright office  
CP 401 • Ch. de Blandonnet 8  
CH-1214 Vernier, Geneva  
Phone: +41 22 749 01 11  
Fax: +41 22 749 09 47  
Email: [copyright@iso.org](mailto:copyright@iso.org)  
Website: [www.iso.org](http://www.iso.org)

Published in Switzerland

# Contents

	Page
Foreword.....	iv
Introduction.....	v
<b>1 Scope.....</b>	<b>1</b>
<b>2 Normative references.....</b>	<b>1</b>
<b>3 Terms and definitions.....</b>	<b>1</b>
<b>4 Principle.....</b>	<b>1</b>
<b>5 Apparatus and reagents.....</b>	<b>1</b>
<b>6 Calibration.....</b>	<b>5</b>
<b>7 Sampling.....</b>	<b>5</b>
<b>8 Preparation of test piece.....</b>	<b>5</b>
<b>9 Time-interval between manufacture and testing.....</b>	<b>5</b>
<b>10 Atmosphere for conditioning and testing.....</b>	<b>5</b>
10.1 For conditioning.....	5
10.2 For testing.....	6
<b>11 Procedure.....</b>	<b>6</b>
<b>12 Test report.....</b>	<b>6</b>
<b>Bibliography.....</b>	<b>7</b>

**iTeh STANDARD PREVIEW**  
 (standards.iteh.ai)  
 Full standard:  
<https://standards.iteh.ai/catalog/standards/sist/b7283eaa-473a-4612-8a93-dfb5ea0c845d/iso-fdis-3303-2>

## Foreword

ISO (the International Organization for Standardization) is a worldwide federation of national standards bodies (ISO member bodies). The work of preparing International Standards is normally carried out through ISO technical committees. Each member body interested in a subject for which a technical committee has been established has the right to be represented on that committee. International organizations, governmental and non-governmental, in liaison with ISO, also take part in the work. ISO collaborates closely with the International Electrotechnical Commission (IEC) on all matters of electrotechnical standardization.

The procedures used to develop this document and those intended for its further maintenance are described in the ISO/IEC Directives, Part 1. In particular, the different approval criteria needed for the different types of ISO documents should be noted. This document was drafted in accordance with the editorial rules of the ISO/IEC Directives, Part 2 (see [www.iso.org/directives](http://www.iso.org/directives)).

Attention is drawn to the possibility that some of the elements of this document may be the subject of patent rights. ISO shall not be held responsible for identifying any or all such patent rights. Details of any patent rights identified during the development of the document will be in the Introduction and/or on the ISO list of patent declarations received (see [www.iso.org/patents](http://www.iso.org/patents)).

Any trade name used in this document is information given for the convenience of users and does not constitute an endorsement.

For an explanation of the voluntary nature of standards, the meaning of ISO specific terms and expressions related to conformity assessment, as well as information about ISO's adherence to the World Trade Organization (WTO) principles in the Technical Barriers to Trade (TBT) see [www.iso.org/iso/foreword.html](http://www.iso.org/iso/foreword.html).

This document was prepared by Technical Committee ISO/TC 45, *Rubber and rubber products*, Subcommittee SC 4, *Products (other than hoses)*, in collaboration with the European Committee for Standardization (CEN) Technical Committee CEN/TC 248, *Textiles and textile products*, in accordance with the Agreement on technical cooperation between ISO and CEN (Vienna Agreement).

This second edition cancels and replaces the first edition (ISO 3303-2:2012), which has been technically revised.

The main changes compared to the previous edition are as follows:

- the title of [Clause 5](#) has been changed to “Apparatus and reagents”;
- reagents have been added to [Clause 5](#);
- in [5.1.1.3](#) and bibliography, EN 12332-2 has been deleted as it has been replaced with this document;
- in [5.6](#), blotting paper has been added;
- the preparation of wet test pieces has been specified in [8.3](#);
- the procedure for wet test pieces has been specified in [11.6](#).

A list of all parts in the ISO 3303 series can be found on the ISO website.

Any feedback or questions on this document should be directed to the user's national standards body. A complete listing of these bodies can be found at [www.iso.org/members.html](http://www.iso.org/members.html).

## Introduction

The bursting strength of coated fabrics is often used as a measure of the multidirectional modulus of the material, as opposed to tensile properties which only provide guidance to the coated-fabric strength in one plane. In addition, bursting strength is more appropriate for testing materials prone to necking, such as coated fabrics with knitted substrates.

The method described in this document, which employs an elastic diaphragm, is the more common method used in burst testing and is more suitable for the testing of lighter and medium-weight coated fabrics. Two aperture sizes are specified to allow the use of commercially available instruments, although results from the different machines might not be comparable.

**iTeh STANDARD PREVIEW**  
(standards.iteh.ai)

Full standard:  
<https://standards.iteh.ai/catalog/standards/sist/b7283eea-473a-4612-8a93-dfb5ea0c845d/iso-fdis-3303-2>

**iTeh STANDARD PREVIEW**  
**(standards.iteh.ai)**

Full standard:  
<https://standards.iteh.ai/catalog/standards/sist/b7283eea-473a-4612-8a93-dfb5ea0c845d/iso-fdis-3303-2>

# Rubber- or plastics-coated fabrics — Determination of bursting strength —

## Part 2: Hydraulic method

**WARNING** — Persons using this document should be familiar with normal laboratory practice. This document does not purport to address all of the safety problems, if any, associated with its use. It is the responsibility of the user to establish appropriate safety and health practices and to ensure compliance with any national regulatory conditions.

### 1 Scope

This document specifies a method for the determination of the bursting strength of rubber - or plastics - coated fabrics, using one of two types of diaphragm bursting tester, designated type A and B, both operated by hydraulic pressure.

The type A test machine is applicable to materials having bursting strengths ranging from 350 kPa to 5 500 kPa and the type B test machine is applicable to materials of bursting strengths ranging from 70 kPa to 1 400 kPa.

### 2 Normative references

The following documents are referred to in the text in such a way that some or all of their content constitutes requirements of this document. For dated references, only the edition cited applies. For undated references, the latest edition of the referenced document (including any amendments) applies.

ISO 2231:1989, *Rubber- or plastics-coated fabrics — Standard atmospheres for conditioning and testing*

### 3 Terms and definitions

No terms and definitions are listed in this document.

ISO and IEC maintain terminological databases for use in standardization at the following addresses:

- ISO Online browsing platform: available at <https://www.iso.org/obp>
- IEC Electropedia: available at <http://www.electropedia.org/>

### 4 Principle

A test piece is securely clamped around its edges between an upper and lower clamp. A diaphragm fitted beneath the lower clamp is gradually stretched into a dome by forcing fluid at a constant rate into a chamber under the diaphragm, thus causing it to make contact with, and apply pressure to, the test piece. The pressure of the fluid and the height of the dome at failure of the test piece are recorded.

### 5 Apparatus and reagents

**5.1 Testing machine**, of type A (see 5.1.1) or type B (see 5.1.2). In the case of materials for which the bursting strength specification allows either type of test machine to be used, it is recommended that the

customer and supplier mutually agree upon the test machine to be employed, as the test result from one type of test machine is not necessarily comparable with that from the other type.

NOTE Test machines of this type are often called Mullen burst testers. Such a tester is described in detail in ISO 2759.

**5.1.1 Type A test machine** (see [Figure 1](#)), measurement range between 350 kPa and 5 500 kPa, comprising the elements specified in [5.1.1.1](#) to [5.1.1.3](#).

**5.1.1.1 Clamping system**, for clamping the test piece firmly and with uniform loading between two plane, parallel, annular surfaces which are smooth (but not polished) and include grooves as shown in [Figure 1](#), which also specifies the dimensions of the clamping system. One clamping plate is held in a swivel joint or similar device so as to ensure that the clamping pressure is distributed evenly. Under the load used for testing, the circular openings in the two clamping faces shall be concentric to within 0,25 mm and the clamping surfaces shall be flat and parallel.

**5.1.1.2 Diaphragm**, circular in shape, made of natural or synthetic rubber clamped securely, before the test begins, with its upper surface recessed about 5,5 mm relative to the upper surface of the lower clamp. The material and construction of the diaphragm shall be such that the pressure required to cause the diaphragm to bulge beyond the upper surface of the lower clamp is as follows:

- bulge height 10 mm  $\pm$  0,2 mm, pressure range: 170 kPa to 220 kPa;
- bulge height 18 mm  $\pm$  0,2 mm, pressure range: 250 kPa to 350 kPa.

**5.1.1.3 Hydraulic system**, to apply an increasing hydraulic pressure to the inside of the diaphragm until the test piece bursts. The pressure shall be generated by a motor-driven piston forcing a suitable liquid (e.g. pure glycerol, low-viscosity silicone oil or ethylene glycol containing corrosion inhibitor) which is compatible with the diaphragm material against the inner surface of the diaphragm. The hydraulic system and the fluid used shall be free from air bubbles. The pumping rate shall be 170 ml/min  $\pm$  20 ml/min.

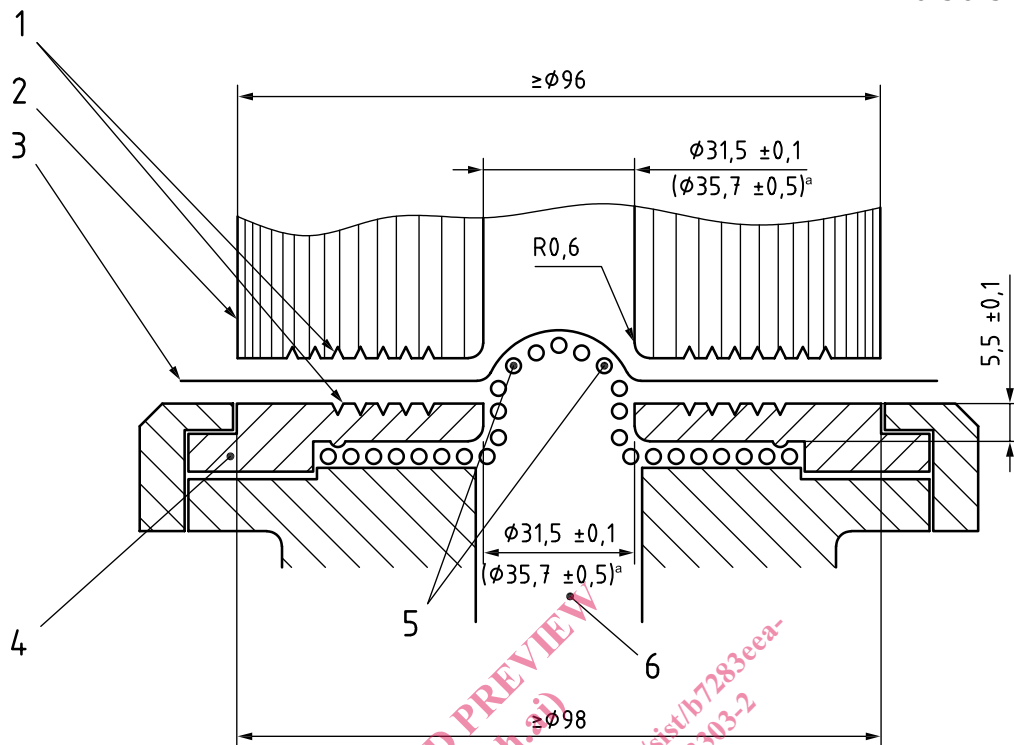

Dimensions in millimetres

**Key**

- 1 continuous-spiral 60° V-groove or a series of concentric 60° V-grooves
- 2 upper clamp
- 3 test piece
- 4 lower clamp
- 5 rubber diaphragm
- 6 pressure chamber

<sup>a</sup> The diameter of the cylindrical bore through the upper and lower clamps is 35,7 mm, giving a clamped area of 10 cm<sup>2</sup>.

**Figure 1 — Type A test machine**

**5.1.2 Type B test machine** (see [Figure 2](#)), measurement range between 70 kPa and 1 400 kPa, comprising the elements specified in [5.1.2.1](#) to [5.1.2.3](#).

**5.1.2.1 Clamping system**, for clamping the test piece firmly and uniformly between two annular, plane, parallel surfaces which shall be smooth (but not polished) and grooved as described in [Figure 2](#), which also gives the dimensions of the clamping system. One clamping plate shall be held in a swivel joint or similar device so as to ensure that the clamping pressure is distributed evenly. Under the load used for testing, the circular openings in the two clamping faces shall be concentric to within 0,25 mm and the clamping surfaces shall be flat and parallel.

**5.1.2.2 Diaphragm**, circular in shape, made of natural or synthetic rubber and 0,86 mm ± 0,06 mm thick, clamped securely, before the test begins, with its upper surface recessed about 3,5 mm relative to the upper surface of the lower clamp. The material and construction of the diaphragm shall be such that the pressure required to cause the diaphragm to bulge 9,0 mm ± 0,2 mm beyond the upper surface of the lower clamp is 30 kPa ± 5 kPa.

Diaphragms in use shall be regularly checked and changed should the bulge-height requirement be no longer met.