



SLOVENSKI STANDARD
oSIST prEN ISO 7436:2023
01-maj-2023

Vežni elementi - Navojni zatiči z zarezo in končino z obročastim rezilom (ISO/DIS 7436:2023)

Fasteners - Slotted set screws with cup point (ISO/DIS 7436:2023)

Verbindungselemente - Gewindestifte mit Schlitz und Ringschneide (ISO/DIS 7436:2023)

Fixations - Vis sans tête fendues à bout cuvette (ISO/DIS 7436:2023)

Ta slovenski standard je istoveten z: prEN ISO 7436

ICS:

21.060.10 Sorniki, vijaki, stebelni vijaki Bolts, screws, studs

oSIST prEN ISO 7436:2023

en,fr,de

DRAFT INTERNATIONAL STANDARD

ISO/DIS 7436

ISO/TC 2/SC 11

Secretariat: DIN

Voting begins on:
2023-03-08Voting terminates on:
2023-05-31

Fasteners — Slotted set screws with cup point

ICS: 21.060.10

iTeh STANDARD PREVIEW

(standards.iteh.ai)

[oSIST prEN ISO 7436:2023](https://standards.iteh.ai/catalog/standards/sist/21349597-400d-401b-93ff-f930e4187f80/osist-pren-iso-7436-2023)<https://standards.iteh.ai/catalog/standards/sist/21349597-400d-401b-93ff-f930e4187f80/osist-pren-iso-7436-2023>

This document is circulated as received from the committee secretariat.

THIS DOCUMENT IS A DRAFT CIRCULATED FOR COMMENT AND APPROVAL. IT IS THEREFORE SUBJECT TO CHANGE AND MAY NOT BE REFERRED TO AS AN INTERNATIONAL STANDARD UNTIL PUBLISHED AS SUCH.

IN ADDITION TO THEIR EVALUATION AS BEING ACCEPTABLE FOR INDUSTRIAL, TECHNOLOGICAL, COMMERCIAL AND USER PURPOSES, DRAFT INTERNATIONAL STANDARDS MAY ON OCCASION HAVE TO BE CONSIDERED IN THE LIGHT OF THEIR POTENTIAL TO BECOME STANDARDS TO WHICH REFERENCE MAY BE MADE IN NATIONAL REGULATIONS.

RECIPIENTS OF THIS DRAFT ARE INVITED TO SUBMIT, WITH THEIR COMMENTS, NOTIFICATION OF ANY RELEVANT PATENT RIGHTS OF WHICH THEY ARE AWARE AND TO PROVIDE SUPPORTING DOCUMENTATION.

ISO/CEN PARALLEL PROCESSING



Reference number
ISO/DIS 7436:2023(E)

© ISO 2023

iTeh STANDARD PREVIEW (standards.iteh.ai)

[oSIST prEN ISO 7436:2023](https://standards.iteh.ai/catalog/standards/sist/21349597-400d-401b-93ff-f930e4187f80/osist-pren-iso-7436-2023)

<https://standards.iteh.ai/catalog/standards/sist/21349597-400d-401b-93ff-f930e4187f80/osist-pren-iso-7436-2023>



COPYRIGHT PROTECTED DOCUMENT

© ISO 2023

All rights reserved. Unless otherwise specified, or required in the context of its implementation, no part of this publication may be reproduced or utilized otherwise in any form or by any means, electronic or mechanical, including photocopying, or posting on the internet or an intranet, without prior written permission. Permission can be requested from either ISO at the address below or ISO's member body in the country of the requester.

ISO copyright office
CP 401 • Ch. de Blandonnet 8
CH-1214 Vernier, Geneva
Phone: +41 22 749 01 11
Email: copyright@iso.org
Website: www.iso.org

Published in Switzerland

Contents

Page

Foreword.....	iv
1 Scope.....	1
2 Normative references.....	1
3 Terms and definitions.....	1
4 Dimensions.....	1
5 Requirements and reference International Standards.....	3
6 Marking and labelling.....	4
6.1 Marking on product.....	4
6.2 Labelling on package.....	4
7 Designation.....	4
Bibliography.....	6

iTeh STANDARD PREVIEW (standards.iteh.ai)

[oSIST prEN ISO 7436:2023](https://standards.iteh.ai/catalog/standards/sist/21349597-400d-401b-93ff-f930e4187f80/osist-pren-iso-7436-2023)

<https://standards.iteh.ai/catalog/standards/sist/21349597-400d-401b-93ff-f930e4187f80/osist-pren-iso-7436-2023>

ISO/DIS 7436:2023(E)

Foreword

ISO (the International Organization for Standardization) is a worldwide federation of national standards bodies (ISO member bodies). The work of preparing International Standards is normally carried out through ISO technical committees. Each member body interested in a subject for which a technical committee has been established has the right to be represented on that committee. International organizations, governmental and non-governmental, in liaison with ISO, also take part in the work. ISO collaborates closely with the International Electrotechnical Commission (IEC) on all matters of electrotechnical standardization.

The procedures used to develop this document and those intended for its further maintenance are described in the ISO/IEC Directives, Part 1. In particular, the different approval criteria needed for the different types of ISO documents should be noted. This document was drafted in accordance with the editorial rules of the ISO/IEC Directives, Part 2 (see www.iso.org/directives).

Attention is drawn to the possibility that some of the elements of this document may be the subject of patent rights. ISO shall not be held responsible for identifying any or all such patent rights. Details of any patent rights identified during the development of the document will be in the Introduction and/or on the ISO list of patent declarations received (see www.iso.org/patents).

Any trade name used in this document is information given for the convenience of users and does not constitute an endorsement.

For an explanation of the voluntary nature of standards, the meaning of ISO specific terms and expressions related to conformity assessment, as well as information about ISO's adherence to the World Trade Organization (WTO) principles in the Technical Barriers to Trade (TBT), see www.iso.org/iso/foreword.html.

This document was prepared by Technical Committee ISO/TC 2, *Fasteners*, Subcommittee SC 11, *Fasteners with metric external thread*.

This second edition cancels and replaces the first edition (ISO 7436:1983), which has been technically revised.

The main changes compared to the previous edition are as follows:

- for M4 and M5, $l = 5$ and $l = 6$ have been classified to short standard length separately in order to get 4,5 to 6 full thread turns;
- for stainless steel screws, grades A2 and A4 with hardness classes 12H and 21H have been added;
- non-ferrous metal screws have been deleted;
- surface condition “plain” has been changed to “as processed” for steel screws and to “Clean and bright” for stainless steel screws in [Table 2](#);
- non-electrolytically applied zinc flake coating has been added for steel screws, and “Passivated” has been added for stainless steel screws in [Table 2](#);
- the requirement of surface discontinuities has been added for steel screws in [Table 2](#);
- specifications for marking and labelling have been added as [Clause 6](#).

Any feedback or questions on this document should be directed to the user's national standards body. A complete listing of these bodies can be found at www.iso.org/members.html.

Fasteners — Slotted set screws with cup point

1 Scope

This document specifies the characteristics of slotted set screws with cup point, in steel and stainless steel, with coarse pitch threads M1,6 to M12 and with product grade A.

NOTE If in certain cases other specifications are requested, hardness classes and stainless steel grades can be selected from ISO 898-5, or ISO 3506-3, and dimensional options from ISO 888.

2 Normative references

The following documents are referred to in the text in such a way that some or all of their content constitutes requirements of this document. For dated references, only the edition cited applies. For undated references, the latest edition of the referenced document (including any amendments) applies.

ISO 225, *Fasteners — Bolts, screws, studs and nuts — Symbols and descriptions of dimensions*

ISO 888, *Bolts, screws and studs — Nominal lengths, and thread lengths for general purpose bolts*

ISO 898-5, *Mechanical properties of fasteners made of carbon steel and alloy steel — Part 5: Set screws and similar threaded fasteners with specified hardness classes — Coarse thread and fine pitch thread*

ISO 965-1, *ISO general purpose metric screw threads — Tolerances — Part 1: Principles and basic data*

ISO 3269, *Fasteners — Acceptance inspection*

ISO 3506-3, *Mechanical properties of corrosion-resistant stainless steel fasteners — Part 3: Set screws and similar fasteners not under tensile stress*

ISO 4042, *Fasteners — Electroplated coating systems*

ISO 4759-1, *Tolerances for fasteners — Part 1: Bolts, screws, studs and nuts — Product grades A, B and C*

ISO 6157-1, *Fasteners — Surface discontinuities — Part 1: Bolts, screws and studs for general requirements*

ISO 8991, *Designation system for fasteners*

ISO 8992, *Fasteners — General requirements for bolts, screws, studs and nuts*

ISO 10683, *Fasteners — Non-electrolytically applied zinc flake coating systems*

3 Terms and definitions

No terms and definitions are listed in this document.

ISO and IEC maintain terminological databases for use in standardization at the following addresses:

- ISO Online browsing platform: available at <https://www.iso.org/obp>
- IEC Electropedia: available at <https://www.electropedia.org/>

4 Dimensions

Dimensions shall be in accordance with [Figure 1](#) and with [Table 1](#).

ISO/DIS 7436:2023(E)

Symbols and descriptions of dimensions are defined in ISO 225.

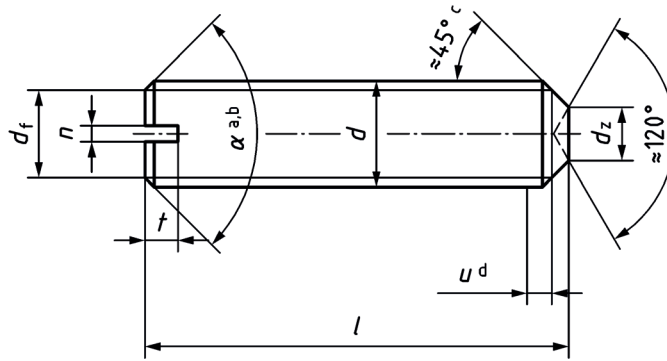

Key

- a For regular standard lengths, α_{ref} shall be 90° or 120° at the choice of the manufacturer.
- b For short standard lengths, α_{ref} shall be 120° in accordance with Table 1.
- c The 45° angle applies only to the portion of the point below the root diameter of the thread.
- d Incomplete thread $u \leq 2P$.

Figure 1 — Slotted set screw with cup point

Table 1 — Dimensions
(standards.iteh.ai)

Dimensions in millimetres

Thread, d	M1,6	M2	M2,5	M3	(M3,5)	M4	M5	M6	M8	M10	M12	
p^a	0,35	0,4	0,45	0,5	0,6	0,7	0,8	1	1,25	1,5	1,75	
d_f	Minor thread diameter											
d_z	min.	0,55	0,75	0,95	1,15	1,45	1,75	2,25	2,75	4,70	5,70	7,70
	max.	0,80	1,00	1,20	1,40	1,70	2,00	2,50	3,00	5,00	6,00	8,00
n	nom.	0,25	0,25	0,4	0,4	0,5	0,6	0,8	1	1,2	1,6	2
	min.	0,31	0,31	0,46	0,46	0,56	0,66	0,86	1,06	1,26	1,66	2,06
	max.	0,45	0,45	0,60	0,60	0,70	0,80	1,00	1,20	1,51	1,91	2,31
t	min.	0,56	0,64	0,72	0,80	0,96	1,12	1,28	1,60	2,00	2,40	2,80
	max.	0,74	0,84	0,95	1,05	1,21	1,42	1,63	2,00	2,50	3,00	3,60
l^b			Range of standard lengths between the stepped bold lines									
nom.	min.	max.										
2	1,8	2,2	c									
2,5	2,3	2,7		c								
3	2,8	3,2			c	c			Screws with too short lengths			
4	3,7	4,3				c	c					
5	4,7	5,3					c	c				
6	5,7	6,3						c	c			
8	7,7	8,3							c			

NOTE Sizes shown in brackets are non-preferred dimensions.

- a P is the pitch of the thread.
- b Minimum and maximum values in accordance with ISO 4759-1, but rounded to one decimal place.
- c For short standard lengths, α_{ref} shall be 120°.

Table 1 (continued)

Thread, <i>d</i>			M1,6	M2	M2,5	M3	(M3,5)	M4	M5	M6	M8	M10	M12
10	9,7	10,3										c	
12	11,6	12,4											c
(14)	13,6	14,4											
16	15,6	16,4											
20	19,6	20,4											
25	24,6	25,4											
30	29,6	30,4											
35	34,5	35,5											
40	39,5	40,5			Lengths by agreement in accordance with ISO 888								
45	44,5	45,5											
50	49,5	50,5											
55	54,4	55,6											
60	59,4	60,6											

NOTE Sizes shown in brackets are non-preferred dimensions.

^a *P* is the pitch of the thread.

^b Minimum and maximum values in accordance with ISO 4759-1, but rounded to one decimal place.

^c For short standard lengths, α_{ref} shall be 120°.

5 Requirements and reference International Standards

The requirements specified in the International Standards listed in Table 2 shall apply.

oSIST prEN ISO 7436:2023

https:// Table 2 — Requirements and reference International Standards

Material		Steel	Stainless steel
General requirements	International Standard	ISO 8992	
	Tolerance class	6g ^a	
Thread	International Standards	ISO 965-1	
	Hardness class symbol	14H, 22H	—
Mechanical properties	Grade and hardness class symbol	—	A1-12H, A2-12H, A4-12H, A2-21H and A4-21H
	International Standards	ISO 898-5	ISO 3506-3
Tolerances	Product grade	A	
	International Standard	ISO 4759-1	

^a Depending on the type of coating to be applied, another tolerance position of the thread may be specified for the uncoated fastener in accordance with the relevant coating standard.

^b See e.g. ISO 16048.

^c See e.g. ISO 6157-1.

Table 2 (continued)

Material	Steel	Stainless steel
Surface condition	As processed (no coating) Electroplated coatings as specified in ISO 4042 Non-electrolytically applied zinc flake coatings as specified in ISO 10683 Additional requirements or other finishes or coatings shall be agreed between the supplier and the purchaser	Clean and bright and/or Passivated ^b
Surface integrity	Limits for surface discontinuities specified in ISO 6157-1.	As agreed ^c
Acceptability	Acceptance inspection as specified in ISO 3269	
^a Depending on the type of coating to be applied, another tolerance position of the thread may be specified for the uncoated fastener in accordance with the relevant coating standard. ^b See e.g. ISO 16048. ^c See e.g. ISO 6157-1.		

6 Marking and labelling

6.1 Marking on product

Marking shall be:

- for steel fasteners, as specified in ISO 898-5,
- for stainless steel fasteners, as specified in ISO 3506-3.

6.2 Labelling on package

Labelling on the package shall be in accordance with ISO 898-5 or ISO 3506-3, and shall include at least:

- the reference to this document, i.e. ISO 7436;
- the thread size d and nominal length l ;
- the symbol of the hardness class for steel fasteners;
- the grade and symbol of the hardness class for stainless steel fasteners;
- the type of surface condition (finish and/or coating);
- the manufacturer's and/or distributor's identification and/or name;
- the manufacturing lot number as specified in ISO 1891-4;
- the quantity of pieces in the package.

7 Designation

The designation requirements as specified in ISO 8991 shall apply for all sizes, with:

- the symbol of the hardness class for steel fasteners, as specified in ISO 898-5,
- the grade and symbol of the hardness class for stainless steel fasteners, as specified in ISO 3506-3.