



~~Designation: E 45-05~~ Designation: E45 – 10

Standard Test Methods for Determining the Inclusion Content of Steel¹

This standard is issued under the fixed designation E45; the number immediately following the designation indicates the year of original adoption or, in the case of revision, the year of last revision. A number in parentheses indicates the year of last reapproval. A superscript epsilon (ϵ) indicates an editorial change since the last revision or reapproval.

This standard has been approved for use by agencies of the Department of Defense.

1. Scope

1.1 These test methods cover a number of recognized procedures for determining the nonmetallic inclusion content of wrought steel. Macroscopic methods include macroetch, fracture, step-down, and magnetic particle tests. Microscopic methods include five generally accepted systems of examination. In these microscopic methods, inclusions are assigned to a category based on similarities in morphology, and not necessarily on their chemical identity. Metallographic techniques that allow simple differentiation between morphologically similar inclusions are briefly discussed. While the methods are primarily intended for rating inclusions, constituents such as carbides, nitrides, carbonitrides, borides, and intermetallic phases may be rated using some of the microscopic methods. In some cases, alloys other than steels may be rated using one or more of these methods; the methods will be described in terms of their use on steels.

1.2 This practice covers procedures to perform JK-type inclusion ratings using automatic image analysis in accordance with microscopic methods A and D.

1.3 Depending on the type of steel and the properties required, either a macroscopic or a microscopic method for determining the inclusion content, or combinations of the two methods, may be found most satisfactory.

1.4 These test methods deal only with recommended test methods and nothing in them should be construed as defining or establishing limits of acceptability for any grade of steel.

~~1.5~~ 1.5 The values stated in SI units are to be regarded as the standard. Values in parentheses are conversions and are approximate.

1.6 *This standard does not purport to address all of the safety concerns, if any, associated with its use. It is the responsibility of the user of this standard to establish appropriate safety and health practices and determine the applicability of regulatory limitations prior to use.*

2. Referenced Documents

2.1 ~~ASTM Standards:~~

- ~~D96 Test Method for Water and Sediment in Crude Oil by Centrifuge Method (Field Procedure)~~ ASTM Standards:²
- E3 Guide for Preparation of Metallographic Specimens
- E7 Terminology Relating to Metallography
- E381 Method of Macroetch Testing Steel Bars, Billets, Blooms, and Forgings
- E709 Guide for Magnetic Particle Examination ~~Testing~~
- E768 ~~Practice~~ Guide for Preparing and Evaluating Specimens for Automatic Inclusion Assessment of Steel
- E1245 Practice for Determining the Inclusion or Second-Phase Constituent Content of Metals by Automatic Image Analysis
- E1444 Practice for Magnetic Particle ~~Examination~~ Testing
- E1951 Guide for Calibrating Reticles and Light Microscope Magnifications

2.2 SAE Standards:³

J422, Recommended Practice for Determination of Inclusions in Steel

2.3 Aerospace Material Specifications:³

AMS 2300, Premium Aircraft-Quality Steel Cleanliness: Magnetic Particle Inspection Procedure

AMS 2301, Aircraft Quality Steel Cleanliness: Magnetic Particle Inspection Procedure

¹ These test methods are under the jurisdiction of ASTM Committee E04 on Metallography and is the direct responsibility of Subcommittee E04.09 on Inclusions. Current edition approved Nov. 1, 2005. Published December 2005. Originally approved in 1942. Last previous edition approved in 2002 as E 45-97(2002). Current edition approved Nov. 1, 2010. Published December 2010. Originally approved in 1942. Last previous edition approved in 2005 as E45-05 ^{ε3}. DOI: 10.1520/E0045-10.

² For referenced ASTM standards, visit the ASTM website, www.astm.org, or contact ASTM Customer Service at service@astm.org. For Annual Book of ASTM Standards volume information, refer to the standard's Document Summary page on the ASTM website.

³ Available from Society of Automotive Engineers (SAE), 400 Commonwealth Dr., Warrendale, PA 15096-0001.

³ Available from SAE International (SAE), 400 Commonwealth Dr., Warrendale, PA 15096-0001, http://www.sae.org.

AMS 2303, Aircraft Quality Steel Cleanliness: Martensitic Corrosion-Resistant Steels Magnetic Particle Inspection Procedure
 AMS 2304, Special Aircraft-Quality Steel Cleanliness: Magnetic Particle Inspection Procedure

2.4 *ISO Standards:*⁴

ISO 3763, Wrought Steels—Macroscopic Methods for Assessing the Content of Nonmetallic Inclusions

ISO 4967, Steel—Determination of Content of Nonmetallic Inclusions—Micrographic Methods Using Standard Diagrams

2.5 *ASTM Adjuncts:*

Inclusions in Steel Plates I-r and II⁵

Four Photomicrographs of Low Carbon Steel⁶

3. Terminology

3.1 *Definitions:*

3.1.1 For definitions of terms used in this practice, see Terminology E-7E7.

~~3.1.2 Terminology E-7E-7~~

3.1.2 Terminology E7 includes the term *inclusion count*; since some methods of these test methods involve length measurements or conversions to numerical representations of lengths or counts, or both, the term *inclusion rating* is preferred.

3.2 *Definitions of Terms Specific to This Standard:*

3.2.1 *aspect ratio*—the length-to-width ratio of a microstructural feature.

3.2.2 *discontinuous stringer*—three or more Type B or C inclusions aligned in a plane parallel to the hot working axis and offset by no more than 15 µm, with a separation of less than 40 µm (0.0016 in.) between any two nearest neighbor inclusions.

3.2.3 *inclusion types*—for definitions of sulfide-, alumina-, and silicate-type inclusions, see Terminology E-7E-1951E7. Globular oxide, in some methods refers to isolated, relatively nondeformed inclusions with an aspect ratio not in excess of 2:1. In other methods, oxides are divided into deformable and nondeformable types.

3.2.4 *JK inclusion rating*—a method of measuring nonmetallic inclusions based on the Swedish Jernkontoret procedures; Methods A and D of these test methods are the principal JK rating methods, and Method E also uses the JK rating charts.

3.2.5 *stringer*—an individual inclusion that is highly elongated in the deformation direction or three or more Type B or C inclusions aligned in a plane parallel to the hot working axis and offset by no more than 15 µm, with a separation of less than 40 µm (0.0016 in.) between any two nearest neighbor inclusions.

3.2.6 *threshold setting*—isolation of a range of gray level values exhibited by one constituent in the microscope field.

3.2.7 *worst-field rating*—a rating in which the specimen is rated for each type of inclusion by assigning the value for the highest severity rating observed of that inclusion type anywhere on the specimen surface.

4. Significance and Use

4.1 These test methods cover four macroscopic and five microscopic test methods (manual and image analysis) for describing the inclusion content of steel and procedures for expressing test results.

4.2 Inclusions are characterized by size, shape, concentration, and distribution rather than chemical composition. Although compositions are not identified, Microscopic methods place inclusions into one of several composition-related categories (sulfides, oxides, and silicates—the last as a type of oxide). Paragraph 12.2.1 describes a metallographic technique to facilitate inclusion discrimination. Only those inclusions present at the test surface can be detected.

4.3 The macroscopic test methods evaluate larger surface areas than microscopic test methods and because examination is visual or at low magnifications, these methods are best suited for detecting larger inclusions. Macroscopic methods are not suitable for detecting inclusions smaller than about 0.40 mm (1/64 in.) in length and the methods do not discriminate inclusions by type.

~~4.4 The microscopic test methods are employed to characterize inclusions that form as a result of deoxidation or due to limited solubility in solid steel (indigenous inclusions). These inclusions are characterized by morphological type, that is, by size, shape, concentration, and distribution, but not specifically by composition. The microscopic methods are not intended for assessing the content of exogenous inclusions (those from entrapped slag or refractories).~~

4.4 The microscopic test methods are employed to characterize inclusions that form as a result of deoxidation or due to limited solubility in solid steel (indigenous inclusions). As stated in 1.1, these microscopic test methods rate inclusion severities and types based on morphological type, that is, by size, shape, concentration, and distribution, but not specifically by composition. These inclusions are characterized by morphological type, that is, by size, shape, concentration, and distribution, but not specifically by composition. The microscopic methods are not intended for assessing the content of exogenous inclusions (those from entrapped slag or refractories). In case of a dispute whether an inclusion is indigenous or exogenous, microanalytical techniques such as energy dispersive X-ray spectroscopy (EDS) may be used to aid in determining the nature of the inclusion. However, experience

⁴ Available from American National Standards Institute (ANSI), 25 W. 43rd St., 4th Floor, New York, NY 10036, <http://www.ansi.org>.

⁵ Available from ASTM Headquarters. Order ADJE004502.

⁵ Available from ASTM International Headquarters. Order Adjunct No. ADJE004502. Original adjunct produced in 1983..

⁶ Available from ASTM Headquarters. Order ADJE004501.

⁶ Available from ASTM International Headquarters. Order Adjunct No. ADJE004501. Original adjunct produced in 1983..

and knowledge of the casting process and production materials, such as deoxidation, desulfurization, and inclusion shape control additives as well as refractory and furnace liner compositions must be employed with the microanalytical results to determine if an inclusion is indigenous or exogenous

4.5 Because the inclusion population within a given lot of steel varies with position, the lot must be statistically sampled in order to assess its inclusion content. The degree of sampling must be adequate for the lot size and its specific characteristics. Materials with very low inclusion contents may be more accurately rated by automatic image analysis, which permits more precise microscopic ratings.

4.6 Results of macroscopic and microscopic test methods may be used to qualify material for shipment, but these test methods do not provide guidelines for acceptance or rejection purposes. Qualification criteria for assessing the data developed by these methods can be found in ASTM product standards or may be described by purchaser-producer agreements. By agreements between producer and purchaser, this practice may be modified to count only certain inclusion types and thicknesses, or only those inclusions above a certain severity level, or both. Also, by agreement, qualitative practices may be used where only the highest severity ratings for each inclusion type and thickness are defined or the number of fields containing these highest severity ratings are tabulated.

4.7 These test methods are intended for use on wrought metallic structures. While a minimum level of deformation is not specified, the test methods are not suitable for use on cast structures or on lightly worked structures.

4.8 Guidelines are provided to rate inclusions in steels treated with rare earth additions or calcium-bearing compounds. When such steels are evaluated, the test report should describe the nature of the inclusions rated according to each inclusion category (A, B, C, D).

4.9 In addition to the Practice E45 JK ratings, basic (such as used in Practice E-1245E1245) stereological measurements (for example, the volume fraction of sulfides and oxides, the number of sulfides or oxides per square millimeter, the spacing between inclusions, and so forth) may be separately determined and added to the test report, if desired for additional information. This practice, however, does not address the measurement of such parameters.

MACROSCOPIC METHODS

5. Macroscopical Test Methods Overview

5.1 Summary:

5.1.1 *Macro-etch Test*—The macro-etch test is used to indicate inclusion content and distribution, usually in the cross section or transverse to the direction of rolling or forging. In some instances, longitudinal sections are also examined. Tests are prepared by cutting and machining a section through the desired area and etching with a suitable reagent. A solution of one part hydrochloric acid and one part water at a temperature of 71 to 82°C (160 to 180°F) is widely used. As the name of this test implies, the etched surface is examined visually or at low magnification for inclusions. Details of this test are included in Method E-381E381. The nature of questionable indications should be verified by microscopic examination or other means of inspection.

5.1.1.1 Sulfides are revealed as pits when the standard etchant described in 5.1.1 is used.

5.1.1.2 Only large oxides are revealed by this test method.

5.1.2 *Fracture Test*—The fracture test is used to determine the presence and location of inclusions as shown on the fracture of hardened slices approximately 9 to 13 mm ($\frac{3}{8}$ to $\frac{1}{2}$ in.) thick. This test is used mostly for steels where it is possible to obtain a hardness of approximately 60 HRC and a fracture grain size of 7 or finer. Test specimens should not have excessive external indentations or notches that guide the fracture. It is desirable that fracture be in the longitudinal direction approximately across the center of the slice. The fractured surfaces are examined visually and at magnifications up to approximately ten diameters, and the length and distribution of inclusions is noted. Heat tinting, or blueing, will increase visibility of oxide stringers. ISO 3763 provides a chart method for fracture surface inclusion ratings. In some instances, indications as small as 0.40 mm ($\frac{1}{64}$ in.) in length are recorded.

5.1.3 *Step-Down Method*—The step-down test method is used to determine the presence of inclusions on machined surfaces of rolled or forged steel. The test sample is machined to specified diameters below the surface and surveyed for inclusions under good illumination with the unaided eye or with low magnification. In some instances, test samples are machined to smaller diameters for further examination after the original diameters are inspected. This test is essentially used to determine the presence of inclusions 3 mm ($\frac{1}{8}$ in.) in length and longer.

5.1.4 *Magnetic Particle Method*—The magnetic particle method is a variation of the step-down method for ferromagnetic materials in which the test sample is machined, magnetized, and magnetic powder is applied. Discontinuities as small as 0.40 mm ($\frac{1}{64}$ in.) in length create magnetic leakage fields that attract the magnetic powder, thereby outlining the inclusion. See Practice E-1444E1444 and Guide E-709E709 on magnetic particle examinations for more details of the procedure. Refer to Aerospace Materials Specifications AMS 2300, AMS 2301, AMS 2303, and AMS 2304.

5.2 Advantages:

5.2.1 These test methods facilitate the examination of specimens with large surface areas. The larger inclusions in steel, which are the main concern in most cases, are not uniformly distributed and the spaces between them are relatively large, so that the chances of revealing them are better when larger specimens are examined.

5.2.2 Specimens for macroscopic examination may be quickly prepared by machining and grinding. A highly polished surface

is not necessary. The macroscopic methods are sufficiently sensitive to reveal the larger inclusions.

5.3 Disadvantages:

5.3.1 These test methods do not distinguish among the different inclusion shapes.

5.3.2 They are not suitable for the detection of small globular inclusions or of chains of very fine elongated inclusions.

5.3.3 The magnetic particle method can lead to incorrect interpretation of microstructural features such as streaks of retained austenite, microsegregation, or carbides in certain alloys; this is particularly likely if high magnetization currents are employed.

MICROSCOPIC METHODS

6. Microscopic Test Methods Overview

6.1 Microscopic methods are used to characterize the size, distribution, number, and type of inclusions on a polished specimen surface. This may be done by examining the specimen with a light microscope and reporting the types of inclusions encountered, accompanied by a few representative photomicrographs. This method, however, does not lend itself to a uniform reporting style. Therefore, standard reference charts depicting a series of typical inclusion configurations (size, type, and number) were created for direct comparison with the microscopic field of view. A method using image analysis to make these comparisons has also been developed.

6.2 Various reference charts of this nature have been devised such as the JK chart⁷ and the SAE chart found in SAE Recommended Practice J422 of the SAE Handbook. The microscopic methods in Test Methods E45 use refined comparison charts based on these charts. Method A (Worst Fields), Method D (Low Inclusion Content) and Method E (SAM Rating) use charts based on the JK chart while Method C (Oxides and Silicates) uses the SAE chart. ISO Standard 4967 also uses the JK chart.

6.3 No chart can represent all of the various types and forms of inclusions. The use of any chart is thus limited to determining the content of the most common types of inclusions, and it must be kept in mind that such a determination is not a complete metallographic study of inclusions.

6.4 An alternate to comparison (chart) methods such as Methods A, C and D⁸ may be found in Method B. Method B (Length) is used to determine inclusion content based on length. Only inclusions 0.127 mm (0.005 in.) or longer are recorded regardless of their type. From this method one may obtain data such as length of the longest inclusion and average inclusion length. In addition, photomicrographs may also be taken to characterize the *background inclusions* that were not long enough to measure.

6.5 The advantages of the microscopic methods are:

6.5.1 Inclusions can be characterized as to their size, type, and number.

6.5.2 Extremely small inclusions can be revealed.

6.6 A disadvantage of the microscopic methods is that individual rating fields are very small (0.50 mm²). This limits the practical size of the specimen, as it would simply take a prohibitive number of fields to characterize a large specimen. The result obtained by a microscopic characterization of the inclusions in a large section is governed by chance if local variations in the inclusion distribution are substantial. The end use of the product determines the importance of the microscopic results. Experience in interpreting these results is necessary in order not to exaggerate the importance of small inclusions in some applications.

6.7 In determining the inclusion content, it is important to realize that, whatever method is used, the result actually applies only to the areas of the specimens that were examined. For practical reasons, such specimens are relatively small compared with the total amount of steel represented by them. For the inclusion determination to have any value, adequate sampling is just as necessary as a proper method of testing.

6.8 Steel often differs in inclusion content not only from heat to heat, but also from ingot to ingot in the same heat and even in different portions of the same ingot. It is essential that the unit lot of steel, the inclusion content of which is to be determined, shall not be larger than one heat. Sufficient samples should be selected to represent the lot adequately. The exact sampling procedure should be incorporated in the individual product requirements or specifications. For semifinished products, the specimens should be selected after the material has been sufficiently cropped and suitable discards made. If the locations of the different ingots and portions of ingots in the heat cannot be identified in the lot being tested, random sampling should involve a greater number of test specimens for an equivalent weight of steel. A value for the inclusion content of an isolated piece of steel, even if accurately determined, should not be expected to represent the inclusion content of the whole heat.

6.9 The size and shape of the wrought steel product tested has a marked influence on the size and shape of the inclusions. During reduction from the cast shape by rolling or forging, the inclusions are elongated and broken up according to the degree of reduction of the steel cross section. In reporting results of inclusion determinations, therefore, the size, shape, and method of manufacture of the steel from which the specimens were cut must be stated. In comparing the inclusion content of different steels, they must all be rolled or forged as nearly as possible to the same size and shape, and from cast sections of about the same size. Specimens cut lengthwise or parallel to the direction of rolling or forging shall be used.

6.10 It may be convenient, in order to obtain more readily comparable results, to forge coupons from larger billets. These forged sections may then be sampled in the same way as rolled sections. Exercise care, however, to crop specimens of sufficient length

⁷ The JK chart derives its name from its sponsors Jernkontoret, the Swedish Ironmasters Association.

⁸ Note that while these methods are called comparison chart methods, the procedure used may also consist of length measurements or counts of inclusions, or both.

from the billets for forging; otherwise, there is danger of the shear-dragged ends being incorporated in the specimens. Such distorted material will give a false result in the inclusion determination. To avoid this, it is helpful to saw the ends of the billet length for forging and to take the specimen from the middle of the forged length.

6.11 Several of the methods described in these test methods require that a specific area of the prepared surface of the specimen is surveyed, and all the significant inclusions observed be recorded and expressed in the results. The reported result for each specimen examined is, therefore, a more accurate representation of the inclusion content than a photomicrograph or diagram. A disadvantage of the Worst Field approach is that no such distribution of inclusion ratings is obtained.

6.12 To make comparisons possible between different heats and different parts of heats, the results shall be expressed in such a manner that an average for the inclusion content of the different specimens in the heat can be obtained. When the lengths of the inclusions are measured, the simplest number is that for the aggregate length of all the inclusions per area examined; however, it may be desirable not merely to add the lengths but also to weight the inclusions according to their individual lengths. The length of the largest inclusion found and the total number of inclusions may also be expressed.

7. Sampling

7.1 To obtain a reasonable estimate of inclusion variations within a lot, at least six locations, chosen to be as representative of the lot as possible, should be examined. In this context, a lot shall be defined as a unit of material processed at one time and subjected to similar processing variables. In no case should more than one heat be in the same lot. For example if a lot consists of one heat, sampling locations might be in the product obtained from the top and bottom of the first, middle, and last usable ingots in the pouring sequence. For strand cast or bottom pour processing, a similar sampling plan per heat should be invoked.

7.2 For cases in which a definite location within a heat, ingot, or other unit lot is unknown, statistical random sampling with a greater number of specimens should be employed.

7.3 Ratings obtained will vary with the amount of reduction of the product. For materials acceptance or for comparison among heats, care must be taken to sample at the correct stage of processing.

8. Test Specimen Geometry

8.1 The minimum polished surface area of a specimen for the microscopic determination of inclusion content is 160 mm² (0.25 in.²). It is recommended that a significantly large area should be obtained so that the measurements may be made within the defined area away from the edges of the sample. The polished surface must be parallel to the longitudinal axis of the product. In addition, for flat-rolled products, the section shall also be perpendicular to the rolling plane; for rounds and tubular shapes, the section shall be in the radial direction. In all cases, the polished surface shall be parallel to the hot-working axis. Studies have demonstrated that inclusion length measurements are significantly affected if the plane of polish is angled more than 6° from the longitudinal hot-working direction.⁹

8.1.1 Sections less than 0.71 mm in thickness shall not be analyzed using Test Methods E45.

8.2 *Thick Section (Product Section Size Greater than 9.5 mm (0.375 in.) Thick, Such as Forgings, Billet, Bar, Slab, Plate, and Pipe):* <https://standards.iteh.ai/catalog/standards/sist/466a2b3e-392f-4590-816e-3aa95e23b6ee/astm-e45-10>

8.2.1 For wide products, the one-quarter point along the product width is commonly used to provide representative material.

8.2.2 For round sections, the manner of cutting a specimen from a 38 mm (1.5-in.) diameter section is shown in Fig. 3. A disk at least 12 mm (0.474 in.) thick is cut from the product. The quarter-section indicated in Fig. 3 is cut from the disk and the shaded area is polished. Thus the specimen extends at least 12 mm along the length of the product from the outside to the center.

8.2.3 For large sections, each specimen shall be taken from the mid-radius location, as shown by the shaded area in Fig. 4. The specimen face to be polished extends at least 12 mm parallel to the longitudinal axis of the billet and at least 19 mm (0.75 in.)

⁹ Allmand, T. R., and Coleman, D. S., "The Effect of Sectioning Errors on Microscopic Determinations of Non-Metallic Inclusions in Steels," *Metals and Materials*, Vol 7, 1973, pp. 280–283.

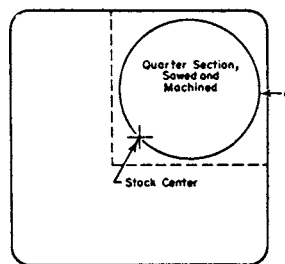

NOTE 1—This method is also applicable to round sections.

NOTE 2—*a* denotes surface removal.

FIG. 1 Quarter Section Specimen from Square Section for Magnetic Particle Test, Machine Only

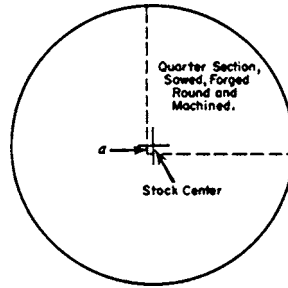

NOTE 1—Method also applicable to square sections.
 NOTE 2—*a* denotes distance equal to surface removal.

FIG. 2 Quarter Section Specimen from Round Section for Magnetic Particle Test, Forging and Machining

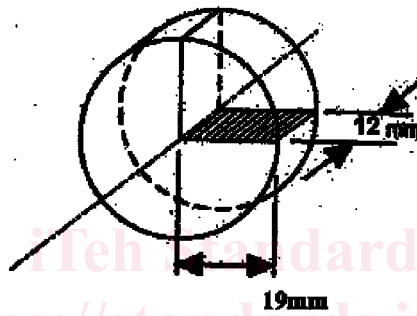

NOTE 1—Inch-pound equivalents: 12 mm = 0.47 in.; 19 mm = 0.75 in.
FIG. 3 Specimen from 1½-in. (38.1 mm) Round Section for Microscopic Test

<https://standards.iteh.ai/catalog/standards/sist/166a2b3e-392f-4590-816e-3aa95e23b6ce/astm-e45-10>

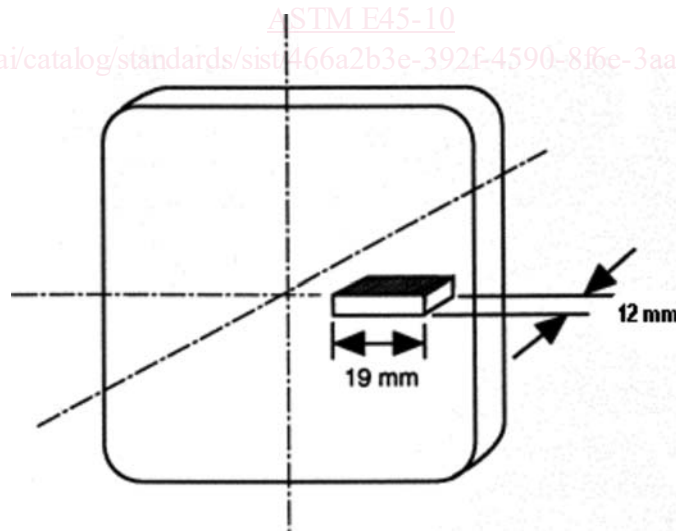

FIG. 4 Specimen from Large Bar or Billet for Microscopic Test

in the longitudinal radial plane, with the polished face midway between the center and the outside of the billet. Such midway sampling is used to decrease the number of specimens polished and examined. Other areas, such as the center and the surface, may be examined as well, provided the sampling procedure used is stated in the results. A billet or bar about 50 to 100 mm (2 to 4 in.) round or square is the preferred size from which specimens should be taken; however, larger or smaller sizes may be used, provided the product sizes are reported with the results.

8.3 *Thin Sections (Product Section Sizes 9.5 mm (0.375 in.) Thick or Less; Strip, Sheet, Rod, Wire, and Tubing)*—Full cross section longitudinal specimens shall be cut in accordance with the following plan:

8.3.1 For 0.95 to 9.5-mm (0.0375 to 0.375 in.) cross section thicknesses inclusively, a sufficient number of pieces from the same sampling point are mounted to provide approximately 160 mm² (0.25 in.²) of polished specimen surface. (Example: For a sheet 1.27 mm (0.050 in.) thick, select seven or eight longitudinal pieces uniformly across the sheet width to provide one specimen).

8.3.2 For cross section thicknesses less than 0.95 mm, ten longitudinal pieces from each sampling location shall be mounted to provide a suitable specimen surface for polishing. (Dependent on material thickness and piece length, the polished specimen area may be less than 160 mm². Because of practical difficulties in mounting a group of more than ten pieces, the reduced specimen area will be considered sufficient.) Note that when using the comparison procedures of Methods A, C, D and E, the thickness of the test specimen cross section should not be less than the defined minimum dimension of a single field of view. Therefore, the minimum thickness required is 0.71 mm for Methods A, D, and E, and 0.79 mm for Method C. Thinner sections should be rated by other means.

9. Preparation of Specimens

9.1 Methods of specimen preparation must be such that a polished, microscopically flat section is achieved in order that the sizes and shapes of inclusions are accurately shown. To obtain satisfactory and consistent inclusion ratings, the specimen must have a polished surface free of artifacts such as pitting, foreign material (for example, polishing media), and scratches. When polishing the specimen it is very important that the inclusions not be pitted, dragged, or obscured. Specimens must be examined in the as-polished condition, free from the effects of any prior etching (if used).

9.2 Metallographic specimen preparation must be carefully controlled to produce acceptable quality surfaces for both manual and image analysis. Guidelines and recommendations are given in Practice E-3E3, Test Methods E45, and Practice E-768E768.

9.3 Inclusion retention is generally easier to accomplish in hardened steel specimens than in the annealed condition. If inclusion retention is inadequate in annealed specimens, they should be subjected to a standard heat treatment cycle using a relatively low tempering temperature. After heat treatment, the specimen must be descaled and the longitudinal plane must be reground below any decarburization. This recommendation only applies to heat-treatable steel grades.

9.4 Mounting of specimens is not required if unmounted specimens can be properly polished.

10. Calibration and Standardization

10.1 Recommended calibration guidelines can be found in Guide E-1954E1951.

10.2 For image analysis, a stage micrometer and a ruler, both calibrated against devices traceable to a recognized national standards laboratory, such as the National Institute for Standards and Technology (NIST), are used to determine the magnification of the system and calibrate the system in accordance with the manufacturer's recommended procedure. For example, the ruler is superimposed over the magnified image of the stage micrometer on the monitor. The apparent (magnified) distance between two known points on the stage micrometer is measured with the ruler. The magnified distance is divided by the true distance to determine the screen magnification. The pixel dimensions can be determined from the number of pixels for a known horizontal or vertical dimension on the monitor. Divide the known length of a scale or mask by the number of pixels representing that length on the monitor to determine the pixel size for each possible screen magnification. Not all systems use square pixels. Determine the pixel dimensions in both horizontal and vertical orientations. Check the instruction manual to determine how corrections are made for those systems that do not use square pixels.

10.2.1 Follow the manufacturer's recommendations in adjusting the microscope light source and setting the correct level of illumination for the television video camera. For systems with 256 gray levels, the illumination is generally adjusted until the as-polished matrix surface is at level 254 and black is at zero.

10.2.2 For modern image analyzers with 256 gray levels, with the illumination set as described in 10.2.1, it is usually possible to determine the reflectance histogram of individual inclusions as an aid in establishing proper threshold settings to discriminate between oxides and sulfides. Oxides are darker and usually exhibit gray levels below about 130 on the gray scale while the lighter sulfides generally exhibit values between about 130 and 195. These numbers are not absolute and will vary somewhat for different steels and different image analyzers. After setting the threshold limits to discriminate oxides and sulfides, use the *flicker method* of switching back-and-forth between the live inclusion image and the detected (discriminated) image, over a number of test fields, to ensure that the settings are correct, that is, detection of sulfides or oxides by type and size is correct.

11. Classification of Inclusions and Calculation of Severities

11.1 In these microscopic methods, inclusions are classified into four categories (called Type) based on their morphology and two subcategories based on their width or diameter. Categories A-Sulfide Type, B-Alumina Type, C-Silicate Type and D-Globular Oxide Type define their shape while categories Heavy and Thin describe their thickness. Although the categories contain chemical names that imply knowledge of their chemical content, the ratings are based strictly on morphology. The chemical names associated with the various Types were derived from historical data collected on inclusions found in these shapes or morphologies. The four categories, or Types, are partitioned into Severity Levels based on the number or length of the particles present in a 0.50 mm² field of view. These Severity Levels and inclusion Types are depicted in Plate I-r and their numerical equivalents are found in Tables 1 and 2.

11.1.1 Type A and C inclusions are very similar in size and shape. Therefore, discrimination between these Types is aided by metallographic techniques. Type A-Sulfide are light gray while Type C-Silicate are black when viewed under brightfield

**TABLE 1 Minimum Values for Severity Level Numbers
(Methods A, D, and E)^{A,B}**

(mm (in.) at 100×, or count)				
Severity	A	B	C	D ^C
0.5	3.7(0.15)	1.7(0.07)	1.8(0.07)	1
1.0	12.7(0.50)	7.7(0.30)	7.6(0.30)	4
1.5	26.1(1.03)	18.4(0.72)	17.6(0.69)	9
2.0	43.6(1.72)	34.3(1.35)	32.0(1.26)	16
2.5	64.9(2.56)	55.5(2.19)	51.0(2.01)	25
3.0	89.8(3.54)	82.2(3.24)	74.6(2.94)	36
3.5	118.1(4.65)	114.7(4.52)	102.9(4.05)	49
4.0	149.8(5.90)	153.0(6.02)	135.9(5.35)	64
4.5	189.8(7.47)	197.3(7.77)	173.7(6.84)	81
5.0	223.0(8.78)	247.6(9.75)	216.3(8.52)	100

(µm (in.) at 1×, or count)				
Severity	A	B	C	D ^C
0.5	37.0(.002)	17.2(.0007)	17.8(.0007)	1
1.0	127.0(.005)	76.8(.003)	75.6(.003)	4
1.5	261.0(.010)	184.2(.007)	176.0(.007)	9
2.0	436.1(.017)	342.7(.014)	320.5(.013)	16
2.5	649.0(.026)	554.7(.022)	510.3(.020)	25
3.0	898.0(.035)	822.2(.032)	746.1(.029)	36
3.5	1181.0(.047)	1147.0(.045)	1029.0(.041)	49
4.0	1498.0(.059)	1530.0(.060)	1359.0(.054)	64
4.5	1898.0(.075)	1973.0(.078)	1737.0(.068)	81
5.0	2230.0(.088)	2476.0(.098)	2163.0(.085)	100

(mm/mm ² (in./in. ²), or count/mm ²)				
Severity	A	B	C	D ^C
0.5	0.074(1.88)	0.034(.864)	0.036(.914)	2
1.0	0.254(6.45)	0.154(3.91)	0.152(3.86)	8
1.5	0.522(3.64)	0.368(9.35)	0.352(8.94)	18
2.0	0.872(22.15)	0.686(17.32)	0.640(16.26)	32
2.5	1.298(32.97)	1.110(28.19)	1.020(25.91)	50
3.0	1.796(45.59)	1.644(41.76)	1.492(37.90)	72
3.5	2.362(59.99)	2.294(58.27)	2.058(52.27)	98
4.0	2.996(76.10)	3.060(77.72)	2.718(69.04)	128
4.0	2.996(76.10)	3.060(77.72)	2.718(69.04)	128
4.5	3.796(96.42)	3.946(100.2)	3.474(88.24)	162
5.0	4.460(113.3)	4.952(125.8)	4.326(109.9)	200

^A Note that length values in this table have been changed to be compatible with automated rating methods. The significant length changes occurred at minimum rating levels of 1/2 where manual methods are least accurate. Inclusion counts for Type D inclusions have also been revised. In this case, the changes are greatest for high counts, which are above the levels of material acceptance standards.

^B VanderVoort, G. F., and Wilson, R. K., "Nonmetallic Inclusions and ASTM Committee E04," *Standardization News*, Vol 19, May 1991, pp 28–37.

^C Maximum aspect ratio for Type D inclusions is $5:4 < 2$.

**TABLE 2 Inclusion Width and Diameter Parameters
(Methods A and D)^A**

Inclusion Type	Thin Series		Heavy Series	
	Width, min, µm (in.)	Width, max, µm (in.)	Width, min, µm (in.)	Width, max, µm (in.)
A	2 (.00008)	4 (.00016)	>4 (.00016)	12 (.0005)
B	2 (.00008)	9 (.00035)	>9 (.00035)	15 (.0006)
C	2 (.00008)	5 (.0002)	>5 (.0002)	12 (.0005)
D	2 (.00008)	8 (.0003)	>8 (.0003)	13 (.0005)

^A Any inclusion with maximum dimensions greater than the maximum for the Heavy Series must be reported as *oversized* accompanied with its actual dimensions.

illumination. Discrimination between these types may also be aided by viewing the questionable inclusions under darkfield or cross-polarized illumination where properly polished sulfide inclusions are dark and silicate inclusions appear luminescent.

11.2 The B-type stringers consist of a number (at least three) of round or angular oxide particles with aspect ratios less than 2 that are aligned nearly parallel to the deformation axis. Particles within $\pm 15 \mu\text{m}$ of the centerline of a B-type stringer are considered to be part of that stringer. The Type C-Silicate stringers consist of one or more highly elongated oxides with smooth surfaces aligned parallel to the deformation axis. Aspect ratios are generally high, ≥ 2 . The maximum permitted separation between particles in a stringer is $40 \mu\text{m}$. Any oxides that have aspect ratios < 2 , and are not part of a B- or C-type stringer, are

rated as D-types. No other shape restriction is applicable.

11.3 After the inclusions are categorized by Type, they must be categorized by thickness or diameter. Inclusion width parameters for classification into the Thin or Heavy category are listed in Table 2. An inclusion whose width varies from Thin to Heavy along its length shall be placed in the category that best represents its whole. That is to say, if more of its length falls into the Heavy range, classify it as Heavy. See 11.8 for instructions on reporting inclusions that exceed the limits of Table 1 or Table 2.

11.4 Inclusions thinner than the 2 μm minimum listed in Table 2 are not rated. That is, their lengths or numbers are not included in the determination of Severity.

11.5 After classification by type and thickness, the severity levels are determined for the inclusions within 0.50 mm² test areas based upon the total Type A sulfide lengths per field, the total Type B or C stringer lengths per field, and the number of isolated D-type inclusions per field. These values can be reported according to the length or number in each 0.50-mm² field or as the length per unit area or number per unit area (mm²), but the measurements must be made on contiguous 0.50 mm² test areas. Severities are calculated based on the limits given in Table 1. Note that these values are the minimum length or number for each class. In general, severity values (calculated as described below) are rounded downward to the nearest whole or half unit. For steels with particularly low inclusion contents, severity values may be rounded down to the nearest quarter or tenth value, per agreement between producer and purchaser. However, because of the way D inclusion counts are defined (for 1 inclusion, the severity is 0.5 and for 0 inclusions, the severity is 0), there can be no subdivisions between 0 and 0.5 severities.

11.6 Calculation of the severity number for Type A, B, and C inclusions is based on a log-log plot of the data in Table 1 on Minimum Values for Inclusion Rating Numbers (Methods A and D). Such plots¹⁰ reveal a linear relationship between the severity numbers and the minimum total sulfide length (Type A) and the minimum total stringer length (Types B & C) per 0.50-mm² field for each severity level as shown in Figs. 10-12. A least-square fit to the data in Table 1 has been used to produce the relationships in Table 6, which can be used to calculate the severity of Type A, B, and C inclusions, either thin or thick. The antilog is determined and rounded downward to the nearest half-severity value.

11.7 Calculation of the severity numbers for D-type oxides is done in the same manner as for Types A, B, and C inclusions except that the criterion is the number of oxides rather than their length. Fig. 13 shows a log-log plot of the data in Table 1.

11.8 The fields shown in Plate I-r represent the total lengths of the A inclusions, the total stringer lengths of B and C inclusions, the number of D inclusions, and their respective limiting widths or diameters. If any inclusions are present that are longer than the fields shown in Plate I-r, their lengths shall be recorded separately. If their widths or diameters are greater than the limiting values

¹⁰ Vander Voort, G. F., and Golden, J. F., "Automating the JK Inclusion Analysis," *Microstructural Science*, Vol 10, Elsevier Science Publishing Co., Inc., NY, 1982, pp. 277-290.

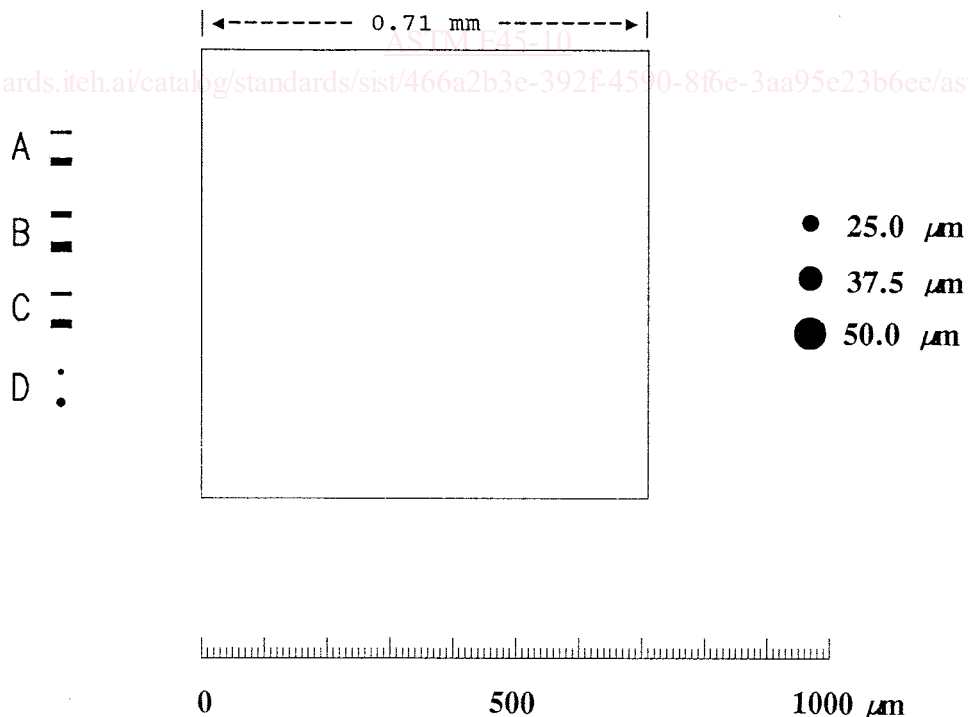

NOTE 1—The square mask will yield a field area of 0.50 mm² on the specimen surface. A graphic representation of the maximum thickness of the Thin and Heavy series of Types A, B, C, and D is on the left. Several oversized Type D are depicted on the right for convenience.

FIG. 5 Suggested Reticle or Overlay Grid For Methods A, D, and E

