

ISO/TC 281

Secretariat: JISC

Voting begins on:
2020-09-10

Voting terminates on:
2020-11-05

Fine bubble technology — Water treatment applications —

Part 1: Test method for evaluating ozone fine bubble water generating systems by the decolorization of methylene blue

iTeh STANDARD PREVIEW
(standards.iteh.ai)
Full standard:
<https://standards.iteh.ai/catalog/standards/sist/123304-1/iso-fdis-20304-1>
4714-83bb-c2b73a27dc1/iso-fdis-20304-1

RECIPIENTS OF THIS DRAFT ARE INVITED TO SUBMIT, WITH THEIR COMMENTS, NOTIFICATION OF ANY RELEVANT PATENT RIGHTS OF WHICH THEY ARE AWARE AND TO PROVIDE SUPPORTING DOCUMENTATION.

IN ADDITION TO THEIR EVALUATION AS BEING ACCEPTABLE FOR INDUSTRIAL, TECHNOLOGICAL, COMMERCIAL AND USER PURPOSES, DRAFT INTERNATIONAL STANDARDS MAY ON OCCASION HAVE TO BE CONSIDERED IN THE LIGHT OF THEIR POTENTIAL TO BECOME STANDARDS TO WHICH REFERENCE MAY BE MADE IN NATIONAL REGULATIONS.



Reference number
ISO/FDIS 20304-1:2020(E)

iTeh STANDARD PREVIEW
(standards.iteh.ai)
Full standard:
<https://standards.iteh.ai/catalog/standards/sist/12eb3dab-d0b5-4744-83bb-cf2b73a27dc1/iso-fdis-20304-1>



COPYRIGHT PROTECTED DOCUMENT

© ISO 2020

All rights reserved. Unless otherwise specified, or required in the context of its implementation, no part of this publication may be reproduced or utilized otherwise in any form or by any means, electronic or mechanical, including photocopying, or posting on the internet or an intranet, without prior written permission. Permission can be requested from either ISO at the address below or ISO's member body in the country of the requester.

ISO copyright office
CP 401 • Ch. de Blandonnet 8
CH-1214 Vernier, Geneva
Phone: +41 22 749 01 11
Email: copyright@iso.org
Website: www.iso.org

Published in Switzerland

Contents

	Page
Foreword.....	iv
Introduction.....	v
1 Scope.....	1
2 Normative references.....	1
3 Terms and definitions.....	1
4 Decolorization test by ozone fine bubble water.....	2
4.1 Principle.....	2
4.2 Test environment conditions.....	2
4.3 Configuration of test equipment.....	2
4.4 Raw material gas supply unit (A unit).....	3
4.5 Ozone generator supply unit (B unit).....	3
4.6 Chemical reaction unit by ozone (C unit).....	4
4.7 Discharged ozone treatment unit (D unit).....	5
4.8 Calibration procedure.....	5
4.9 Test procedure.....	5
5 Expression of test results of the decolorization effect.....	6
5.1 Evaluation object.....	6
5.2 Functional processing.....	6
5.3 Uncertainty evaluation.....	7
6 Measurement of size and number concentration classification using air.....	7
7 Test report.....	7
Annex A (informative) Examples of in-line measuring instruments.....	9
Annex B (informative) Example of test results for ozone bubble and ozone fine bubble water generating systems.....	11
Bibliography.....	13

Foreword

ISO (the International Organization for Standardization) is a worldwide federation of national standards bodies (ISO member bodies). The work of preparing International Standards is normally carried out through ISO technical committees. Each member body interested in a subject for which a technical committee has been established has the right to be represented on that committee. International organizations, governmental and non-governmental, in liaison with ISO, also take part in the work. ISO collaborates closely with the International Electrotechnical Commission (IEC) on all matters of electrotechnical standardization.

The procedures used to develop this document and those intended for its further maintenance are described in the ISO/IEC Directives, Part 1. In particular, the different approval criteria needed for the different types of ISO documents should be noted. This document was drafted in accordance with the editorial rules of the ISO/IEC Directives, Part 2 (see www.iso.org/directives).

Attention is drawn to the possibility that some of the elements of this document may be the subject of patent rights. ISO shall not be held responsible for identifying any or all such patent rights. Details of any patent rights identified during the development of the document will be in the Introduction and/or on the ISO list of patent declarations received (see www.iso.org/patents).

Any trade name used in this document is information given for the convenience of users and does not constitute an endorsement.

For an explanation of the voluntary nature of standards, the meaning of ISO specific terms and expressions related to conformity assessment, as well as information about ISO's adherence to the World Trade Organization (WTO) principles in the Technical Barriers to Trade (TBT), see www.iso.org/iso/foreword.html.

This document was prepared by Technical Committee ISO/TC 281, *Fine bubble technology*.

A list of all parts in the ISO 20304 series can be found on the ISO website.

Any feedback or questions on this document should be directed to the user's national standards body. A complete listing of these bodies can be found at www.iso.org/members.html.

Introduction

Ozone is used to improve water quality e.g. for purification and decomposition of hardly decomposable substances and decolorization. The conventional method often uses diffuser tubes. However, it has been found that with ozone fine bubbles, it is possible to use the strong oxidizing power of ozone more efficiently.

In recent years, the establishment of fine bubble generating technology has made ozone utilization efficiency higher than that of diffuser tube systems. Test results demonstrate that ozone fine bubble water generating systems are about 1,6 times more efficient than diffuser tube systems. With this efficiency increase, cost reduction has become possible.

Decolorization is mainly used for factory wastewater, regeneration and sewage water. It is also used on a regular basis for sewage treatment facilities, as advanced treatment technology in the dye-house effluent, etc.

iTeh STANDARD PREVIEW
(standards.iteh.ai)
Full standard:
<https://standards.iteh.ai/catalog/standards/sist/12eb3dab-d0b5-4744-83bb-cf2b73a27dc1/iso-fdis-20304-1>

iTeh STANDARD PREVIEW
(standards.iteh.ai)

Full standard:
<https://standards.iteh.ai/catalog/standards/sist/12eb3dab-d0b5-4744-83bb-cf2b73a27dc1/iso-fdis-20304-1>

Fine bubble technology — Water treatment applications —

Part 1:

Test method for evaluating ozone fine bubble water generating systems by the decolorization of methylene blue

WARNING — Persons using this document should be familiar with normal laboratory practice. This document does not purport to address all of the safety problems, if any, associated with its use. It is the responsibility of the user to establish appropriate safety and health practices and to determine the applicability of any other restrictions.

1 Scope

This document specifies a test method to assess the performance of ozone fine bubble water generating systems used for decolorizing water-soluble dye in e.g. wastewater and industrial water. This document does not address the impact of ozone on health and environment.

2 Normative references

The following documents are referred to in the text in such a way that some or all of their content constitutes requirements of this document. For dated references, only the edition cited applies. For undated references, the latest edition of the referenced document (including any amendments) applies.

ISO 10678, *Fine ceramics (advanced ceramics, advanced technical ceramics) — Determination of photocatalytic activity of surfaces in an aqueous medium by degradation of methylene blue*

ISO 20480-1, *Fine bubble technology — General principles for usage and measurement of fine bubbles — Part 1: Terminology*

ISO 20480-2:2018, *Fine bubble technology — General principles for usage and measurement of fine bubbles — Part 2: Categorization of the attributes of fine bubbles*

3 Terms and definitions

For the purposes of this document, the terms and definitions given in ISO 20480-1 and the following apply.

ISO and IEC maintain terminological databases for use in standardization at the following addresses:

- ISO Online browsing platform: available at <https://www.iso.org/obp>
- IEC Electropedia: available at <http://www.electropedia.org/>

3.1

fine bubble water

water containing air fine bubbles

3.2

ozone fine bubble water

water containing ozone fine bubbles

3.3

absorbance

natural logarithm of the ratio of the light amount before and after transmission of the test water-soluble dye with the photometric amount defined in ISO 80000-7:2019, 7-32.1

3.4

half-life of absorbance

time required for the change in absorbance to reach 50 % of the initial concentration

4 Decolorization test by ozone fine bubble water

4.1 Principle

A measured quantity of ozone is sent to a water-soluble dye tank through a fine bubble water generating system. The absorbance in the tank is optically measured to determine the half-life of absorbance. Absorbance is measured using e.g. a colorimeter, spectrophotometer or absorbance meter. It is desirable to use an inline type absorbance measuring instrument. Examples of inline measuring instruments are shown in [Annex A](#).

4.2 Test environment conditions

The temperature of the test room should be $23\text{ °C} \pm 3\text{ °C}$ and the relative humidity should be $50\% \pm 10\%$. In addition, it should be taken care not to mix fine particles in the test environment.

4.3 Configuration of test equipment

The testing apparatus comprises a raw material gas supply unit, an ozone generator supply unit, a chemical reaction unit by ozone, and a discharged ozone treatment unit. The configuration of the test equipment is shown in [Figure 1](#). The ozone reaction unit is indicated by a double line in [Figure 1](#).

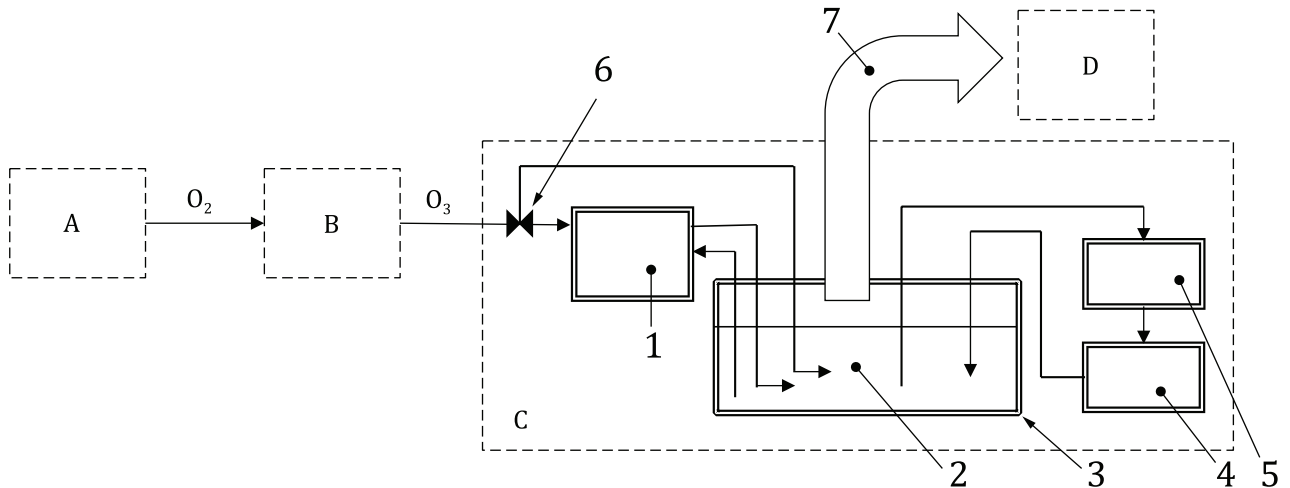
**Key**

- 1 fine bubble water generating system
- 2 fine bubble water with dissolved methylene blue
- 3 test tank
- 4 circulating pump
- 5 measurement instrument unit
- 6 valve
- 7 untreated O₃
- A raw material gas supply unit
- B ozone generator supply unit
- C chemical reaction unit by ozone
- D discharged ozone treatment unit

Figure 1 — Configuration of test equipment

4.4 Raw material gas supply unit (A unit)

The raw material gas supply unit (A unit) is shown in [Figure 1](#). [Figure 1](#) shows a material gas supply unit when using an oxygen cylinder or an oxygen gas generator. The oxygen concentration of the material gas supply should be 90 % or more.

4.5 Ozone generator supply unit (B unit)

The conditions for supply of ozone to the ozone reaction unit shall be as follows:

- a) The ozone flow rate shall be 0,5 l/min, the ozone yield shall be 3 g/h, it is important that the gas gauge pressure is set and maintained at a certain level of pressure. In addition, the numerical value of the gas gauge pressure shall be given in the test report, see [Clause 7](#).

NOTE The conversion between ozone mass concentration and volume fraction is standardized by ISO 13964:1998, 7.2. The results are reported as micrograms per cubic meter at the chosen reference conditions, or as volume fraction. For ozone, a volume fraction of $1,0 \times 10^{-6}$ at 0 °C, 101,3 kPa (standard condition) is equivalent to 2 141 µg/m³ and 1 995 µg/m³ at 20 °C, 101,3 kPa.

- b) The ozone generator supply unit (B unit) is shown in [Figure 1](#).

4.6 Chemical reaction unit by ozone (C unit)

This C unit is composed of a fine bubble water generating system, a test tank, a measuring instrument and a circulating pump. The installation of fine bubble water generating system shall be structured so that the reference water-soluble dye in the test tank does not leak out of the system in case of immersion.

a) The fine bubble water generating system is as follows.

- 1) The equipment has the function to discharge fine bubble water and to circulate it. A material that can withstand the oxidizing power of ozone shall be used.
- 2) The operation conditions and data of fine bubble water generating system should be provided by the system supplier.
- 3) [Figure 1](#) shows the chemical reaction unit (C unit) using the fine bubble water generating system which includes the configuration of the reaction apparatus and dissolution apparatus of the ozone reaction section.

b) Test tank

It is an aquarium that can be hermetically sealed so as not to leak ozone. It is made of a material that can withstand the oxidizing power of ozone. A colourless and transparent column is desirable to carry out the test while observing the change in colour. The column should have such an enough capacity that can reserve the ozone fine bubble water when it is generated. The reference test tank is made of glass with a capacity of 60 l or more, and the water depth at the time of test shall be $35 \text{ cm} \pm 1 \text{ cm}$.

The bottom area and the water surface area of the test tank should be equal.

Validation or calibration of measuring equipment shall be as follows:

- 1) Ozone concentration meter, see ISO 1431-3;
- 2) Photometric instrument, calibration and measurement confirmation of inline type measuring instrument using a standard solution;
- 3) pH meter, adjusted with standard calibration solution.

c) Water

The water quality shall be determined in accordance with ISO 20480-2:2018, 4.2.

d) Methylene blue

Methylene blue powder specified in ISO 10678 shall be used.

NOTE The maximum absorption wavelength is 664 nm.

e) Methylene blue standard stock solution

Weigh 0,15 g of methylene blue powder and dissolve in 1 l of water.

f) Test coloured water

Prepare the test coloured water using 1 l of methylene blue stock solution, adjusted to 60 l. The pH of the test coloured water shall be $8 > \text{pH} > 5$. At the start of the test, it is recommended to set the water temperature to $20 \text{ }^\circ\text{C} \pm 2 \text{ }^\circ\text{C}$ and neutral range of pH.

g) Circulating pump for absorbance measurement