

---

---

**Safety of toys —**

Part 1:

**Safety aspects related to mechanical  
and physical properties**

**AMENDMENT 2: Various**

**iTeh STANDARD PREVIEW**

*Sécurité des jouets —*

**(standards.iteh.ai)**

*Partie 1: Aspects de sécurité relatifs aux propriétés mécaniques et  
physiques*

*ISO 8124-1:2018/Amd.2:2020*

**AMENDEMENT 2: Divers**

<https://standards.iteh.ai/catalog/standards/sist/710a9a63-cef7-44f1-a80d-e3f8b3c73d7e/iso-8124-1-2018-amd-2-2020>



## iTeh STANDARD PREVIEW (standards.iteh.ai)

<https://standards.iteh.ai/catalog/standards/sist/710a9a63-cef7-44fl-a80d-e3f8b3c73d7e/iso-8124-1-2018-amd-2-2020>



### **COPYRIGHT PROTECTED DOCUMENT**

© ISO 2020

All rights reserved. Unless otherwise specified, or required in the context of its implementation, no part of this publication may be reproduced or utilized otherwise in any form or by any means, electronic or mechanical, including photocopying, or posting on the internet or an intranet, without prior written permission. Permission can be requested from either ISO at the address below or ISO's member body in the country of the requester.

ISO copyright office  
CP 401 • Ch. de Blandonnet 8  
CH-1214 Vernier, Geneva  
Phone: +41 22 749 01 11  
Fax: +41 22 749 09 47  
Email: [copyright@iso.org](mailto:copyright@iso.org)  
Website: [www.iso.org](http://www.iso.org)

Published in Switzerland

## Foreword

ISO (the International Organization for Standardization) is a worldwide federation of national standards bodies (ISO member bodies). The work of preparing International Standards is normally carried out through ISO technical committees. Each member body interested in a subject for which a technical committee has been established has the right to be represented on that committee. International organizations, governmental and non-governmental, in liaison with ISO, also take part in the work. ISO collaborates closely with the International Electrotechnical Commission (IEC) on all matters of electrotechnical standardization.

The procedures used to develop this document and those intended for its further maintenance are described in the ISO/IEC Directives, Part 1. In particular, the different approval criteria needed for the different types of ISO documents should be noted. This document was drafted in accordance with the editorial rules of the ISO/IEC Directives, Part 2 (see [www.iso.org/directives](http://www.iso.org/directives)).

Attention is drawn to the possibility that some of the elements of this document may be the subject of patent rights. ISO shall not be held responsible for identifying any or all such patent rights. Details of any patent rights identified during the development of the document will be in the Introduction and/or on the ISO list of patent declarations received (see [www.iso.org/patents](http://www.iso.org/patents)).

Any trade name used in this document is information given for the convenience of users and does not constitute an endorsement.

For an explanation of the voluntary nature of standards, the meaning of ISO specific terms and expressions related to conformity assessment, as well as information about ISO's adherence to the World Trade Organization (WTO) principles in the Technical Barriers to Trade (TBT) see [www.iso.org/iso/foreword.html](http://www.iso.org/iso/foreword.html).

This document was prepared by Technical Committee ISO/TC 181, *Safety of toys*.

A list of all parts in the ISO 8124 series can be found on the ISO website.

Any feedback or questions on this document should be directed to the user's national standards body. A complete listing of these bodies can be found at [www.iso.org/members.html](http://www.iso.org/members.html).

**iTeh STANDARD PREVIEW**  
**(standards.iteh.ai)**

ISO 8124-1:2018/Amd 2:2020

<https://standards.iteh.ai/catalog/standards/sist/710a9a63-cef7-44f1-a80d-e3f8b3c73d7e/iso-8124-1-2018-amd-2-2020>

# Safety of toys —

## Part 1:

# Safety aspects related to mechanical and physical properties

## AMENDMENT 2: Various

Add the following new terminological entry:

### 3.88

#### toy bag

bag, clearly intended for use in play, often having features designed to encourage children to use it in play activities

Note 1 to entry: Bags that are used solely for storage of the toy or its components are to be considered packaging regardless of whether they are attractive to children, for example if they are brightly coloured or have characteristics appealing to children. Such characteristics alone are not enough to define them as toy bags.

(standards.iteh.ai)

Replace the existing 4.3.2 with the following:

[ISO 8124-1:2018/Amd 2:2020](https://standards.iteh.ai/catalog/standards/sist/710a9a63-cef7-44f1-a80d-e3f8b3c73d7e/iso-8124-1-2018-amd-2-2020)

**4.3.2 Expanding materials** [standards.iteh.ai/catalog/standards/sist/710a9a63-cef7-44f1-a80d-e3f8b3c73d7e/iso-8124-1-2018-amd-2-2020](https://standards.iteh.ai/catalog/standards/sist/710a9a63-cef7-44f1-a80d-e3f8b3c73d7e/iso-8124-1-2018-amd-2-2020)

See E.5.

Toys and components of toys which are *expanding materials* and fit entirely, whatever their orientation, into the small parts cylinder (see Figure 26) shall completely pass through the gauge specified in Figure X1, if required when tested in accordance with 5.21 (expanding materials). For a toy or component that at time of purchase is in an expanded state, the small part size assessment shall be performed when it is in a shrunken state.

This requirement does not apply to seeds in growing kits. The requirements in this subclause are not applicable after testing in accordance with 5.24 (reasonably foreseeable abuse tests).

Replace the existing 4.5.1.1 with the following:

#### 4.5.1.1 General

The requirements of 4.5.1 (squeeze toys, rattles, fasteners and certain other toys and components of toys) do not apply to:

- soft-filled (stuffed) toys or soft-filled parts of toys or parts made entirely of fabric; or
- rigid elements having a major dimension equal to 30 mm or less.

Delete the last paragraph of 4.8.1:

Toys intended to be repeatedly assembled and taken apart shall have the individual pieces and fully assembled articles, as shown on packaging graphics, instructions, or other advertising, evaluated

separately. The requirements for the assembled toy do not apply to toys for which the assembling makes up a significant part of the play value of the toy.

*Modify 4.11.3.2 as follows:*

Where other cords are included with or attached to toys (excluding pull toys) with a free length exceeding 300 mm, when measured according to 5.11.2 (length of cords and electrical cables), the toy's packaging shall carry a warning indicating that the toy is unsuitable for children under the age of 18 months (see B.2.23, toys with cords intended for children 18 months and over but under 36 months). This requirement applies to any cords remaining attached to toys after assessment against 4.11.3.1 b).

*Modify 4.11.3.3 as follows:*

Where other cords without a free end, with a length exceeding 220 mm but not exceeding 300 mm when measured according to 5.11.2 (length of cords and electrical cables), are included with or attached to toys, the toy's packaging shall carry a warning indicating that the toy is not suitable for children under the age of 18 months (see B.2.23, toys with cords intended for children 18 months and over but under 36 months).

*Replace 4.12.2 a) and b) with the following:*

- iTeh STANDARD PREVIEW**  
(standards.iteh.ai)
- a) have a safety stop or locking device to prevent unexpected or sudden movement or collapse of the toy. The safety stop or locking device shall not become partially or fully disengaged when tested in accordance with 5.24 (reasonably foreseeable abuse tests) and the toy shall not collapse when tested in accordance with 5.22.3 (other toys with folding mechanisms);
- or
- b) have adequate clearance between moving parts to protect the fingers and toes against crushing or laceration in the event of sudden movement or collapse of the toy. If it is possible to insert a 5 mm diameter rod between moving parts, it shall also be possible to insert a 12 mm diameter rod.

*Modify 4.18.3 b) as follows:*

- b) Projectiles with a kinetic energy greater than 0,08 J when tested according to 5.15.1 (kinetic energy of projectiles) shall:
- have a contact surface(s) made of a resilient material;
  - be accompanied by instructions for use that give the user information on how to use the toy safely (see B.2.15, projectile toys, for guidance). This requirement only applies to projectiles that it might reasonably be possible to aim at the face (see E.32, projectile toys); and
  - have a kinetic energy per unit area not greater than 2 500 J/m<sup>2</sup> when tested according to 5.15.1.3.3 (determination of kinetic energy per area of contact).

*Modify 4.18.4 as follows:*

Projectile toys without stored energy that could be launched at the face should be accompanied by instructions for use that give the user information on how to use the toy safely (see B.2.15, projectile toys). This recommendation does not apply to projectile toys intended to be thrown towards people, for example flying discs, balls or similar objects.

*Add the following new subclause:*

## **4.36 Assembly**

### **4.36.1 General**

Toys intended to be assembled shall be accompanied by assembly instructions with sufficient detail to ensure that the toy is assembled as intended by the manufacturer.

### **4.36.2 Toys intended to be assembled by a child**

If a toy is intended to be assembled by a child, the requirements in this document apply to each component made available to the child and to the assembled toy.

Toys, such as construction sets, where assembling provides a significant part of the play value of the toy shall be evaluated to determine if any potential hazards exist (e.g. projection hazards, projectile hazards, strangulation hazards). The evaluation is limited to those assemblies depicted on the packaging and/or instructions for use. Based on this evaluation, assemblies that have the potential to be hazardous shall be constructed and tested according to the appropriate subclauses of this document. For example, a toy that requires the child to assemble a working catapult shall be evaluated for any potential projectile hazards. Where a large number of assembly configurations are possible, the tests in 5.24 (reasonably foreseeable abuse tests) do not need to be carried out on the assembled toy.

NOTE It might only be necessary to construct a portion of the entire assembly to carry out the necessary testing.

### **4.36.3 Toys intended to be assembled by an adult**

If a toy is intended to be assembled by an adult, the requirements in this document apply only to the assembled toy.

Toys intended to be assembled by an adult shall:

- have packaging and instructions that prominently indicate that the article is to be assembled by an adult;
- have assembly instructions that highlight any connections that are important for the safe use of the toy, for example connections that prevent failures that may be, or cause, hazards;
- have instructions that include information on the potential hazards resulting from incorrect assembly if this could reasonably result in the creation of a hazard.

### **4.36.4 Toys that are intended to be disassembled between uses**

- The assembly instructions shall highlight the importance of keeping the instructions for future reference.
- Any connections that are important for the safe use of the toy shall be marked to indicate that the product must not be used without the connection in place.

*Delete the ninth paragraph of 5.1:*

Toys reasonably intended to be assembled by an adult and not intended to be taken apart by a child shall be tested only in the assembled state if the packaging and the assembly instructions prominently indicate that the article is to be assembled only by an adult.

*Replace the existing 5.21 with the following:*

See 4.3.2 (expanding materials).

Test the toy or component in accordance with points 1 to 4 below and determine whether it expands according to points 5 and 6. Toys or components that expand more than 50 % are tested according to points 7 and 8.

- 1) Condition the toy or component at  $(20 \pm 5)$  °C and at a relative humidity of 40 % to 65 % for a minimum of 7 h prior to the test.
- 2) Measure and record all dimensions of the toy or component, using calipers or another suitable measurement tool, to the nearest 0,1 mm; these dimensions represent the “as-received” state.
- 3) Submerge the toy or component under test in a bath of deionized water maintained at  $(37 \pm 2)$  °C for the duration of immersion, without agitation. For toys or components that exhibit positive buoyancy, place weight(s) (with mass just sufficient to achieve complete submersion) atop the toys or components. Care should be taken to minimize contact of the test toy or component with the sides or bottom of the container.
- 4) Maintain submersion for 72 h, measuring the sample dimensions as in point 2 at 6 h, 24 h, 48 h and 72 h durations.
- 5) If the toy or component exhibits expansion greater than 50 % in any dimension from its as-received state (see point 2) at any time interval, the toy or component shall be tested according to points 7 and 8.
- 6) If the toy or component exhibits expansion less than or equal to 50 % in all dimensions from its as-received state (see point 2) at all measurement time intervals, the toy or component shall be considered to meet the requirements of 4.3.2 (expanding materials) and no further testing according to 5.21 is required.
- 7) If the greatest expansion was observed at 72 h of immersion, proceed to immediately test the toy or component according to point 8. If the greatest expansion was observed at another time interval, condition a new sample according to point 1 and submerge this new sample according to point 3 for the time interval at which the greatest expansion was observed, then immediately test the toy or component according to point 8 at the conclusion of that interval.
- 8) While the toy or component is submerged in deionized water at  $(37 \pm 2)$  °C, attempt to push the object through the gauge pictured in Figure X1 (starting from the radiused side) with a force perpendicular to the flat surface of the gauge of up to 20 N using a 10 mm diameter rod with a hemispherical end, with the rod roughly centred within the hole in the gauge. Position the toy or component in the orientation least likely to pass through the gauge opening. The gauge shall be constructed of polytetrafluoroethylene (PTFE).



Dimensions in millimetres

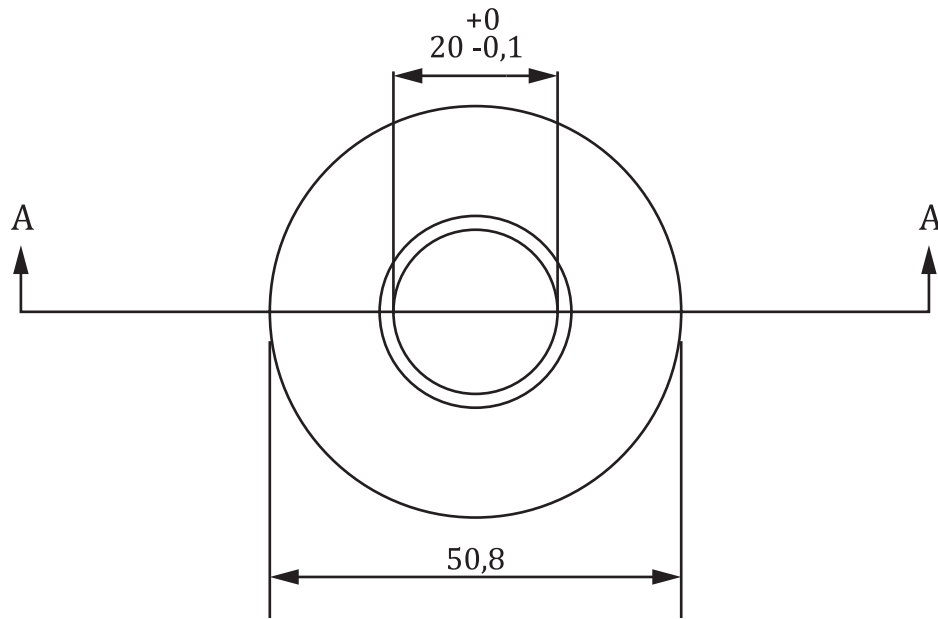

iTeh STANDARD PREVIEW

(standards.iteh.ai)

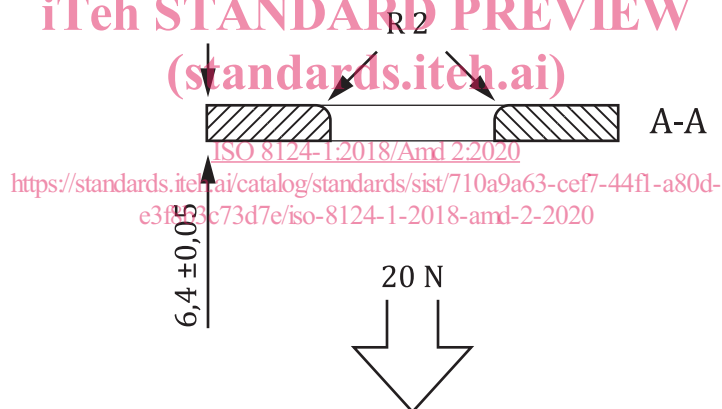

Figure X1 — Expanding toy test template

Modify the second paragraph of 5.24.2 as follows:

The impact surface shall consist of vinyl composition tiles of approximately 3 mm nominal thickness laid over concrete of at least 64 mm thickness. The impact surface shall be at least 0,3 m<sup>2</sup>.

Replace 5.24.6.1 with the following:

Any toy with a projection, part or assembly that a child can grasp with at least the thumb and forefinger or the teeth shall be subjected to this test. The tension test shall be performed on the same components of the toy subjected to the test in 5.24.5 (torque test).

If the component to be tested cannot be gripped between the thumb and forefinger, establish whether it is grippable by inserting the feeler gauge (see Figure X4) between the component and the underlying layer or body of the toy at an angle of between 0° and 10° from the toy surface using a force of (10 ± 1) N. If the gauge can be inserted more than 2 mm, the component shall be considered as grippable.