**Adhesives — Determination of shear
behaviour of structural adhesives —**

**Part 2:
Tensile test method using thick
adherends**

*Adhésifs — Détermination du comportement en cisaillement
d'adhésifs structuraux —*

Partie 2: Méthode d'essai en traction sur éprouvette épaisse

Document Preview

ISO 11003-2:2019

<https://standards.iteh.ai/catalog/standards/iso/999d7b00-54c8-4f30-9806-454eb58e9497/iso-11003-2-2019>



iTeh Standards
(<https://standards.iteh.ai>)
Document Preview

[ISO 11003-2:2019](https://standards.iteh.ai/catalog/standards/iso/999d7b00-54c8-4f30-9806-454eb58e9497/iso-11003-2-2019)

<https://standards.iteh.ai/catalog/standards/iso/999d7b00-54c8-4f30-9806-454eb58e9497/iso-11003-2-2019>



COPYRIGHT PROTECTED DOCUMENT

© ISO 2019

All rights reserved. Unless otherwise specified, or required in the context of its implementation, no part of this publication may be reproduced or utilized otherwise in any form or by any means, electronic or mechanical, including photocopying, or posting on the internet or an intranet, without prior written permission. Permission can be requested from either ISO at the address below or ISO's member body in the country of the requester.

ISO copyright office
CP 401 • Ch. de Blandonnet 8
CH-1214 Vernier, Geneva
Phone: +41 22 749 01 11
Fax: +41 22 749 09 47
Email: copyright@iso.org
Website: www.iso.org

Published in Switzerland

Contents

Page

Foreword	iv
1 Scope	1
2 Normative references	1
3 Terms and definitions	1
4 Principle	2
5 Apparatus	3
6 Specimen	3
6.1 Specimen dimensions and configuration	3
6.2 Adherends	4
6.3 Preparation of surfaces before bonding	4
7 Test specimen	5
7.1 Preparation	5
7.1.1 Specimens with flat-ended adherends	5
7.1.2 Specimens with stepped adherends	6
7.2 Number of specimens	6
8 Procedure	8
9 Calculations	10
9.1 Symbols used	10
9.2 Average shear stress τ in the adhesive	10
9.3 Shear strain γ in the adhesive	10
9.4 Stress strain curve	12
9.5 Shear modulus of the adhesive	12
10 Precision	12
11 Test report	12
Annex A (informative) Suitable extensometer design	14

Foreword

ISO (the International Organization for Standardization) is a worldwide federation of national standards bodies (ISO member bodies). The work of preparing International Standards is normally carried out through ISO technical committees. Each member body interested in a subject for which a technical committee has been established has the right to be represented on that committee. International organizations, governmental and non-governmental, in liaison with ISO, also take part in the work. ISO collaborates closely with the International Electrotechnical Commission (IEC) on all matters of electrotechnical standardization.

The procedures used to develop this document and those intended for its further maintenance are described in the ISO/IEC Directives, Part 1. In particular, the different approval criteria needed for the different types of ISO documents should be noted. This document was drafted in accordance with the editorial rules of the ISO/IEC Directives, Part 2 (see www.iso.org/directives).

Attention is drawn to the possibility that some of the elements of this document may be the subject of patent rights. ISO shall not be held responsible for identifying any or all such patent rights. Details of any patent rights identified during the development of the document will be in the Introduction and/or on the ISO list of patent declarations received (see www.iso.org/patents).

Any trade name used in this document is information given for the convenience of users and does not constitute an endorsement.

For an explanation of the voluntary nature of standards, the meaning of ISO specific terms and expressions related to conformity assessment, as well as information about ISO's adherence to the World Trade Organization (WTO) principles in the Technical Barriers to Trade (TBT) see www.iso.org/iso/foreword.html.

This document was prepared by Technical Committee ISO/TC 61, *Plastics*, Subcommittee SC 11, *Products*.

This third edition cancels and replaces the second edition (ISO 11003-2:2001), which has been technically revised. The main changes compared to the previous edition are as follows:

- the scope now specifies that this document does not apply in case of adhesion failure;
- revision of former subclause 8.3 (now [9.3](#)), "Shear strain γ in the adhesive".

A list of all parts in the ISO 11003 series can be found on the ISO website.

Any feedback or questions on this document should be directed to the user's national standards body. A complete listing of these bodies can be found at www.iso.org/members.html.

Adhesives — Determination of shear behaviour of structural adhesives —

Part 2: Tensile test method using thick adherends

1 Scope

This document specifies a test method for determining the shear behaviour of an adhesive in a single lap joint bonded assembly when subjected to a tensile force.

The test is performed on specimens consisting of thick, rigid adherends, with a short length of overlap, in order to obtain the most uniform distribution of shear stresses possible and to minimize other stress states which initiate failure.

This test method may be used to determine:

- the shear-stress against shear-strain curve to failure of the adhesive;
- the shear modulus of the adhesive;
- other adhesive properties that can be derived from the stress/strain curve such as secant shear modulus and maximum shear stress;
- the effect of temperature, environment, test speed, etc., on these properties.

This document does not apply in case of adhesion failure.

2 Normative references

The following documents are referred to in the text in such a way that some or all of their content constitutes requirements of this document. For dated references, only the edition cited applies. For undated references, the latest edition of the referenced document (including any amendments) applies.

ISO 291, *Plastics — Standard atmospheres for conditioning and testing*

ISO 683-3, *Heat-treatable steels, alloy steels and free-cutting steels — Part 3: Case-hardening steels*

ISO 14737, *Carbon and low alloy cast steels for general applications*

ISO 17212, *Structural adhesives — Guidelines for the surface preparation of metals and plastics prior to adhesive bonding*

ISO 4995, *Hot-rolled steel sheet of structural quality*

ISO 10365, *Adhesives — Designation of main failure patterns*

3 Terms and definitions

No terms and definitions are listed in this document.

ISO and IEC maintain terminological databases for use in standardization at the following addresses:

- ISO Online browsing platform: available at <https://www.iso.org/obp>

— IEC Electropedia: available at <http://www.electropedia.org/>

4 Principle

An adhesively bonded test specimen (see [Figure 1](#)) is subjected to a tensile force so that the adhesive is stressed in shear.

The relative displacement of the adherends is measured using a purpose-built transducer located in the central region of the specimen. Force and displacement are measured from the start of application of the load until fracture of the specimen. The shear stresses and strains are then calculated from the bond dimensions.

Dimensions in millimetres

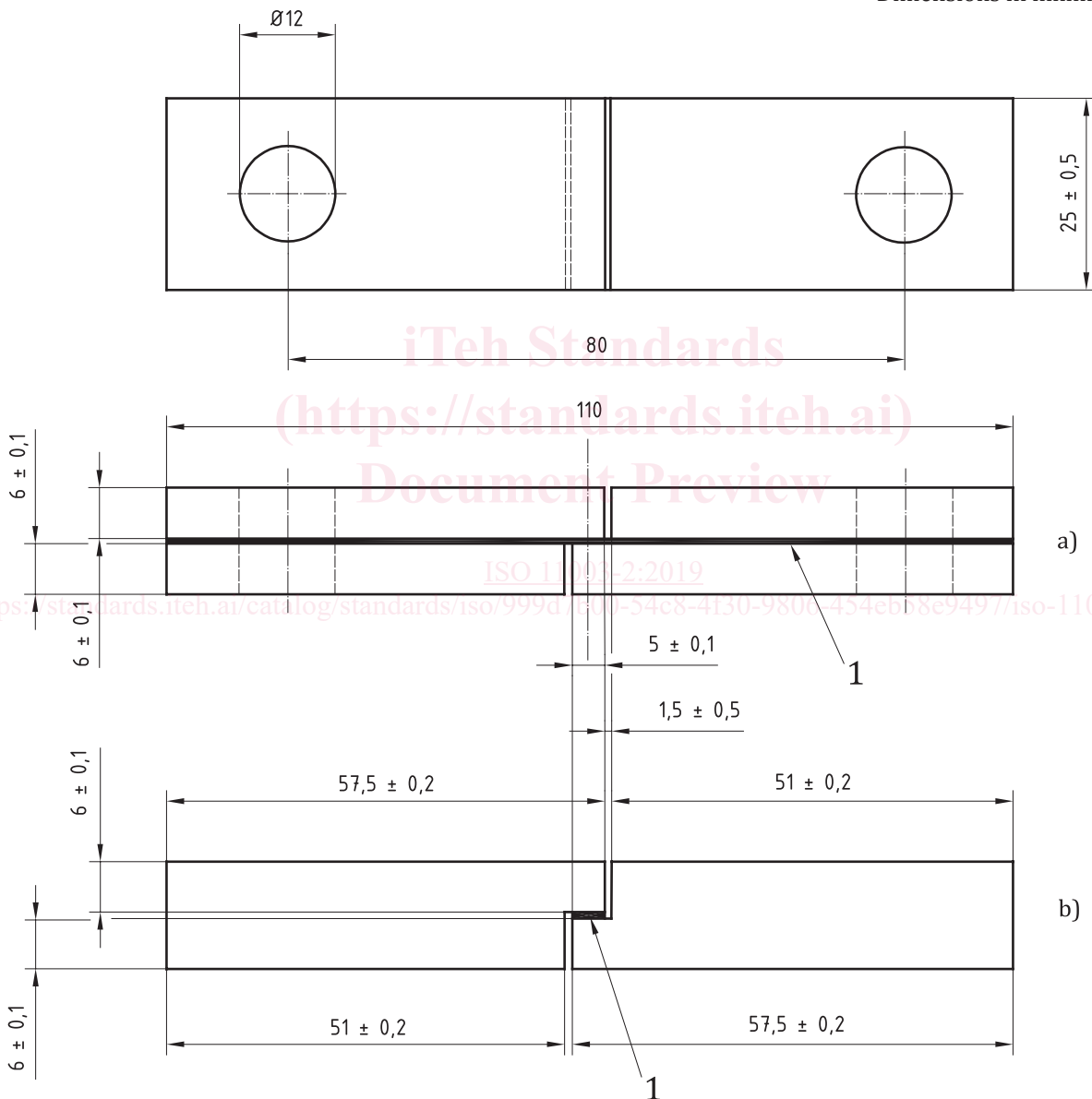

Key

- 1 adhesive bond
- a) bonded adherends
- b) machined adherends

Figure 1 — Specimen dimensions and configuration

5 Apparatus

5.1 Tensile-testing machine, capable of producing fracture in the specimen at a tensile force between 10 % and 80 % of the full-scale range of the force transducer.

5.2 Device for introducing a force into the specimen, so that negligible torque develops when force is applied to the specimen. For this purpose, the simple universal-joint design shown in [Figure 2](#) is satisfactory.

5.3 Force transducer, capable of measuring the force in the specimen with an accuracy of 1 % of the force at a shear strain of 0,01.

5.4 One or two extensometers (see note), for measuring the shear displacement between points of known separation on each adherend in the central region of the bond (see [Figure 3](#) and [Annex A](#)). The points of contact with the adherends shall be within a distance of 2 mm from the bonded faces. The device(s) shall be capable of measuring the shear displacement to an accuracy of 1 μm .

During loading, each adherend will bend slightly, leading to a small rotation of the central (bonded) region of the test specimen. In order to achieve high accuracy in displacement measurements, it is necessary for the extensometer(s) to rotate with the specimen. This has been achieved in the design shown in [Figure 3](#) by double-pin contact with one of the adherends.

NOTE The use of two extensometers on opposing faces of the specimen is recommended to minimize, by averaging the extensometer readings, any contribution to measurements from a twisting moment applied to the specimen. The use of two extensometers will also serve to indicate any malfunctioning of one of the extensometers as revealed by significantly different readings from the two devices.

5.5 Data-logging equipment, to continuously record the relative displacement of the adherends and the applied load, from the start of application of the load until the specimen breaks.

5.6 Micrometer, having an accuracy of better than 0,002 mm, to measure the dimensions of the adherends.

5.7 Optical microscope, having an accuracy of better than 0,002 mm, to measure the thickness of the adhesive bond when the specimen configuration shown in [Figure 1 a\)](#) is used.

6 Specimen

6.1 Specimen dimensions and configuration

Specimens shall be prepared either by bonding metal plates or strips together to produce the configuration shown in [Figure 1 a\)](#) or by bonding adherends that have been machined to the shape shown in [Figure 1 b\)](#). The dimensions of the specimen are given in [Figure 1](#) and are the same, within variations in the bond thickness, for both preparation methods.

The bond thickness shall lie in the range 0,2 mm to 0,8 mm.

NOTE 1 The preferred bond thickness is 0,5 mm.

NOTE 2 The adherends shown in [Figure 1 a\)](#) have a lower bending stiffness than the continuous geometry shown in [Figure 1 b\)](#). Consequently, the peel stresses at the ends of the adhesive in the specimen in [Figure 1 a\)](#) will be higher than those in the specimen in [Figure 1 b\)](#). It has small influence on stress and strain measurement but, since failure is generally initiated by these peel stresses, the specimen design shown in [Figure 1 a\)](#) is likely to fail earlier (at lower stress and strain) than the design shown in [Figure 1 b\)](#).

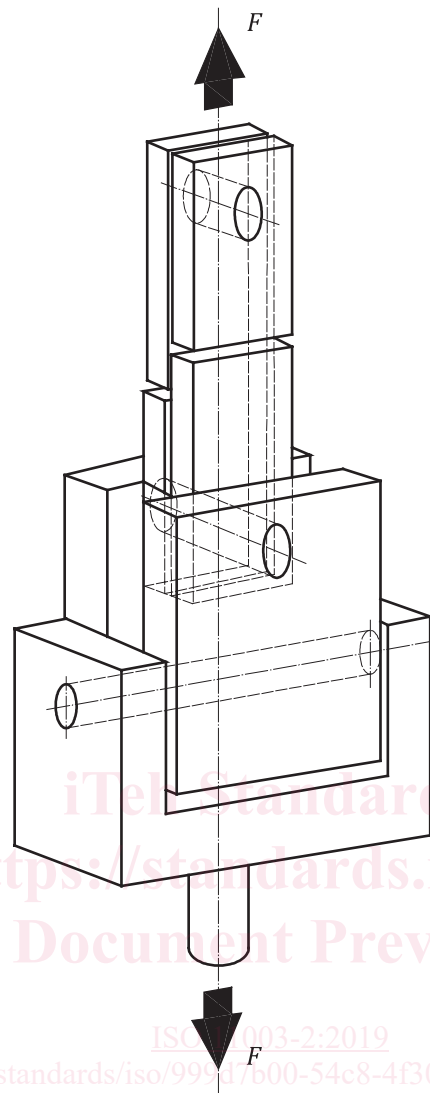

Figure 2 — Example of device for loading the specimen in a tensile-testing machine

6.2 Adherends

For the purpose of the measurement of the properties of the adhesive, steel adherends are recommended because of their high modulus.

NOTE A suitable steel is XC18 or E24, Grade 1 or 2.

Machine the panels or bars to be used for the adherends in accordance with ISO 683-3, ISO 14737 and ISO 4995 to the dimensions given in [Figures 1 a\)](#) or [Figure 1 b\)](#) depending on which specimen configuration is chosen.

6.3 Preparation of surfaces before bonding

The surfaces to be bonded shall be prepared in accordance with ISO 17212 or by any other method leading to cohesive failure within the adhesive layer.

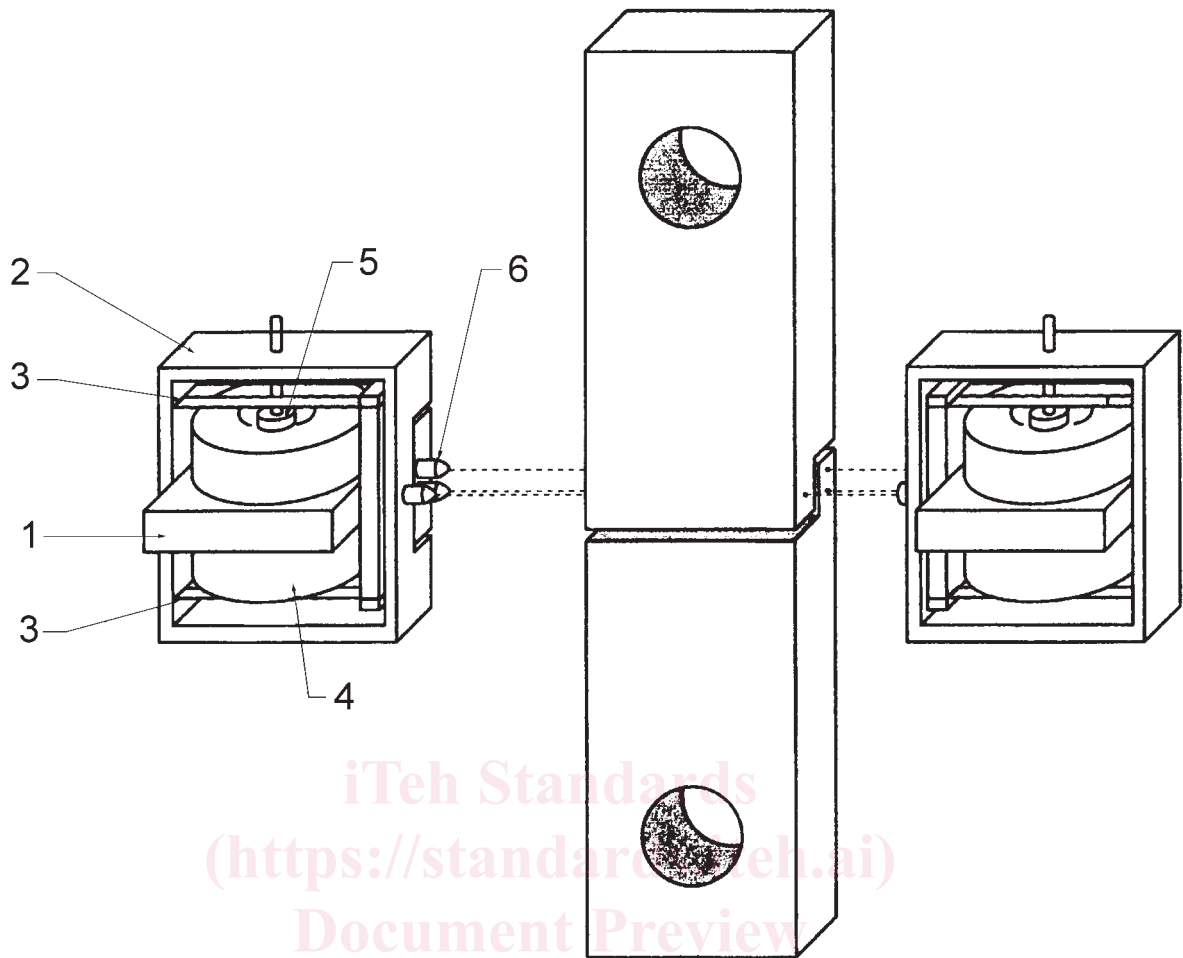

Key

- 1 mobile inner part
- 2 rigid outer frame
- 3 steel leaf spring
- 4 transducer coil
- 5 transducer core
- 6 tungsten pins

Figure 3 — Example of extensometer positioning

7 Test specimen

7.1 Preparation

7.1.1 Specimens with flat-ended adherends

7.1.1.1 General

Specimens with flat-ended adherends shall have the configuration shown in [Figure 1 a\)](#) and may be prepared from uncut panels, from pre-cut panels or as individual specimens from machined plates.

7.1.1.2 Uncut panels

The panels from which the specimens are cut shall consist of two sheets with dimensions in accordance with [Figure 4](#), bonded together in accordance with the adhesive manufacturer's instructions.

In order to define the thickness of the adhesive, shims or spacers (metal foil) or calibrated metal wires may be incorporated outside the area which will become the overlap zone.

Cut the bonded panels into specimens using a suitable tool such as a band saw. Then subject the specimens to the required machining. Perform the last pass on the edge of the specimen parallel to the longitudinal direction of the specimen to avoid any metal burrs along the bonded joint.

Drill holes at the ends of each specimen for pins to hold the specimen to the tensile-testing machine.

Delineate the overlap zone by milling two grooves as shown in [Figure 5](#).

When the specimens are machined, care shall be taken to ensure that the assembly is not heated above 50 °C. No liquid shall be used for cooling.

7.1.1.3 Pre-cut panels

Proceed as in [7.1.1.2](#), using two pre-cut sheets so as to obtain a panel in accordance with [Figure 6](#).

Two holes shall be provided in each sheet so that the two sheets can be superposed correctly using an assembly with two centering lugs.

Cut out and machine specimens as explained in [7.1.1.2](#).

7.1.1.4 Individual specimens

Bond two plates of dimensions 110 mm × 25 mm × 6 mm in accordance with the adhesive manufacturer's instructions, defining the thickness of the adhesive joint as indicated in [7.1.1.2](#). Ensure that the sides of the adherends are parallel to the nearest 0,1 mm.

Machine each specimen to the required size.

<https://standards.iteh.ai/catalog/standards/iso/999d7b00-54c8-4f30-9806-454eb58e9497/iso-11003-2-2019>

Drill holes for applying the load.

Make two grooves by milling to delineate the overlap.

Take the same precautions as in [7.1.1.2](#).

7.1.2 Specimens with stepped adherends

The adherends for this specimen type shall be machined to the dimensions given in [Figure 1 b\)](#) prior to bonding. The adherends shall be bonded whilst held securely in a frame that ensures accurate alignment of the adherends.

In order to produce a bond of well-defined shape and length, strips of steel or PTFE of thickness 1,5 mm shall be inserted in the gaps between the adherends after the application of the adhesive and prior to curing. They shall be removed after the adhesive has cured. If steel strips are used, they shall be coated with a release agent.

It is recommended that such strips have a 45° tapered edge so that a triangular fillet is formed at the end of the bond. This fillet reduces the strain concentration at the end of the bond which can extend the life of the test specimen.

7.2 Number of specimens

At least five specimens shall be tested for a given adhesive.