

DRAFT INTERNATIONAL STANDARD

ISO/DIS 17279-3

ISO/TC 44/SC 10

Secretariat: DIN

Voting begins on:
2020-02-19

Voting terminates on:
2020-05-13

Welding — Micro joining of 2nd generation high temperature superconductors —

Part 3: Test methods for joints

Soudage — Micro-assemblage des supraconducteurs à haute température critique de deuxième génération —

Partie 3: Méthode d'essai des connexions

ICS: 25.160.01

iTeh STANDARD PREVIEW
(standards.iteh.ai)
Full standard:
<https://standards.iteh.ai/catalog/standards/sist/67a9a027-6081-4640-b3fb-d0672ecb480/iso-dis-17279-3>

THIS DOCUMENT IS A DRAFT CIRCULATED FOR COMMENT AND APPROVAL. IT IS THEREFORE SUBJECT TO CHANGE AND MAY NOT BE REFERRED TO AS AN INTERNATIONAL STANDARD UNTIL PUBLISHED AS SUCH.

IN ADDITION TO THEIR EVALUATION AS BEING ACCEPTABLE FOR INDUSTRIAL, TECHNOLOGICAL, COMMERCIAL AND USER PURPOSES, DRAFT INTERNATIONAL STANDARDS MAY ON OCCASION HAVE TO BE CONSIDERED IN THE LIGHT OF THEIR POTENTIAL TO BECOME STANDARDS TO WHICH REFERENCE MAY BE MADE IN NATIONAL REGULATIONS.

RECIPIENTS OF THIS DRAFT ARE INVITED TO SUBMIT, WITH THEIR COMMENTS, NOTIFICATION OF ANY RELEVANT PATENT RIGHTS OF WHICH THEY ARE AWARE AND TO PROVIDE SUPPORTING DOCUMENTATION.

This document is circulated as received from the committee secretariat.



Reference number
ISO/DIS 17279-3:2020(E)

© ISO 2020

iTeh STANDARD PREVIEW
(standards.iteh.ai)
Full standard:
<https://standards.iteh.ai/catalog/standards/sist/67a9a027-6081-4640-b3fb-d0672ecb480/iso-dis-17279-3>



COPYRIGHT PROTECTED DOCUMENT

© ISO 2020

All rights reserved. Unless otherwise specified, or required in the context of its implementation, no part of this publication may be reproduced or utilized otherwise in any form or by any means, electronic or mechanical, including photocopying, or posting on the internet or an intranet, without prior written permission. Permission can be requested from either ISO at the address below or ISO's member body in the country of the requester.

ISO copyright office
CP 401 • Ch. de Blandonnet 8
CH-1214 Vernier, Geneva
Phone: +41 22 749 01 11
Fax: +41 22 749 09 47
Email: copyright@iso.org
Website: www.iso.org

Published in Switzerland

Contents

	Page
Foreword	v
Introduction	vi
1 Scope	1
2 Normative references	1
3 Terms and definitions	1
4 Symbols and abbreviated terms	1
5 Test methods for joint	1
5.1 General	1
5.2 Visual testing	2
5.2.1 Scope	2
5.2.2 Qualification of test personnel	2
5.2.3 Test equipment	2
5.2.4 Surface condition and preparation	2
5.2.5 Testing	2
5.2.6 Acceptance criteria	3
5.2.7 Test report	3
5.3 Four-point-probe testing	3
5.3.1 Scope	3
5.3.2 Qualification of test personnel	3
5.3.3 Test equipment	3
5.3.4 Surface condition and preparation	3
5.3.5 Testing	3
5.3.6 Acceptance criteria	9
5.3.7 Test report	9
5.4 Field-decay testing	9
5.4.1 Scope	9
5.4.2 Qualification of test personnel	9
5.4.3 Test equipment	9
5.4.4 Surface condition and preparation	9
5.4.5 Testing	9
5.4.6 Acceptance criteria	12
5.4.7 Test report	12
5.5 In-field testing	12
5.5.1 Scope	12
5.5.2 Qualification of test personnel	12
5.5.3 Test equipment	12
5.5.4 Surface condition and preparation	12
5.5.5 Testing	12
5.5.6 Acceptance criteria	13
5.5.7 Test report	13
5.6 Tensile testing	13
5.6.1 Scope	13
5.6.2 Qualification of test personnel	13
5.6.3 Test equipment	14
5.6.4 Surface condition and preparation	14
5.6.5 Testing	14
5.6.6 Acceptance criteria	14
5.6.7 Test report	14
5.7 Bend testing	15
5.7.1 Scope	15
5.7.2 Qualification of test personnel	15
5.7.3 Test equipment	15

5.7.4	Surface condition and preparation	15
5.7.5	Testing	15
5.7.6	Acceptance criteria	16
5.7.7	Test report	16
5.8	Critical magnetic field testing	16
5.8.1	Scope	16
5.8.2	Qualification of test personnel	16
5.8.3	Test equipment	16
5.8.4	Surface condition and preparation	16
5.8.5	Testing	16
5.8.6	Acceptance criteria	17
5.8.7	Test report	17
5.9	Critical current density distribution testing	17
5.9.1	Scope	17
5.9.2	Qualification of test personnel	17
5.9.3	Test equipment	17
5.9.4	Surface condition and preparation	17
5.9.5	Testing	17
5.9.6	Acceptance criteria	18
5.9.7	Test report	18
5.10	Microscopic and X-ray diffraction testing	18
5.10.1	Scope	18
5.10.2	Qualification of test personnel	18
5.10.3	Test equipment	18
5.10.4	Surface condition and preparation	18
5.10.5	Testing	18
5.10.6	Acceptance criteria	19
5.10.7	Reporting	19
Annex A (normative) Report of visual testing results		20
Annex B (normative) Report of four-point-probe testing results		22
Annex C (normative) Report of field-decay testing result		25
Annex D (normative) Report of in-field testing results		28
Annex E (informative) Report of tensile testing results		30
Annex F (informative) Report of bend testing results		32
Annex G (informative) Report of critical magnetic field testing results		34
Annex H (informative) Report of critical current density distribution testing results		36
Annex I (informative) Report of microscopic and X-ray diffraction testing results		38
Bibliography		40

Foreword

ISO (the International Organization for Standardization) is a worldwide federation of national standards bodies (ISO member bodies). The work of preparing International Standards is normally carried out through ISO technical committees. Each member body interested in a subject for which a technical committee has been established has the right to be represented on that committee. International organizations, governmental and non-governmental, in liaison with ISO, also take part in the work. ISO collaborates closely with the International Electrotechnical Commission (IEC) on all matters of electrotechnical standardization.

The procedures used to develop this document and those intended for its further maintenance are described in the ISO/IEC Directives, Part 1. In particular, the different approval criteria needed for the different types of ISO documents should be noted. This document was drafted in accordance with the editorial rules of the ISO/IEC Directives, Part 2 (see www.iso.org/directives).

Attention is drawn to the possibility that some of the elements of this document may be the subject of patent rights. ISO shall not be held responsible for identifying any or all such patent rights. Details of any patent rights identified during the development of the document will be in the Introduction and/or on the ISO list of patent declarations received (see www.iso.org/patents).

Any trade name used in this document is information given for the convenience of users and does not constitute an endorsement.

For an explanation of the voluntary nature of standards, the meaning of ISO specific terms and expressions related to conformity assessment, as well as information about ISO's adherence to the World Trade Organization (WTO) principles in the Technical Barriers to Trade (TBT), see www.iso.org/iso/foreword.html.

This document was prepared by Technical Committee ISO/TC 44, *Welding and allied processes*, Subcommittee SC 10, *Quality management in the field of welding*.

A list of all parts in the ISO 17279 series can be found on the ISO website.

ISO 17279 consists of the following parts, under the general title *Welding — Micro-joining of 2nd generation high temperature superconductors*:

- *Part 1: General requirements for the procedure*
- *Part 2: Qualification for welding and testing personnel*
- *Part 3: Test methods for joint*

Any feedback or questions on this document should be directed to the user's national standards body. A complete listing of these bodies can be found at www.iso.org/members.html.

Introduction

The increasing use of 2nd generation high temperature superconductors (2G HTSs) and invention of resistance-free joining on 2G HTSs have created the need for this International Standard in order to ensure that joining is carried out in the most effective way and that appropriate control is exercised over all aspects of the operation. ISO standards for micro-joining and joint evaluation procedure are accordingly essential to get the best and uniform quality of 2G HTS joint.

Superconductor is a material that conducts electricity without resistance and has diamagnetism below critical temperature (T_c), critical magnetic field (B_c) and critical current density (J_c). Once set in motion, electrical current flows forever in a closed loop of superconducting material under diamagnetism.

2G HTS constitutes of multi-layers and total thickness is around 60 to 90 μm and the superconducting layer made from $\text{REBa}_2\text{Cu}_3\text{O}_{7-x}$ is only 1 μm to 3 μm thick depending on manufacturer's specifications. [Figure 1](#) shows schematic drawing of typical multiple layers, and the constituents and thicknesses of each layer in the 2G HTS.

Dimensions in micro-meters

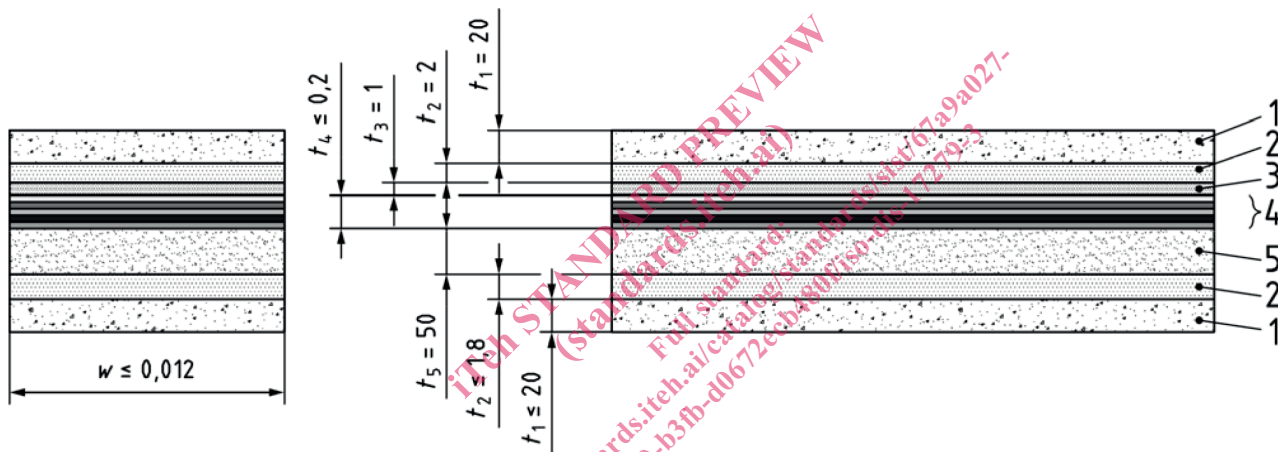

Key

- 1 Cu stabilizer
- 2 Ag overlayer
- 3 REBCO-superconducting layer
- 4 buffer stack
- 5 Hastelloy®C-276 substrate

NOTE Not to scale.

Figure 1 — Typical 2G HTS multi-layers, and the constituents and thicknesses of each layer

Currently soldering, brazing or any filler is applying in superconducting industry as shown in [Figure 2](#), which shows high electrical resistance at the joint providing fatal flaw in the superconductor.

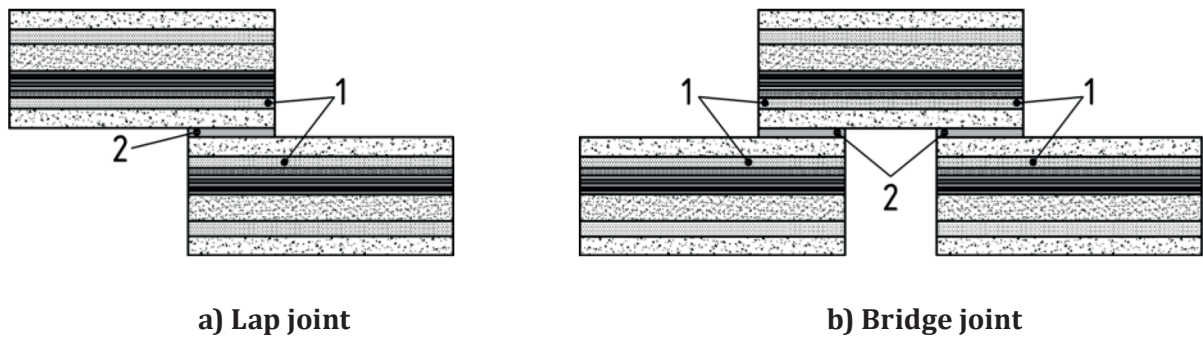
**Key**

- 1 REBCO-superconducting layer
- 2 solder

Figure 2 — Soldering to join 2G HTS

However, this standard focuses on the direct autogenous joining of 1 μm to 3 μm thick superconducting layers of 2G HTSs as shown in Figure 3 without filler metals and recovery of superconducting properties by oxygenation annealing process, which shows almost none electrical resistance at the joint.

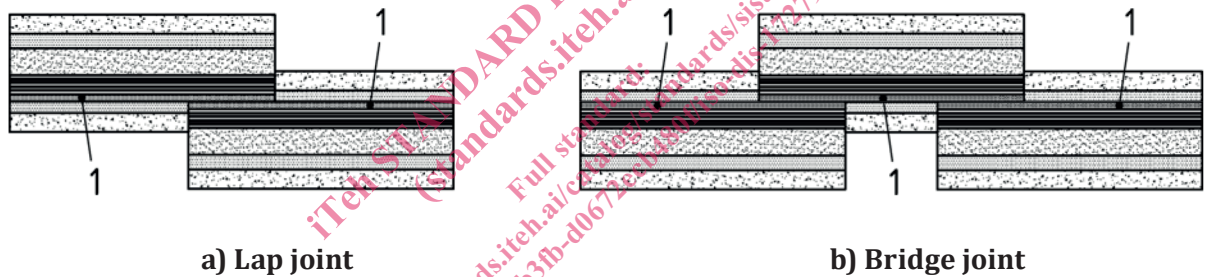
**Key**

- 1 REBCO-superconducting layer

Figure 3 — Direct autogenous joining of 1 μm to 3 μm thick superconducting layers of 2G HTSs for superconducting joint

The parts of this International Standard are listed in the foreword.

Part 1 specifies requirements for the qualification of 2G HTS joining procedure. 2G HTS joints should be capable of performing required electric, magnetic and mechanical properties and free from serious imperfections in production and in service. To achieve that goal, it is necessary to provide controls during design and fabrication.

Part 2 specifies requirements for the qualification of personnel performing welding and testing.

Part 3 specifies test methods for determining the capability of joints for the production of the specified quality. It defines specific test requirements, but does not assign those requirements to any specific product group.

iTeh STANDARD PREVIEW
(standards.iteh.ai)

Full standard:
<https://standards.iteh.ai/catalog/standards/sist/67a9a027-6081-4640-b3fb-d0672ecb480/iso-dis-17279-3>

Welding — Micro joining of 2nd generation high temperature superconductors —

Part 3: Test methods for joints

1 Scope

This document specifies the requirements for the test methods for joint of micro-joining of 2G HTS to fulfil the ISO 17279-1 and ISO 17279-2 requirements.

2 Normative references

The following documents are referred to in the text in such a way that some or all of their content constitutes requirements of this document. For dated references, only the edition cited applies. For undated references, the latest edition of the referenced document (including any amendments) applies.

ISO 17279-1:2019, *Welding — Micro-joining of 2nd generation high temperature superconductors — Part 1: General Requirements for the procedure*

ISO 17279-2, *Welding — Micro joining of 2nd generation high temperature superconductors — Part 2: Qualification for welding and testing personnel*

ISO 15607:2019, *Specification and qualification of welding procedures for metallic materials — General rules*

3 Terms and definitions

For the purposes of this document, the terms and definitions given in ISO 17279-1 and ISO 15607:2019, Table 1 may apply if the terms are relevant to joining procedure for 2G HTS, apply.

No terms and definitions are listed in this document.

ISO and IEC maintain terminological databases for use in standardization at the following addresses:

- ISO Online browsing platform: available at <http://www.iso.org/obp>
- IEC Electropedia: available at <http://www.electropedia.org/>

4 Symbols and abbreviated terms

For the purposes of this document, the symbols and abbreviated terms given in ISO 17279-1 and ISO 15607:2019, Table 1 may apply if the symbols and abbreviated terms are relevant to joining procedure for 2G HTS, apply.

5 Test methods for joint

5.1 General

ISO 17279-1:2019, 5.5.4 describes requirements of testing personnel qualification, test methods, witness during testing of the test specimens, and re-test. Especially, ISO 17279-1:2019, Table 1, shows type of testing, extent of testing, confirmation of testing, and required tests for procedure qualification

according to ISO 17279-1. ISO 17279-1:2019, 5.9, requires the acceptance criteria of the tests. Manufacturer may have at their disposal sufficient competent personnel for the testing and operating the test equipment, or may contract the specific tests to the specialized organizations. Manufacturer may witness the tests from specimen preparation to data acquisition and analysis according to manufacturer's quality assurance requirements.

The operating procedures and cautions of the test equipment shall be applied when the equipment is used for testing according to this standard. The operator of the specific equipment shall establish the capability to perform the required test, and calibration and qualification of the test equipment shall be maintained up to date according to appropriate quality assurance program. Qualification records and certificates shall be kept up to date.

The tests except visual testing are carried out at the cryogenic environment and do not purport to address the safety concerns associated with its use. It is the responsibility of whoever uses this method to establish appropriate safety and health practices prior to use.

5.2 Visual testing

5.2.1 Scope

This clause defines the method of visual testing of materials and joints used in 2G HTS.

5.2.2 Qualification of test personnel

Testing shall be conducted by qualified personnel to carry out the testing. Personnel qualification shall be done according to appropriate quality assurance program. Personnel conducting visual testing shall annually pass an examination where their vision, with or without correction, meets the Jaeger J2 near vision test at a distance of not less than 30,5 cm as well as a colour perception test. Vision examination records shall be maintained for the current year and must be available for review.

5.2.3 Test equipment

Calibrated and certified instruments shall be used for testing, wherever required, and may include measuring instruments and gauges.

5.2.4 Surface condition and preparation

The surface for the test shall be uniform and smooth and shall be clean and free of scale, rust, oil, grease, detrimental oxides and other deleterious foreign materials such as Ag or Cu spots of 2G HTS. The surfaces of the finished joints shall be suitable to permit proper testing. All joint preparations shall meet drawing specified dimensions (whether provided via dimensions on the drawing or in a welding specification). If no dimensions are provided as part of the drawing or ordering documents, the dimensions shall meet dimensions specified by approved welding procedure specification (WPS).

5.2.5 Testing

Testing shall be performed in accordance with a written procedure or method applicable under testing. The testing area shall include the joint and the accessible adjacent heat-affected zone (HAZ) for some distance from the joint edge of the base metal. The testing shall be in the after joining and final heat treated condition (oxygenation annealing), or otherwise required, and be free of all coatings and other surface conditions such as paint, plating, etc. The joints shall be tested in the as-welded condition. Testing will be conducted with specimen suitable dimensions.

Direct visual testing shall be used. If required, mirrors and magnifying lenses will be used to improve the angle of vision and to assist. The minimum light intensity at the surface will be 1,000 Lux (100 foot-candles). The written procedure or method shall include, at a minimum and either directly or by reference to applicable document(s), procedure identification number and date, revision number,

identification of joints, complete testing requirements including lighting and method of testing, evaluation of indications, acceptance criteria, disposition of joints after evaluations.

5.2.6 Acceptance criteria

The requirements of ISO 17279-1:2019, 5.9, Table 4, shall be met. Lack of bonding, lack of fusion, cracks and pin holes are not acceptable.

5.2.7 Test report

After the completion of the testing, the results shall be entered in the test report. A form of a test report is shown in [Annex A](#).

5.3 Four-point-probe testing

5.3.1 Scope

This clause defines the method of four-point-probe testing of base materials and joints used in 2G HTS. Critical current (I_c), critical current density (J_c) and n -value can be measured from the test.

NOTE Typically the resistance of the point of contact (contact resistance) is far smaller than the resistance of the test specimen, and can thus be ignored. However, for superconductors under cryogenic conditions, the contact resistance can dominate and completely obscure changes in the resistance of the test specimen itself. The effects of contact resistance are eliminated with the use of four-point-probe testing.

5.3.2 Qualification of test personnel

Testing shall be conducted by qualified personnel to carry out the testing. Personnel qualification shall be done according to appropriate quality assurance program.

5.3.3 Test equipment

Calibrated and certified instruments shall be used for testing.

5.3.4 Surface condition and preparation

Sub-clause [5.2.4](#) shall apply.

5.3.5 Testing

5.3.5.1 General

Testing shall be performed in accordance with a written test procedure or method applicable to the 2G HTS. The written test procedure or method shall include, at a minimum and either directly or by reference to applicable document(s), procedure identification number, date, revision number, identification of joints, complete testing requirements including method of testing, evaluation, and reporting after evaluations.

The testing area shall include the joint and the accessible adjacent HAZ of base material for some distance from the joint edge. The total length of specimen shall be at least 60 mm including 20 mm joint. The test shall be done after joining and final heat treated condition (oxygenation annealing), or otherwise required and is carried out at the LN₂ cryogenic environment or other temperature determined by manufacturer. The test shall be done at weld reinforced condition with commercially available materials considering thermal shrinkage coefficient so as not for joints to be damaged during the test.

Schematic of two superconducting layers with lap-joint in 2G HTS is shown in Figure 4. When current passes through a superconducting layer (1 μm to 3 μm thick) of 2G HTS from superconducting layer 1 to

joint to superconducting layer 2, the current generates a voltage difference between superconducting layer 1 and superconducting layer 2. 2G HTS without joint and HAZ is resistance-free in cryogenic environment, thus the most voltage difference comes from joint and HAZ.

Dimensions in micro-meters

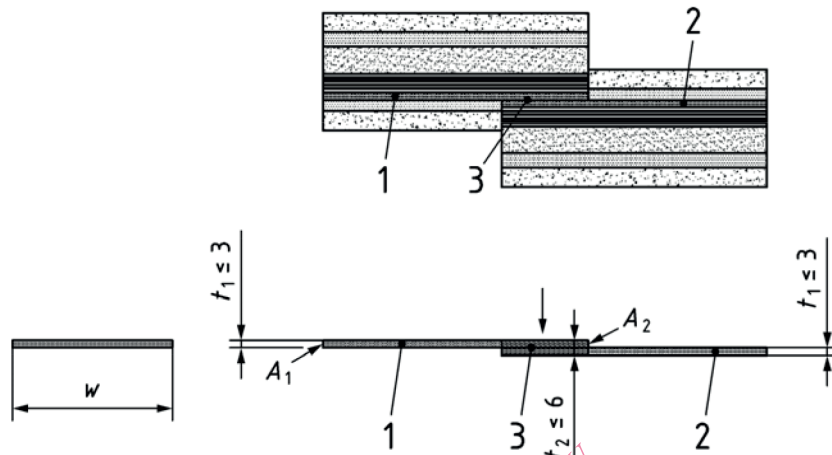

Key

- 1 upper superconducting layer
- 2 bottom superconducting layer
- 3 joining area
- w width of superconducting layer
- t_1 thickness of superconducting layer (1~3 μm)
- t_2 almost 2 t_1 or slightly less than 2 t_1 depending on pressure during joining
- A_1 cross sectional area of superconducting layer 1 & 2 ($A_1 = t_1 \times w$)
- A_2 cross sectional area of lap-joined two superconducting layers ($A_2 = t_2 \times w$)

Figure 4 — Typical 2G HTS multi-layers, and the constituents and thicknesses of each layer

Figure 5 is a schematic of four-point-probe testing in lap-joined 2G HTS. Four probes are attached to the test specimen as shown in the figure. A current is made to flow the length of the test specimen through probes labelled a & b in the Figure 5. This can be done using a current source or a power supply having current output readout. If the test specimen has any resistance to the flow of electrical current, then there will be a drop of potential (or voltage) as the current flows along the test specimen, for example between the two probes labelled c and d in the figure. The voltage drop between probes c and d can be measured by a digital voltmeter. The resistance of the test specimen between probes c and d is the ratio of the voltage registering on the digital voltmeter to the value of the output current of the power supply. The high impedance of the digital voltmeter minimizes the current flow through the portion of the circuit comprising the voltmeter. Thus, since there is no potential drop across the contact resistance associated with probes c and d, only the resistance associated with the joint and associated HAZ of superconductor between probes c and d is measured as a function of current. 2 HAZ lengths adjacent to the joint are about twice of joint length. However the HAZ is dependent on the heat input and dwell time during joining. Manufacturer may determine the HAZ length by four-point-probe testing.