

FINAL
DRAFT

INTERNATIONAL
STANDARD

ISO/FDIS
23435

ISO/TC 146/SC 5

Secretariat: DIN

Voting begins on:
2021-12-01

Voting terminates on:
2022-01-26

Air quality — Test methods for snow depth sensors

iTeh STANDARD PREVIEW
(standards.iteh.ai)

[ISO/FDIS 23435](https://standards.iteh.ai/catalog/standards/sist/6a3c40eb-f9e0-4991-82bd-9864ecc6304a/iso-fdis-23435)

<https://standards.iteh.ai/catalog/standards/sist/6a3c40eb-f9e0-4991-82bd-9864ecc6304a/iso-fdis-23435>

RECIPIENTS OF THIS DRAFT ARE INVITED TO SUBMIT, WITH THEIR COMMENTS, NOTIFICATION OF ANY RELEVANT PATENT RIGHTS OF WHICH THEY ARE AWARE AND TO PROVIDE SUPPORTING DOCUMENTATION.

IN ADDITION TO THEIR EVALUATION AS BEING ACCEPTABLE FOR INDUSTRIAL, TECHNOLOGICAL, COMMERCIAL AND USER PURPOSES, DRAFT INTERNATIONAL STANDARDS MAY ON OCCASION HAVE TO BE CONSIDERED IN THE LIGHT OF THEIR POTENTIAL TO BECOME STANDARDS TO WHICH REFERENCE MAY BE MADE IN NATIONAL REGULATIONS.



Reference number
ISO/FDIS 23435:2021(E)

© ISO 2021

iTeh STANDARD PREVIEW (standards.iteh.ai)

[ISO/FDIS 23435](https://standards.iteh.ai/catalog/standards/sist/6a3c40eb-f9e0-4991-82bd-9864ecc6304a/iso-fdis-23435)

<https://standards.iteh.ai/catalog/standards/sist/6a3c40eb-f9e0-4991-82bd-9864ecc6304a/iso-fdis-23435>



COPYRIGHT PROTECTED DOCUMENT

© ISO 2021

All rights reserved. Unless otherwise specified, or required in the context of its implementation, no part of this publication may be reproduced or utilized otherwise in any form or by any means, electronic or mechanical, including photocopying, or posting on the internet or an intranet, without prior written permission. Permission can be requested from either ISO at the address below or ISO's member body in the country of the requester.

ISO copyright office
CP 401 • Ch. de Blandonnet 8
CH-1214 Vernier, Geneva
Phone: +41 22 749 01 11
Email: copyright@iso.org
Website: www.iso.org

Published in Switzerland

Contents

	Page
Foreword	v
Introduction	vi
1 Scope	1
2 Normative references	1
3 Terms and definitions	1
4 Fundamentals of snow depth sensors	2
4.1 Overview.....	2
4.2 Observation methods.....	2
4.3 Points to note.....	2
5 Test criteria and summary of methods	2
5.1 Test criteria and considerations.....	2
5.1.1 Measurement performance.....	2
5.1.2 Installation-related.....	3
5.1.3 Environmental/operational.....	3
5.2 Summary of test methods.....	3
6 Manufacturer design specifications check	4
6.1 Purpose.....	4
6.2 Requirements to list.....	4
7 Basic functional test	4
7.1 Purpose.....	4
7.2 Calibration of the sensor prior to testing.....	4
7.2.1 Calibration using a reference object.....	4
7.2.2 Calibration by moving the target surface.....	5
7.2.3 Plumb procedure (only applicable to sensors using visible laser signals).....	6
7.3 Basic functional test procedure.....	7
7.3.1 Test setup.....	7
7.3.2 Running test.....	7
7.3.3 Evaluation of the results.....	8
7.3.4 Consideration.....	8
8 Temperature chamber test (optional)	8
8.1 Purpose.....	8
8.2 Test chamber.....	8
8.3 Procedure.....	8
8.4 Evaluation.....	9
9 Calibration (ground level adjust) test	9
9.1 Purpose.....	9
9.2 Procedures.....	9
10 Field tests	9
10.1 Purpose.....	9
10.2 Duration.....	9
10.3 Siting.....	10
10.3.1 Climate.....	10
10.4 Installation.....	11
10.4.1 Mounting and installation of ultrasonic snow depth sensors.....	11
10.4.2 Mounting and installation of laser-based sensors.....	11
10.5 Field site equipment.....	12
10.5.1 Target surface (snow plate).....	12
10.5.2 Reference measurements for comparison.....	12
10.5.3 Auxiliary environmental sensors.....	13
10.6 Evaluation.....	13

10.6.1 Malfunctions	13
10.6.2 Automatic quality control	13
10.6.3 Evaluation of differences to reference	13
10.6.4 Errors caused by field inhomogeneity or other unexpected conditions	13
Bibliography	14

iTeh STANDARD PREVIEW
(standards.iteh.ai)

[ISO/FDIS 23435](https://standards.iteh.ai/catalog/standards/sist/6a3c40eb-f9e0-4991-82bd-9864ecc6304a/iso-fdis-23435)

<https://standards.iteh.ai/catalog/standards/sist/6a3c40eb-f9e0-4991-82bd-9864ecc6304a/iso-fdis-23435>

Foreword

ISO (the International Organization for Standardization) is a worldwide federation of national standards bodies (ISO member bodies). The work of preparing International Standards is normally carried out through ISO technical committees. Each member body interested in a subject for which a technical committee has been established has the right to be represented on that committee. International organizations, governmental and non-governmental, in liaison with ISO, also take part in the work. ISO collaborates closely with the International Electrotechnical Commission (IEC) on all matters of electrotechnical standardization.

The procedures used to develop this document and those intended for its further maintenance are described in the ISO/IEC Directives, Part 1. In particular, the different approval criteria needed for the different types of ISO documents should be noted. This document was drafted in accordance with the editorial rules of the ISO/IEC Directives, Part 2 (see www.iso.org/directives).

Attention is drawn to the possibility that some of the elements of this document may be the subject of patent rights. ISO shall not be held responsible for identifying any or all such patent rights. Details of any patent rights identified during the development of the document will be in the Introduction and/or on the ISO list of patent declarations received (see www.iso.org/patents).

Any trade name used in this document is information given for the convenience of users and does not constitute an endorsement.

For an explanation of the voluntary nature of standards, the meaning of ISO specific terms and expressions related to conformity assessment, as well as information about ISO's adherence to the World Trade Organization (WTO) principles in the Technical Barriers to Trade (TBT), see www.iso.org/iso/foreword.html (standards.iteh.ai)

This document was prepared by Technical Committee ISO/TC 146, *Air quality*, Subcommittee SC 5, *Meteorology*.

<https://standards.iteh.ai/catalog/standards/sist/6a3c40eb-f9e0-4991-82bd-9864e1c36101/iso-fdis-23435>

Any feedback or questions on this document should be directed to the user's national standards body. A complete listing of these bodies can be found at www.iso.org/members.html.

Introduction

Solid precipitation is one of the more complex parameters to be observed and measured by automatic sensors. The measurement of precipitation has been the subject of a multitude of studies, but there has been limited information regarding the procedures and performance criteria describing the ability and reliability of automatic sensors to accurately measure solid precipitation^[13].

Recently, an increasing percentage of precipitation data used in a variety of applications have been obtained using automatic instruments and stations including the measurement of snow depth, and many new applications have emerged^[13]. Also, the modern data processing capabilities, data management, and data assimilation techniques provide the means for better assessment and error analysis.

For the past years, various automatic snow depth measurement systems or snow depth sensors have been deployed and tested at different places to take advantages of their efficiency and get more objective measurement results^[6].

An ultrasonic snow depth sensor measures the time interval between transmission and reception of ultrasonic pulses reflected from a target surface. This measurement is used to determine the distance between the sensor and the surface. The performance of the acoustic snow depth measurement technique depends on air temperature, and the ultrasonic sensor requires to be corrected for variations of the speed of sound in air. The measurement uncertainty of sonic rangefinders (distance meters) is 0,5 % to 1 % of the distance, which leads under typical conditions to a measurement uncertainty for snow depth in the order of 1 cm^[2].

Laser sensors for snow depth measurement were introduced a few years ago and have already been under test and in operational use in various places^{[11][14][18]}. A laser snow depth sensor uses an optoelectronic distance measurement principle to measure the distance between the sensor and the surface of the snow. Most of the laser snow sensors today employ a single laser distance meter, and, this result in an important drawback of this type of snow sensors, the lack of spatial representativeness. To resolve this issue, there have been a few trials and products with multipoint measurements, including a fixed 3 points sensor and scanning laser snow depth sensors which scan multiple points along a circular path or a segment of line. Apart from the laser distance sensors, there are other optical techniques capable of measurement of the state of ground and snow depth^[2].

In spite of some of the drawbacks and difficulties, automated snow depth measurement techniques are evolving to offer more objective results which can be made available continuously and in near real-time.

The procedures presented in this document define methods for performance test of snow depth sensors to be used for snow depth measurements. Minimum requirements for conformance with this document include successful completion of the basic functional test (see [Clause 7](#)), the temperature chamber test (see [Clause 8](#)), and the field test (see [Clause 10](#)).

Air quality — Test methods for snow depth sensors

1 Scope

This document provides requirements for the evaluation and use of test method for snow depth sensors. This document is applicable to the following types of automatic snow depth sensors which employ different ranging technologies by which the sensors measure the distance from the snow surface to the sensor:

- a) Ultrasonic type, also known as sonic ranging depth sensors;
- b) Optical laser snow depth sensors including single point and multipoint snow depth sensors;
- c) Other snow depth sensors.

This document mainly covers two major tests: a laboratory(indoor) test and a field (outdoor) test. The laboratory test includes the basic performance test and other tests under various environmental changes. The field test is proposed to ensure the performance of the snow depth sensors in field measurement conditions. For the field test, both the natural ground and artificial target surface such as snow plates are considered for the procedures defined in this document.

2 Normative references

The following documents are referred to in the text in such a way that some or all of their content constitutes requirements of this document. For dated references, only the edition cited applies. For undated references, the latest edition of the referenced document (including any amendments) applies.

ISO 5725 (all parts), *Accuracy (trueness and precision) of measurement methods and results*

3 Terms and definitions

For the purposes of this document, the following terms and definitions apply.

ISO and IEC maintain terminological databases for use in standardization at the following addresses:

- ISO Online browsing platform: available at <https://www.iso.org/obp>
- IEC Electropedia: available at <https://www.electropedia.org/>

3.1

mean

mean value over the (selected) averaging interval of the sonic

3.2

dead zone

area that cannot be measured near the sensor

3.3

half-power beam width

beam angle width that the transmitted acoustic power decreases by half

3.4

beam angle clearance

angular range where obstacles should be excluded to prevent interference due to acoustic reflection

4 Fundamentals of snow depth sensors

4.1 Overview

The term “snow” should also include ice pellets, glaze, hail, and sheet ice formed directly or indirectly from precipitation. Snow depth usually means the total depth of snow on the ground at the time of observation. Depth measurements of snow cover on the ground had been taken mainly with snow rulers until a couple of decades ago. The development of practical ultrasonic and laser ranging devices to provide reliable snow depth measurements at automatic stations has provided feasible alternatives to the standard observation. Most of these sensors are capable of an uncertainty within $\pm 1,0$ cm (WMO-No.8 the CIMO Guide, 2018). In addition, these sensors can be utilized to control the quality of automatic recording gauge measurements by providing additional details on the type, amount and timing of precipitation.

4.2 Observation methods

The ultrasonic snow depth sensor has an ultrasonic wave transmitter/receiver installed downward on the upper part of the observation pole, emits an ultrasonic pulse, and measures the time it takes for the ultrasonic pulse to be reflected and returned. The depth of snow is calculated by converting the propagation time and the speed of sound into distance.

The laser snow depth sensor uses laser light instead of the ultrasonic waves. Laser light is emitted obliquely downward from the upper part of the observation pole. The laser light has a spot shape on the irradiated snow surface, and there are single-point laser sensors and multi-point laser sensors that measure a single point and multiple points on the snow surface respectively.

4.3 Points to note

There are a few points to note. Firstly, measurements should be taken at the representative observing point without slope and with no obstructions around measurement points, since the snow drifts and is redistributed under the effects of the wind.

Secondly, since the ultrasonic snow depth sensor has a wide beam, it requires a wide irradiation surface.

Thirdly, a single-point laser sensor requires attention to be paid to the snow surface representativeness of the measurement point.

5 Test criteria and summary of methods

5.1 Test criteria and considerations

5.1.1 Measurement performance

- 1) Resolution: the minimum measurement unit in 0,1 cm. (typical e.g. 0,1 cm)
- 2) Measurement accuracy: deviation of the measurement from the real depth in 0,1 cm. (typical e.g. 0,5 cm)
- 3) Dead zone: area that cannot be measured near the sensor. (typical e. g. 50 cm from the centre of the target area)
- 4) Measurement height range: maximum measurable snow height considering dead zone in cm. (typical e.g. 300 cm).
- 5) Maximum measurable distance from the ground and/or "dead-zone" in cm. (typical e.g. 500 cm)
- 6) Measurement area (in cm^2): the size of the target area (typical e.g. 100 cm in radius (approx. 7 850 cm^2). For ultrasonic sensors, the measurement area is limited by the “half-power beam

width" not the "beam angle clearance. The former is usually within 10 deg., on the other hand the latter is about 30 deg.

- 7) Measurement pattern: the shape of the scanning measurement (e.g. a single point, a triangle, a rectangle, a circle, a line etc.).
- 8) Measurement speed: minimum measurement period or data output interval. (typical e.g. 1 min)

5.1.2 Installation-related

- 1) Allowed installation angle: the maximum angle between the vertical pole or wall and the pointing direction of the snow depth sensor.
- 2) Influence of shadows: the influence of shadows generated by obstacles such as cables, tree branches, poles, and other snow depth meters.
- 3) Max height: the maximum height where the snow sensor should perform measurement with the proclaimed accuracy and resolution; it is to determine if the maximum measurable height is bigger than the maximum possible snow depth at the site.
- 4) Target surface: determine if the target surface, either natural ground or a snow plate is structured for optimal measurement of snow depth.
- 5) Calibration procedure: determine if there is a straight forward procedure to calibrate the sensor.

5.1.3 Environmental/operational

- 1) Snow measuring temperature: temperature range where the snow sensor should perform measurement with the proclaimed accuracy and resolution. (e.g. -40 ~ 30 °C).
- 2) Operating temperature and humidity where the snow sensor can be operated without being damaged or malfunctions: (e.g. -40 ~ 50 °C, 0 ~ 99 %).
- 3) Wind (ultra-sonic sensors only): (e.g. 0 ~ 20 m/s speed, apply the manufacturer's specification).
- 4) Visibility (laser sensor only): effect of snowstorm, fog and dirt on the snow surface. (apply the manufacturer's specification).
- 5) Conditions of testing and calibration: conditions that have impacts on the performance of the sensor. Although testing in extreme environments should be encouraged, one should not infer results from these tests to the performance that can be expected in less extreme conditions.

5.2 Summary of test methods

- 1) Manufacturer design specifications check: the sensor should be examined for damage and conformance with manufacturer design specifications prior to testing. The accuracy of all measurements and results shall be ascertained and reported in accordance with ISO 5725 (all parts).
- 2) Basic functional test: the instrument's basic performance in terms of resolution, accuracy, and measurement range are tested and determined.
- 3) Temperature chamber test: The deviation of the measured is determined over the operational temperature range.
- 4) Calibration (ground level adjustment) or manual configuration test: the offset of the measured distance is determined over the operational temperature range.
- 5) Field test: addresses the response to potentially adverse environmental conditions, which are difficult to simulate in the laboratory.

6 Manufacturer design specifications check

6.1 Purpose

Check if the measurement performance and specifications proclaimed by the manufacturer meets the intended use.

6.2 Requirements to list

The list includes the sensor's measurement performance, installation related issues including zero adjustment and calibration procedures, and environmental/operational conditions.

7 Basic functional test

7.1 Purpose

The purpose of the basic functional test is to verify the basic performance of the test subject. This clause defines procedures of calibration of the sensors, test setup, and running tests.

7.2 Calibration of the sensor prior to testing

Before any use or test of the sensors, they need to be properly calibrated.

There are different ways to calibrate the snow sensors depending on the measurement types of the sensors. Below is a list of proposed calibration methods:

- 1) Calibration using a reference object;
- 2) Calibration using a moving target surface (or changing the installation height);
- 3) Plumb procedure.

7.2.1 Calibration using a reference object

- 1) In this calibration setup, measurements are done with and without a reference object. The measurement without the reference object is supposed to be same as the measurement for the ground level.
- 2) The installation angle (α) can be derived easily by the formula as shown in [Figure 1](#).
- 3) Adjust the scale, the offset, and other factors so that the resulting output matches the height of the reference object, c .
- 4) In this scheme, if the height of the reference object c is not well determined, the corresponding error in the installation angle, α leads to 1:1 error in the measured distance between the sensor and the surface.

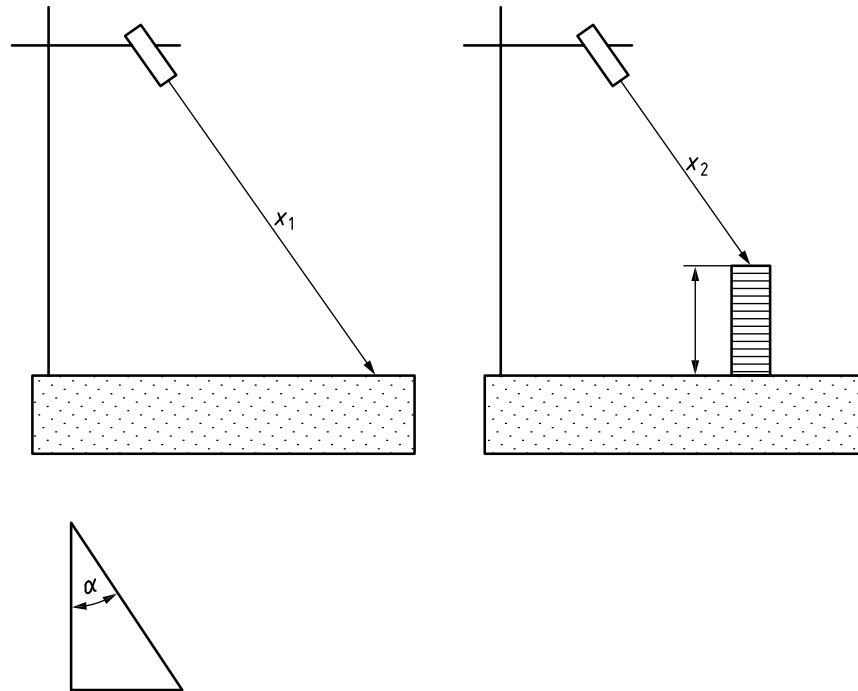
**Key**

- A calibration setup and Measurement without the reference object
 B measurement with reference object
 C calculation of the installation angle
 α installation angle
 c reference object
 x_1 distance from the ground level
 x_2 distance from the top of the reference object c

Figure 1 — Calibration using a reference object

7.2.2 Calibration by moving the target surface

- 1) In this scheme, the direction of the laser beam doesn't have to be perpendicular to the target surface.
- 2) This scheme shown in [Figure 2](#) is virtually equivalent to the one using a reference object in [7.2.1](#), but, the distance between the sensor and the target surface is changed by moving either the sensor or the target surface instead of inserting a reference object in [7.2.1](#).
- 3) First measure the distance m_1 (equivalent to x_1 in [Figure 1](#) of [7.2.1](#)) as the ground level.
- 4) Second measure the distance m_2 (equivalent to x_2 in [Figure 1](#) of [7.2.1](#)) as a reference height.
- 5) Compare $(m_1 - m_2)$ and $(d_1 - d_2)$.

Adjust the scale, the offset, and other factors that the calculated output from $(m_1 - m_2)$ matches the distance moved, $(d_1 - d_2)$. When the sensor's beam is perpendicular to the target surface or the ground (as with ultrasonic snow depth sensors) as shown in [Figure 3](#), the process becomes much simpler. In this scheme $(m_1 - m_2)$ is equal to $(d_1 - d_2)$.

Rail distance d_1 or d_2 corresponds to the height from the ground. Calibration is carried out according to [7.3.2](#) Running test