



Designation: ~~E544–99(Reapproved 2004)~~ Designation: E544 – 10

Standard Practices for Referencing Suprathreshold Odor Intensity¹

This standard is issued under the fixed designation E544; the number immediately following the designation indicates the year of original adoption or, in the case of revision, the year of last revision. A number in parentheses indicates the year of last reapproval. A superscript epsilon (ϵ) indicates an editorial change since the last revision or reapproval.

1. Scope

1.1 These practices are designed to outline a preferred means for referencing the odor intensities of a material in the suprathreshold region.

1.2 The general objective is to reference the odor intensity rather than other odor properties of a sample.

1.3 These practices are designed to reference the odor intensity on the ASTM Odor Intensity Referencing Scale of any odorous material. This is done by a comparison of the odor intensity of the sample to the odor intensities of a series of concentrations of the reference odorant, which is 1-butanol (*n*-butanol).

1.4 The method by which the reference odorant vapors are to be presented for evaluation by the panelists is specified. The manner by which the test sample is presented will depend on the nature of the sample, and is not defined herein.

1.5 Test sample presentation should be consistent with good standard practice (1)² and should be explicitly documented in the test report.

1.6

1.6 The values stated in SI units are to be regarded as standard. No other units of measurement are included in this standard.

1.7 This standard does not purport to address all of the safety concerns, if any, associated with its use. It is the responsibility of the user of this standard to establish appropriate safety and health practices and determine the applicability of regulatory limitations prior to use. See Annex A1 for specific safety data.

2. Referenced Documents

2.1 *ASTM Standards*:³

D1292 [Test Method for Odor in Water](#)

3. Terminology

3.1 *ASTM odor intensity referencing scale*—series of 1-butanol dilutions used to establish which concentration exhibits an odor intensity matching that of the sample.

3.2 *concentration*—series of concentrations of 1-butanol in odorless air, nitrogen, or the water diluent, made to specific reference dilutions which serve as the reference scale, volume basis, of 1-butanol diluted air or in water. In the latter case, the temperature of the solution during the test should be reported.

3.3 *dynamic scale*—reference scale in which vapor dilutions are prepared by continuous mixing of vapors of 1-butanol with an odorless gas, such as air, to yield constant dilutions of vapor in the gas.

3.4 *panelists*—individuals who compare the odor intensity of the sample to the reference scale. These individuals should be able to do this with a consistency described in 5.5.

3.5 *perceived (sensory) odor intensity*—intensity of an odor sensation which is independent of the knowledge of the odorant concentration.

3.6 *sample*—material in any form exhibiting an odor that needs to be measured.

3.7 *static scale*—reference scale in which dilutions of 1-butanol in water are prepared in flasks and presented for odor intensity comparison from the flasks.

3.8 *suprathreshold odor intensity*—perceived (sensory) intensity of the odor in that intensity region in which the odor is clearly experienced.

¹ These practices are under the jurisdiction of ASTM Committee E18 on Sensory Evaluation of Materials and Products and are the direct responsibility of Subcommittee E18.04 on Fundamentals of Sensory.

Current edition approved Dec. 1, 2004; 2010. Published December 2004; 2010. Originally approved in 1975. Last previous edition approved in 1999; 2004 as E544 – 99 (2004). DOI: 10.1520/E0544-99R04.10.1520/E0544-10.

² The boldface numbers in parentheses refer to the list of references at the end of these recommended practices.

³ For referenced ASTM standards, visit the ASTM website, www.astm.org, or contact ASTM Customer Service at service@astm.org. For *Annual Book of ASTM Standards* volume information, refer to the standard's Document Summary page on the ASTM website.

4. Summary of Practice

4.1 The reference odorant used to generate an odor intensity scale is 1-butanol (*n*-butanol). The reasons for its selection are summarized in Appendix X1. A geometric progression scale with a ratio of 2 is recommended, that is, a scale in which each reference dilution differs in its 1-butanol concentration from the preceding dilution by a factor of 2.

4.2 Two procedures, A and B, are described in these recommended practices. They differ in the method by which the diluted 1-butanol vapors are prepared.

NOTE 1—The relationships between the odor intensity of 1-butanol concentrations in air and in water have not been evaluated. Translation of Procedure B data to the numerical values of Procedure A is not possible at this time.

4.2.1 In Procedure A, hereafter referred to as the dynamic scale method, a dynamic-dilution apparatus is used. This is equipped with a series of sniffing ports from which constant concentrations of 1-butanol emerge at constant volumetric flow rates in air.

4.2.2 In Procedure B, hereafter referred to as the static-scale method, a series of Erlenmeyer flasks containing known concentrations of 1-butanol in water is used.

4.3 The odor of the sample is matched, ignoring differences in odor quality, against the odor intensity reference scale of 1-butanol by a panel yielding at least eight independent judgments. Panelists report that point in the reference scale which, in their opinion, matches the odor intensity of the unknown.

4.4 The independent judgments of the panelists are averaged geometrically (see 7.4) with respect to the 1-butanol concentrations of the indicated matching points. Results are reported as an odor intensity, in parts per million, of 1-butanol in air (Procedure A) or water (Procedure B) on the ASTM Odor Intensity Referencing Scale. When water is used as a diluent, the temperature of the reference scale solutions during the test must be reported.

4.5 The odor intensity equivalent values which are obtained may then be used to compare the relative intensities of sample groups. These values are reference values and are not related to the odor intensities by a simple proportionality coefficient (see 8.2).

5. Procedure A—Dynamic-Scale Method

5.1 Reagents:

5.1.1 *1-butanol (n-butanol)*, the reference odorant, with required purity 99+ mol % by gas chromatography. Also shall be free of strong odorous impurities.

5.1.2 *Diluent*—Nonodorous room or cylinder air.

5.2 Preparation of Dynamic Scale:

5.2.1 Prepare the 1-butanol airflow mixtures in an olfactometer apparatus as follows: Pass air over an expanded surface of 1-butanol in order to produce a saturated vapor at a known ambient temperature. Temperatures should be ambient in order to avoid condensation in the airflow lines. Air becomes saturated (98+ %) at flow rates up to 60 mL/min when passed over a surface of 1-butanol that is 120 mm long by 10 mm wide in a 13-mm inside diameter glass tube which is held in a horizontal position. Saturated vapor prepared by bubbling air through 1-butanol is less desirable since the bubbles burst at the surface and produce droplets. In such methods of vapor generation, glass wool filter, operating at the same temperature as the 1-butanol liquid sample, must be used to remove the droplets. Obtain concentrations of vapor below saturation by diluting the saturated vapor with additional volumes of air.

5.2.2 If air, such as pumped ambient air which contains water vapor is used, replace the 1-butanol in the saturation tube every 2 to 3 h; otherwise it will become diluted by the absorption of water which will lower the vapor pressure of 1-butanol, and will result in a lower odorant concentration at the sniffing ports.

5.2.3 An adequate concentration range for most applications is between 5 and 2000 ppm of 1-butanol in air. Above 2000 ppm, the odor intensity is too strong for accurate judgment. Below 5 ppm, the odor is too close to the threshold limit for panelists to make accurate judgments.

5.2.4 The temperature of 1-butanol in the saturation tube should be noted at the start and kept constant during the test. It should be within the range of comfortable room temperatures.

5.2.5 The rate of dynamic delivery of air carrying diluted 1-butanol vapor from sniffing ports should be 160 ± 20 mL/min from a port with a cross-section of 400 to 500 mm², resulting in a nominal linear flow rate of 300 mm/min. A rate that is too slow allows the stimulus to be diluted with increasing amounts of room air. A rate that is too fast creates a mechanical sensation in the nose which complicates the odor intensity judgment.

5.2.6 An example of a dynamic dilution apparatus, called a dynamic olfactometer, is diagrammed in Fig. X1.1 and its operation is explained, in Appendix X4.

5.3 Reference Concentrations:

5.3.1 This practice is intended to establish, on a continuous ppm 1-butanol scale, that ppm value which best corresponds in its odor intensity to the odor intensity of the sample. Since such a scale is technically difficult, the one designed consists of a series of discrete concentration points at sniffing ports continuously delivering known concentrations of 1-butanol vapor in air.

5.3.2 A geometric progression scale of concentrations is used, in which each reference port differs in its 1-butanol concentration from the preceding port by a factor of 2. It would have been desirable to select and always use the same ppm values for the same ports, however, this would require very complex flow adjustment systems. Although the ppm values delivered by the scale ports

change with temperature, they remain in the same ratio to each other, and thus still permit the intensity equivalence point to be easily found.

5.3.3 The scale points are arranged systematically, in the order of increasing concentrations, and are numbered in ascending integers, from 1 for the lowest concentration of 1-butanol.

5.3.4 The matching points normally used are the scale points, or positions between the scale points, but can also be those points beyond either end of the scale.

5.4 *Test Room*—The test room must be well-ventilated, essentially odor-free, and comfortable. In order to avoid bias, waiting panelists should not observe or learn the judgments of the panelist currently matching the odor intensity of the sample to the scale (1, 2).

5.5 *Odor Panel:*

5.5.1 *Number*—The number of panelists should be eight or more, to permit elementary statistical tests on their judgments. A smaller number of panelists may be used with replicate judgments to increase the total to eight or more. It is important when obtaining replicate data that all bias is removed. Precautions such as separate sessions and recoding are recommended (1).

5.5.2 *Selection*—Special training is not needed but precautions must be taken in the selection of the panelists (3). An individual with insufficient sensitivity to detect the odor of 10 ppm of 1-butanol in air should not be a panelist. Also, some individuals have been observed to experience difficulty in matching odor intensities. Prospective panelists can be screened by having them repeatedly match the odor intensity of a known concentration of 1-butanol vapor to the 1-butanol reference scale. Those whose standard deviation in repeated testing exceeds 1.5 scale steps should not be used in the panel. Periodic retesting of panelists may be advisable.

5.6 *Judgment Procedure:*

5.6.1 Panelists are instructed on the nature of the 1-butanol odor intensity reference scale. They are told that the ports are numbered beginning with No. 1, which represents the weakest odor and that the odors increase systematically in intensity with increasing port identification numbers.

5.6.2 Panelists are instructed to smell the unknown sample and then to smell the scale, beginning with its weakest end, and match the unknown to the scale, ignoring differences in the odor quality. They are permitted to check and recheck the unknown against the scale any number of times and should not be hurried or biased by others in any manner.

5.6.3 Panelists are advised that they may report one of the scale points as the best match, or else may report that the best match occurs between two adjacent points, for example, the unknown is stronger than scale point No. 7, but weaker than scale point No. 8.

5.6.4 Panelists should be advised that the odor may also be weaker than the weakest point of the scale, or stronger than the strongest point of the scale.

5.6.5 When his judgment is within scale limits, the panelist should make sure that the selected position is a good match, that is, that the next lower concentration of 1-butanol indeed smells weaker than the unknown, and that the next higher concentration indeed smells stronger.

5.6.6 Panelists report the matching point in terms of the port identification number. When the best match is a position between the scale points, such as between port Nos. 7 and 8, the half-number, 7.5, is used.

5.6.7 During repeated smelling of one or more samples or scale points, olfactory adaptation (fatigue) occurs, rendering the sense of smell less sensitive. However, the relative position of the unknown with respect to the scale is not unduly influenced unless the rates of adaptation to 1-butanol and to the sample are very different. The adaptation rate to 1-butanol has been reported to be average when compared to other odorants (4). Therefore, the complication that may result from differences in the adaptation rate to the unknown and to 1-butanol is minimized by selecting 1-butanol as the reference odorant.

5.6.8 Because of the olfactory adaptation discussed in 5.6.7, a panelist may find that after judging at higher odor intensity points on the scale, he may have difficulty in detecting odor at the lowest points of the scale. A rest of 2 to 5 min will usually correct this effect.

5.6.9 Panelists may differ in the amount of time required to render a judgment. The panelist should be allowed to proceed at a rate comfortable to him. As many as six test stimuli can be handled by a panel of nine in a 1-h session.

6. Procedure B—Static-Scale Method

6.1 The reference odorant is 1-butanol, (see 5.1.1). The diluent is distilled water that is odor-free.

NOTE 2—If diluent other than water is used, equivalent ppm (vol/vol) values will not exhibit matching odor intensities because of differences in molecular weights, densities, and the activity coefficients of 1-butanol in different solvents. Use of other solvents is therefore not recommended.

6.2 Follow the procedures outlined in Section 5, except for 5.2.

6.3 *Preparation of Static Scale:*

6.3.1 Prepare solutions of 1-butanol in water, using pipets and volumetric flasks, following the usual laboratory procedures for solution preparation.

6.3.2 *Procedure*—Place the reference sniffing solutions into standard 500-mL wide-mouth, conical Erlenmeyer flasks (see Test Method D1292). The volume of solution should be 200 mL and should be replaced by new solutions after a maximum period of 2 h. Between sniffings, cover the top of each flask with aluminum foil in order to assure equilibration between the solution and

the air head-space above it. The flasks should be gently shaken by each panelist prior to each sniffing in order to assure equilibrium.

6.3.3 The temperature of the reference solutions during the test should be ambient, and should be noted and kept constant during the test.

6.3.4 The odor threshold of 1-butanol in water is 2.5 ppm at 21°C (5). The useful concentration range for the static scale is above this value but does not extend to the solubility limit of 7.08 % of 30°C (70 800 ppm) (6). At concentrations close to the solubility limit, excess 1-butanol may separate from the solution with temperature change. If this occurs the odor becomes equivalent to that of pure 1-butanol.

6.3.5 Considerable latitude as to the selection of concentrations is allowed. To go from the saturation point to the threshold requires 16 flasks, assuming that each succeeding mix is one half of the preceding concentration (70 800, 35 400, 17 000, 8 850 ppm, etc.). Solutions stronger than 20 000 ppm of 1-butanol exhibit an odor that is too intense for most comparisons.

6.3.6 The most useful concentration range is approximately between 10 and 20 000 ppm, and may be covered by twelve flasks containing 10 ppm in flask No. 1, 20 ppm in flask No. 2, etc. These flasks constitute the static scale. The unknown sample is matched to the static scale in the same manner as in the dynamic method (see 5.6).

7. Calculation

7.1 *Procedure A*—Table 1 lists 1-butanol concentrations, in parts per million, by volume, in vapor at equilibrium with pure, liquid 1-butanol at different temperatures. Use this table to calculate the concentrations of 1-butanol in air (*Procedure A*).

7.1.1 *Example 1*—Assume that the temperature of 1-butanol was 20.3°C and the following linear interpolation of ppm values is used:

$$6513 + [(7000 - 6513)(0.3/1)] = 6659 \text{ ppm} \quad (1)$$

If air saturated with 1-butanol vapor at 20.3°C is further diluted with additional air to obtain a lower concentration, the value of 6659 ppm is divided by the corresponding dilution factors to obtain the values for 1-butanol vapor concentrations at the respective scale points.

7.1.2 For instance, if a 74-mL/min flow of air saturated with 1-butanol vapor is mixed with a 310-mL/min flow of nonodorous air, the resulting 1-butanol vapor concentration would be the following:

$$(6659) [74/(74 + 310)] = 1283 \text{ ppm by volume} \quad (2)$$

TABLE 1 Vapor Pressure and Concentration Data for the 1-Butanol Odor Intensity Scale^A

Temperature, °C	Vapor Pressure, mm Hg ^B	Concentration ^C	log ₁₀ , ppm
12	2.78	3 660	3.56
13	2.99	3 930	3.59
14	3.23	4 250	3.63
15	3.48	4 580	3.66
16	3.74	4 920	3.69
17	4.01	5 280	3.72
18	4.31	5 670	3.75
19	4.61	6 070	3.78
20	4.95	6 510	3.81
21	5.32	7 000	3.85
22	5.69	7 490	3.87
23	6.11	8 040	3.91
24	6.53	8 590	3.93
25	6.97	9 170	3.96
26	7.50	9 870	3.99
27	8.01	10 500	4.02
28	8.55	11 300	4.05
29	9.14	12 000	4.08
30	9.76	12 800	4.11
31	10.42	13 700	4.14
32	11.07	14 600	4.16
33	11.83	15 600	4.19
34	12.63	16 600	4.22
35	13.42	17 700	4.25
36	14.33	18 900	4.28
37	15.78	20 800	4.32

^A *Handbook of Chemistry and Physics*, 50th Ed., Chem. Rubber Publ. Co., Cleveland, OH, 1969–70, p. D-152. See Table on Vapor Pressure Organic Compounds (pressures less than 1 atm). Values given for 1-butanol are: 1 mm Hg, –1.2°C; 10 mm Hg, +30.2°C; and 40 mm Hg, 53.4°C. These three points were used to interpolate for other temperatures. Later editions have deleted this table.

The values of vapor pressures for 12 to 37°C for the table were calculated as follows: the Handbook values of °C were converted to K, the vapor pressures to log(mm Hg), and the least squares fit straight line was calculated for a plot of log(mm) versus reciprocal of the K temperatures. This equation was used to interpolate vapor pressures in mm Hg for the integral °C values in the table.

The conversion of vapor pressures to ppm by volume was conducted as follows: As an example, the vapor pressure of 1-butanol at 25°C is 6.97 mm Hg. Air saturated with 1-butanol vapor at this temperature and 760-mm Hg total pressure contains $(6.97 \times 1\,000\,000)/760 = 9171$ ppm of 1-butanol.

^B 1 mm Hg = 133 Pa.

^C Concentration of 1-butanol in air saturated with 1-butanol vapor.

7.2 *Procedure B*—For the static-scale method, the values of parts-per-million concentrations of 1-butanol in water solutions are known from the method of preparation (see 6.3.1).

7.3 When a panelist indicates that a position between two scale points is the best match, the concentration value for this position is calculated as the geometrical mean of the concentrations at the two adjoining scale points. This applies to both procedures. For example, if the 1-butanol concentrations at points No. 7 and No. 8 are 685 and 1280 ppm, then the concentration that would correspond to the intermediate position of 7.5 is found by the following logarithmic computation:

$$\log (\text{ppm for position 7.5}) = \frac{\log (658) + \log (1280)}{2} = 2.96 \quad (3)$$

Tables of antilogarithms give 918 ppm as the estimate for the 1-butanol concentration at the scale position 7.5.

7.4 *Averaging Panelists' Data*—A geometric average of a group of panelists' judgments is computed and converted into an ASTM Odor Intensity Referencing Scale value, in parts per million of 1-butanol, in a manner illustrated by the following example:

7.4.1 The odor of 3 % vol/vol of anethole dissolved in propylene glycol and prepared in 125-mL Erlenmeyer flasks was evaluated for its odor intensity in comparison to that of a dynamically prepared scale at sniffing ports such as those described in Appendix X4. Nine panelists participated.

Panelist	Matching Sniffing Port No.	1-Butanol Concentration Data	
		ppm (vol/vol)	log (ppm)
1	5	165	2.22
2	6.5	452	2.66
3	7	658	2.88
4	6.5	452	2.66
5	7.5	919	2.96
6	7.5	919	2.96
7	7.5	919	2.96
8	6.5	452	2.66
9	5.5	226	2.35

7.4.2 The mean \log_{10} in parts per million was equal to 2.701. The antilogarithm of 2.701 is 502 ppm of 1-butanol. This would be the best mean for the odor intensity match for the anethole solution. This result should be reported in accordance with Section 8.

7.5 *Standard Deviation*—It is desirable to quote, the standard deviation of the mean \log_{10} (ppm) value (2), for the method of calculation used when reporting the results. For the example given in 7.4.2, the standard deviation of the mean log (ppm) of 2.701 is ± 0.27 .

8. Report

8.1 *Procedure A*—Report the result as follows:

8.1.1 The odor intensity of the sample is equivalent to ___ ppm of 1-butanol (air) on the ASTM Odor Intensity Referencing Scale for Procedure A.

8.2 *Procedure B*—When the diluent is water and the static-scale method is used, report the result as follows:

8.2.1 The odor intensity of the sample is equivalent to ___ ppm of 1-butanol in water, ___ °C, in the ASTM Odor Intensity Referencing Scale for Procedure B.

8.3 Report the standard deviation of the result (see 7.5), if it is calculated. Also report the number of panelists that participated.

8.4 Values that are reported in this manner permit the comparison of odor intensity measurements for the same material to be conducted in different locations by different panels, the comparison of odor intensities for samples which are not available at the same time, and the reconstruction of a reported odor intensity for an unknown material in other laboratories.

9. Keywords

9.1 *n*-butanol; supra threshold odor intensity

ANNEX

(Mandatory Information)

A1. SAFETY DATA FOR 1-BUTANOL

A1.1 *General* —1-butanol is a common chemical used as a solvent for fats, waxes, resins, gums, and varnishes. It is also used in the manufacture of lacquers, detergents, and rayon; in special cleaning applications; and as a fuel. It is not a listed carcinogen and it does not cause lasting damage in case of accidental moderate overexposure. If ingested it is metabolized in a manner analogous to that of ethanol. It is however an irritant for eyes, skin, and the respiratory tract. Prolonged inhalation or ingestion causes dizziness and narcosis. Accordingly, contact times and concentrations of exposure should under no circumstances exceed those required for the application of the method. Exposure to concentrations in excess of the ACGIH Ceiling Value should be avoided or, if deemed necessary, should be kept to a few seconds per exposure. Assessors who experience symptoms of uneasiness

during the test should be allowed the choice of not completing it.

A1.2 *OSHA Requirement*—The Occupational Safety and Health Authority enforces a workplace TLV (Threshold Limit Value) of 100 ppm (300 mg/m³). This refers to an 8-h time-rated average. To determine compliance in a workroom situation, air sampling should be conducted around the user at intervals during the work period, and the average exposure should be calculated.

A1.3 *ACGIH Recommendation*—The American Conference of Governmental Industrial Hygienists, Inc., 6500 Glenway Ave., Bldg. D-7, Cincinnati, OH 45211-4438, recommends a TLV-C (TLV-Ceiling) of 50 ppm (152 mg/m³). The user should obtain the relevant documentation in full. A TLV-C is a momentary value; in a workroom situation, it signals the need to begin air sampling in order to monitor any exposure above this level.

A1.4 *Realistic Assessment*—Determine the number of seconds an assessor is exposed to each concentration, then calculate the 8-h time-rated average. Example: 1 min at 1000 ppm, 2 min at 500 ppm, 4 min at 250 ppm, total $1 \times 1000 + 2 \times 500 + 4 \times 250 = 3000 \text{ ppm} \times \text{min}$. or $3000/60 \times 8 = 6.25 \text{ ppm}$ over 8 h. An assessor performing 4 such assessments within the same 8-h period is exposed to an 8-h time-rated average of $4 \times 6.25 = 25 \text{ ppm}$.

APPENDIXES

(Nonmandatory Information)

X1. SELECTION OF 1-BUTANOL AS THE REFERENCE ODORANT

X1.1 1-Butanol was selected as the reference odorant because:

X1.1.1 It is a common chemical and is readily available in 99+ mol % purity.

X1.1.2 It is non-toxic, except in multigram doses.

X1.1.3 It has good stability in the presence of air and water.

X1.1.4 Its odor is somewhat unrelated, so that its odor quality can be more easily ignored when comparing with other odors which may have different qualities.

X1.1.5 The majority of people do not object to sniffing it frequently when doing odor-intensity referencing.

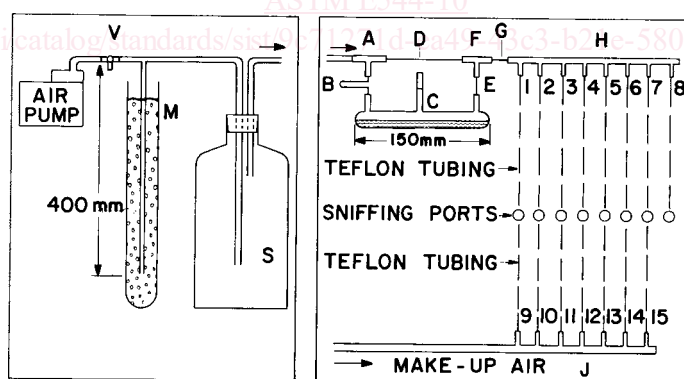

Fig. 1-A

Fig. 1-B

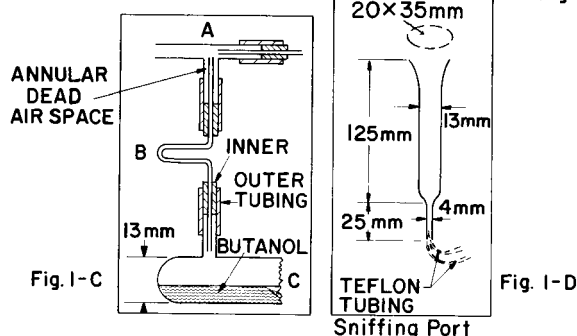

Fig. 1-C

Fig. 1-D

FIG. X1.1 Butanol Scale Olfactometer