**Geotechnical investigation and
testing — Field testing —**

**Part 4:
Prebored pressuremeter test by
Ménard procedure**

iTeh STANDARD PREVIEW
*Reconnaissance et essais géotechniques — Essais en place —
Partie 4: Essai pressiométrique dans un forage préalable selon la
procédure Ménard*
(standards.iteh.ai)

[ISO 22476-4:2021](https://standards.iteh.ai/catalog/standards/sist/d9d1cd96-5c08-48cc-a27a-9c9248146fac/iso-22476-4-2021)

<https://standards.iteh.ai/catalog/standards/sist/d9d1cd96-5c08-48cc-a27a-9c9248146fac/iso-22476-4-2021>



iTeh STANDARD PREVIEW
(standards.iteh.ai)

ISO 22476-4:2021

<https://standards.iteh.ai/catalog/standards/sist/d9d1cd96-5c08-48cc-a27a-9c9248146fac/iso-22476-4-2021>



COPYRIGHT PROTECTED DOCUMENT

© ISO 2021

All rights reserved. Unless otherwise specified, or required in the context of its implementation, no part of this publication may be reproduced or utilized otherwise in any form or by any means, electronic or mechanical, including photocopying, or posting on the internet or an intranet, without prior written permission. Permission can be requested from either ISO at the address below or ISO's member body in the country of the requester.

ISO copyright office
CP 401 • Ch. de Blandonnet 8
CH-1214 Vernier, Geneva
Phone: +41 22 749 01 11
Email: copyright@iso.org
Website: www.iso.org

Published in Switzerland

Contents

	Page
Foreword	v
Introduction	vi
1 Scope	1
2 Normative references	1
3 Terms, definitions and symbols	1
3.1 Terms and definitions.....	1
3.2 Symbols.....	3
4 Equipment	6
4.1 General description.....	6
4.2 Pressuremeter probe.....	6
4.2.1 General.....	6
4.2.2 Probe with flexible cover.....	8
4.2.3 Probe with flexible cover and an additional more rigid protection.....	8
4.2.4 Probe with flexible cover and slotted tube.....	9
4.3 Connecting lines and injected fluid.....	10
4.4 Pressure and volume control unit.....	11
4.4.1 General.....	11
4.4.2 Measurement and control.....	11
4.4.3 Data logger.....	12
5 Test procedure	12
5.1 Assembling the parts.....	12
5.2 Calibration and corrections.....	13
5.3 Pressuremeter test pocket and probe placing.....	13
5.4 Preparation for testing.....	13
5.5 Establishing the loading programme.....	14
5.6 Establishing the pressure of the guard cells for tri-cell probes.....	15
5.7 Expansion.....	15
5.7.1 General.....	15
5.7.2 Readings and recordings.....	15
5.7.3 End of test.....	16
5.8 Back-filling of the pockets.....	16
5.9 Safety requirements.....	16
6 Test results	16
6.1 Data sheet and field print-out or display.....	16
6.1.1 Data sheet for type A control unit.....	16
6.1.2 Site print-out for type B and C control units.....	17
6.1.3 Raw pressuremeter curve.....	17
6.2 Corrected pressuremeter curve.....	17
6.3 Calculated results.....	18
7 Reporting	19
7.1 General.....	19
7.2 Field report.....	19
7.3 Test report.....	19
7.3.1 General.....	19
7.3.2 Ménard pressuremeter test report.....	19
7.3.3 Pressuremeter tests log.....	20
Annex A (normative) Geometrical features of pressuremeter probes	22
Annex B (normative) Calibration and corrections	24
Annex C (normative) Placing the pressuremeter probe in the ground	33
Annex D (normative) Obtaining pressuremeter parameters	41

Annex E (normative) Uncertainties	51
Annex F (informative) Pressuremeter test records	53
Bibliography	60

iTeh STANDARD PREVIEW
(standards.iteh.ai)

[ISO 22476-4:2021](https://standards.iteh.ai/catalog/standards/sist/d9d1cd96-5c08-48cc-a27a-9c9248146fac/iso-22476-4-2021)

<https://standards.iteh.ai/catalog/standards/sist/d9d1cd96-5c08-48cc-a27a-9c9248146fac/iso-22476-4-2021>

Foreword

ISO (the International Organization for Standardization) is a worldwide federation of national standards bodies (ISO member bodies). The work of preparing International Standards is normally carried out through ISO technical committees. Each member body interested in a subject for which a technical committee has been established has the right to be represented on that committee. International organizations, governmental and non-governmental, in liaison with ISO, also take part in the work. ISO collaborates closely with the International Electrotechnical Commission (IEC) on all matters of electrotechnical standardization.

The procedures used to develop this document and those intended for its further maintenance are described in the ISO/IEC Directives, Part 1. In particular, the different approval criteria needed for the different types of ISO documents should be noted. This document was drafted in accordance with the editorial rules of the ISO/IEC Directives, Part 2 (see www.iso.org/directives).

Attention is drawn to the possibility that some of the elements of this document may be the subject of patent rights. ISO shall not be held responsible for identifying any or all such patent rights. Details of any patent rights identified during the development of the document will be in the Introduction and/or on the ISO list of patent declarations received (see www.iso.org/patents).

Any trade name used in this document is information given for the convenience of users and does not constitute an endorsement.

For an explanation of the voluntary nature of standards, the meaning of ISO specific terms and expressions related to conformity assessment, as well as information about ISO's adherence to the World Trade Organization (WTO) principles in the Technical Barriers to Trade (TBT), see www.iso.org/iso/foreword.html.

This document was prepared by Technical Committee ISO/TC 182, *Geotechnics*, in collaboration with the European Committee for Standardization (CEN) Technical Committee CEN/TC 341, *Geotechnical Investigation and Testing*, in accordance with the Agreement on technical cooperation between ISO and CEN (Vienna Agreement).

This second edition cancels and replaces the first edition (ISO 22476-4:2012), which has been technically revised.

The main changes compared to the previous edition are as follows:

- types of probes;
- correction procedures;
- probe placing techniques in [Annex C](#);
- clarification of D;
- harmonization of terms and symbols.

A list of all parts in the ISO 22476 series can be found on the ISO website.

Any feedback or questions on this document should be directed to the user's national standards body. A complete listing of these bodies can be found at www.iso.org/members.html.

Introduction

The Ménard pressuremeter test is performed by the radial expansion of a cylindrical probe of a minimum slenderness of 6, placed in the ground (see Figure 1). During the injection of the fluid volume in the probe, the inflation of the measuring cell first brings the outer cover of the probe into contact with the pocket wall and then producing ground displacement. Pressure applied to and the associated radial expansion of the probe are measured either by volume or radial transducers and recorded so as to obtain the stress-strain relationship of ground as tested.

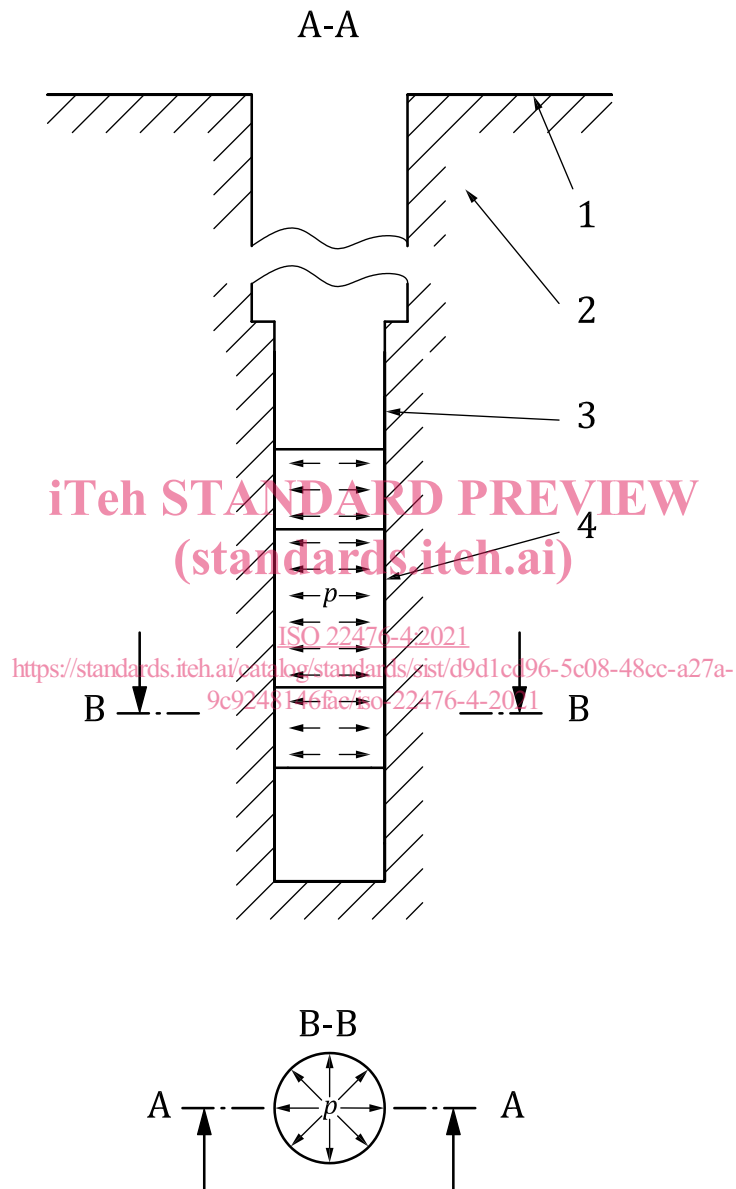

Figure 1 — Principle of a Ménard pressuremeter test

Together with results of investigations with ISO 22475-1 being available or at least with identification and description of the ground according to ISO 14688-1 and ISO 14689 obtained during the pressuremeter

test operations, the tests are performed in order to obtain the quantitative determination of a ground profile, including

- the Ménard pressuremeter modulus E_M ,
- the Ménard pressuremeter limit pressure p_{1M} , and
- the Ménard creep pressure p_f .

NOTE 1 This document fulfils the requirement for the Ménard pressuremeter test, as part of geotechnical investigation and testing according to EN 1997-1 and EN 1997-2.

NOTE 2 This document refers to a probe historically described as the “60 mm (also called BX) G type probe”, that corresponds to a 58 mm diameter probe with a drilling diameter between 60 mm and 66 mm with a pressure limitation of 5 MPa. If specified by the relevant authority or agreed for a specific project by the relevant parties, a different pressure, not higher than 8 MPa, can be set.

NOTE 3 G type probe refers to probes with an external cover creating guard cells (see 4.2).

NOTE 4 Ménard pressuremeter tests can be carried out with other diameter probes such as 32 mm, 44 mm and 76 mm probes.

NOTE 5 Examples of other probe and pocket drilling dimensions are indicated in Table 1.

Table 1 — Probe and pocket drilling dimensions

Probe Designation	Probe Diameter mm	Drilling diameter (mm)	
		Min	Max
AX	44	46	52
NX	70/74	74	80

NOTE 6 Tests with maximum pressures higher than 8 MPa are dealt by ISO 22476-5.

NOTE 7 For the scope of this document (and the associated measuring device and maximum uncertainties given in Table E.1), E_M values up to 500 MPa (that can be determined by calculation) can be commonly obtained. Enhancement of equipment to reduce uncertainties can be implemented to increase the range of measurements. For example, use of GA type equipment and of a shunt for volume measurement can allow measuring E_M values up to 10 000 MPa. Uncertainty calculation can be used to confirm the relevance of these pressuremeter moduli.

iTeh STANDARD PREVIEW
(standards.iteh.ai)

ISO 22476-4:2021

<https://standards.iteh.ai/catalog/standards/sist/d9d1cd96-5c08-48cc-a27a-9c9248146fac/iso-22476-4-2021>

Geotechnical investigation and testing — Field testing —

Part 4:

Prebored pressuremeter test by Ménard procedure

1 Scope

This document specifies equipment requirements, the execution of and reporting on the Ménard pressuremeter test.

This document describes the procedure for conducting a Ménard pressuremeter test in natural grounds, treated or untreated fills, either on land or off-shore.

The pressuremeter tests results of this document are suited to a quantitative determination of ground strength and deformation parameters. They can yield lithological information in conjunction with measuring while drilling performed when creating the borehole (according to ISO 22476-15). They can also be combined with direct investigation (e.g. sampling according to ISO 22475-1) or compared with other in situ tests (see EN 1997-2).

2 Normative references

The following documents are referred to in the text in such a way that some or all of their content constitutes requirements of this document. For dated references, only the edition cited applies. For undated references, the latest edition of the referenced document (including any amendments) applies.

ISO 14688-1, *Geotechnical investigation and testing — Identification and classification of soil — Part 1: Identification and description*

ISO 14689, *Geotechnical investigation and testing — Identification, description and classification of rock*

ISO 22475-1, *Geotechnical investigation and testing – Sampling by drilling and excavation and ground water measurements – Part 1: Technical principles for execution*

ISO 22476-15, *Geotechnical investigation and testing — Field testing — Part 15: Measuring while drilling*

3 Terms, definitions and symbols

3.1 Terms and definitions

For the purposes of this document, the following terms and definitions apply:

ISO and IEC maintain terminological databases for use in standardization at the following addresses:

— ISO Online browsing platform: available at <https://www.iso.org/obp>

— IEC Electropedia: available at <https://www.electropedia.org/>

3.1.1

pressuremeter probe

cylindrical flexible probe which can be expanded by the application of hydraulic pressure and/or pressurised gas

3.1.2

pressuremeter control unit

set of suitable devices capable of supplying fluid and/or gas pressure to the probe, to adjust pressure steps and take readings of the probe's pressure and the volume or radius of the measuring cell

3.1.3

connecting line

cable that connects the control unit to the probe, delivers fluid and/or gas pressure in the measuring and guard cells

3.1.4

pressuremeter test pocket

circular cylindrical cavity formed in the ground to receive a *pressuremeter probe* (3.1.1)

Note 1 to entry: See [Annex C](#).

3.1.5

pressuremeter borehole

borehole in which *pressuremeter test pockets* (3.1.4) with circular cross sections are made in the ground, and into which the *pressuremeter probe* (3.1.1) is to be placed

Note 1 to entry: See [Figure 1](#).

3.1.6

Ménard pressuremeter test

process during which a *pressuremeter probe* (3.1.1) is inflated in the *pressuremeter test pocket* (3.1.4) and the resulting pocket expansion is measured as a function of time and pressure increments according to a defined programme

Note 1 to entry: See [Figure 4](#).

3.1.7

pressuremeter sounding

sequence of *Ménard pressuremeter tests* (3.1.6) executed from the same station in the *pressuremeter borehole* (3.1.5)

3.1.8

pressure reading

pressure as read at the control unit (CU) elevation in the fluid and/or gas circuit supplying the measuring cell

3.1.9

pressure loss

difference between the pressure inside the probe and the pressure applied to the *pressuremeter test pocket* (3.1.4) wall

3.1.10

volume loss

volume readings on the control unit while probe is kept at constant external diameter

Note 1 to entry: They are due to system compressibility (including membrane, probe, tubing, fluid and control unit).

3.1.11

raw pressuremeter curve

graphical plot of the injected volumes recorded at time 60 s, noted V_{60} , versus the applied pressure at each pressure step, p_T

3.1.12**corrected pressuremeter curve**

graphical plot of the corrected volumes V_i or radial displacements versus the corrected pressure p

Note 1 to entry: See [Figure 5](#).

3.1.13**pressuremeter creep**

difference in volumes recorded at 60 s and at 30 s at each pressure step: $V_{60} - V_{30} = V_{60/30}$

3.1.14**corrected pressuremeter creep curve**

graphical plot of the corrected pressuremeter creep, versus the corrected applied pressure at each pressure step

Note 1 to entry: See [Figure 5](#).

3.1.15**pressuremeter log**

graphical report of the results of the *pressuremeter sounding* ([3.1.7](#)), together with all the information gathered during the drilling

Note 1 to entry: See [E.3](#).

3.1.16**Ménard pressuremeter modulus**

modulus obtained from the section between (p_1, V_1) and (p_2, V_2) of the pressuremeter curve

Note 1 to entry: See [Figure D.6](#).

3.1.17**Ménard pressuremeter limit pressure**

pressure at which the volume of the *pressuremeter test pocket* ([3.1.4](#)) at the depth of the measuring cell has doubled its original volume

Note 1 to entry: See [Figure D.5](#).

3.1.18**pressuremeter creep pressure**

pressure defined as the intersection of two straight lines fitted on the creep curve

Note 1 to entry: See [Figure D.4](#).

3.1.19**operator**

person who carries out the test

3.1.20**casing**

lengths of tubing inserted into a borehole to prevent the hole caving in or to prevent the loss of flushing medium to the surrounding formation, above pocket location

3.2 Symbols

For the purposes of this document, the symbols in [Table 2](#) apply:

Table 2 — Symbols

Symbol	Description	Unit
A, B	Parameters for reciprocal curve fitting method	$\text{cm}^3, \text{cm}^3/\text{MPa}$

Table 2 (continued)

Symbol	Description	Unit
A_1 to A_6	Parameters for hyperbolic curve fitting methods	variable
a	Apparatus volume loss coefficient	cm ³ /MPa
b, c	Parameters of power law type interpolation for the probe pressure loss correction	variable
d, e	Parameters of linear type interpolation for the probe volume loss correction	variable
d_c	Outside diameter of the central measuring cell, including any additional protection such as a slotted tube	mm
d_{ci}	Outside diameter of the inner part of the probe with slotted tube	mm
d_g	Outside diameter of the guard cells	mm
d_i	Inside diameter of the calibration cylinder used for the volume loss calibration	mm
d_r	Outside diameter of the central measuring cell during expansion as read on the CU, before data correction	cm ³
d_t	Drilling tool diameter	mm
E_M	Ménard pressuremeter modulus	MPa
K	Factor to determine the differential pressure for tri-cell probes	-
l_c	Length of the central measuring cell of the probe, when the cell membrane is fixed on the probe steel core	mm
l_g	Length of each guard cell	mm
l_m	Length along the tube axis of the slotted section of the slotted tube	mm
l_p	Length of the calibration cylinder used for the volume loss calibration	mm
l_t	Length of the cover	mm
m	Parameter of power law type interpolation for the probe pressure loss correction	-
m_E	Minimum value, strictly positive, of the m_i slopes	cm ³ /MPa
m_i	Slope of the corrected pressuremeter curve between the two points with coordinates (p_{i-1}, V_{i-1}) and (p_i, V_i)	cm ³ /MPa
p	Pressure applied to the ground after correction	MPa
p_c	Fluid or gas pressure in the measuring cell of the pressuremeter probe.	MPa
p_e	Correction for probe pressure loss	MPa
p_E	Pressure at the origin of the segment exhibiting the slope m_E	MPa
p'_E	Pressure at the end of the segment exhibiting the slope m_E	MPa
p_{el}	Ultimate pressure loss of the probe	MPa
p_f	Pressuremeter creep pressure	MPa
p_g	Pressure in the guard cells, read at the CU transducer elevation	-
p_h	Hydrostatic pressure between the control unit indicator and the central measuring cell of the pressuremeter probe	MPa
p_i	Pressuremeter corrected pressure	MPa
p_{IM}	Ménard pressuremeter limit pressure of the ground	MPa
p_{IMDH}	Ménard pressuremeter limit pressure as extrapolated by the double hyperbolic method	MPa
p_{IMH}	Ménard pressuremeter limit pressure as extrapolated by the hyperbolic method	MPa
p_{IMR}	Ménard pressuremeter limit pressure as extrapolated by the reciprocal curve method	MPa
p_m	Pressure loss of the central measuring cell membrane for a specific expansion	MPa
p_r	Pressure in the measuring cell fluid or gas circuit, read at the CU transducer elevation	MPa
p_t	Target pressure for each pressure step according to loading program	MPa

Table 2 (continued)

Symbol	Description	Unit
p_0	Pressuremeter horizontal at rest pressure	MPa
p_1	Corrected pressure at the origin of the pressuremeter modulus pressure range	MPa
p_2	Corrected pressure at the end of the pressuremeter modulus pressure range	MPa
t	Time	s
t_h	Time the loading pressure level is held	s
u_s	Pore water pressure in the ground at the depth of the test	MPa
V	Value, after zeroing and data correction, of the volume injected in the central measuring cell and measured 60 s after starting a pressure step	cm ³
V_c	Original volume of the central measuring cell, including the slotted tube, if applicable	cm ³
V_E	Value, after data correction, of the volume injected in the central measuring cell for pressure p_E	cm ³
V'_E	Value, after data correction, of the volume injected in the central measuring cell for pressure p'_E	cm ³
V_e	Correction for volume loss of the whole equipment	
V_i	Corrected volume	cm ³
V_L	Value, after data correction, of the volume injected in the central measuring cell when the original volume of the pressuremeter cavity has doubled	cm ³
V_m	The average corrected volume between V_1 and V_2	cm ³
V_p	Volume corresponding is the intercept on the volume axis of the straight line best fitting the data points on the p - V curve obtained in the volume loss calibration test (see Figure B.2)	cm ³
V_r	Volume injected in the probe as read on the CU, before data correction	cm ³
V_t	Volume of the central measuring cell including the slotted tube	cm ³
V_1	Corrected volume at the origin of the pressuremeter modulus pressure range	cm ³
V_2	Corrected volume at the end of the pressuremeter modulus pressure range	cm ³
V_{30}	Volume injected in the central measuring cell as read 30 s after the beginning of the pressure step	cm ³
V_{60}	Volume injected in the central measuring cell as read 60 s after the beginning of the pressure step	cm ³
$V_{60/30}$	Injected volume change from 30 s to 60 s after reaching the pressure step, also called pressuremeter creep	cm ³
$V_{60/60}$	60 s injected volume change between two successive pressure steps	cm ³
z	Elevation, positively counted above datum	m
z_{CU}	Elevation of the pressure measuring device for the fluid and/or gas injected in the probe	m
z_N	Elevation of the ground surface at the location of the pressuremeter sounding	m
z_p	Elevation of the measuring cell centre during testing	m
z_w	Elevation of the ground water table (or free water surface in a marine or river environment)	m
β	Coefficient used to determine the pressuremeter modulus pressure range	---
γ	Unit weight of ground at the time of testing	kN/m ³
γ_i	Unit weight of the liquid injected in the central measuring cell	kN/m ³
γ_w	Unit weight of water	kN/m ³
Δp	Loading pressure increment	MPa
Δp_1	Initial pressure increment	MPa
r_i	Radius of the measuring cell for transducer i	m

Table 2 (continued)

Symbol	Description	Unit
Δt_i	Duration to achieve pressure step i	s
δV	Tolerance for volume measurement	cm ³
λ_g	Rate of change of pressure head of gas at p_k per metre depth	m ⁻¹
ν	Poisson's ratio	-
σ_{hs}	Total horizontal stress in the ground at test elevation	kPa
σ_{vs}	Total vertical stress in the ground at test depth	kPa

4 Equipment

4.1 General description

The pressuremeter shown schematically in [Figure 2](#) shall include:

- the pressuremeter probe;
- the string of rods to handle the probe;
- the control unit (CU);
- the connecting lines between the control unit and the probe.

Some means of measuring the depth of the test with appropriate measurement error shall be provided (see also [Annex E](#)).

4.2 Pressuremeter probe

ISO 22476-4:2021

<https://standards.iteh.ai/catalog/standards/sist/d9d1cd96-5c08-48cc-a27a-9c9248146fac/iso-22476-4-2021>

4.2.1 General

The probe shall be made up of cylindrical cells of circular cross-section along the same axis (see [Figure 2](#)). The probe shall consist of a hollow steel core with passages to inject the proper fluids to inflate the cells. The steel core, on its outside curved surface, shall usually bear a network of grooves which uniformly distribute the liquid (if relevant) in the measuring cell under the membrane, applying a uniform pressure on the pressuremeter test pocket wall. The top of the core shall be threaded and coupled to the string of rods handling the probe from ground level.

If the measuring cell has slenderness at least equal to 6, the probe may be mono-cell. Conversely the probe may be tri-cell to respect this criterion. A central measuring cell membrane shall isolate the fluid in the central measuring cell from the gas of the guard cells.

NOTE 1 Compliance with this criterion ensures that the stress field is two-dimensional.

The central measuring cell may be:

- covered by the cover creating guard cell (tri-cell G type probe);
- covered by the cover with specific membranes for guard cells (tri-cell E type probe);
- covered by the cover without guard cells (mono-cell type).

All probes can be equipped for volumetric measurement or by radial transducer or any device providing a reliable measure of either probe volume or radius. Pressure can be measured at control unit level or at probe level.

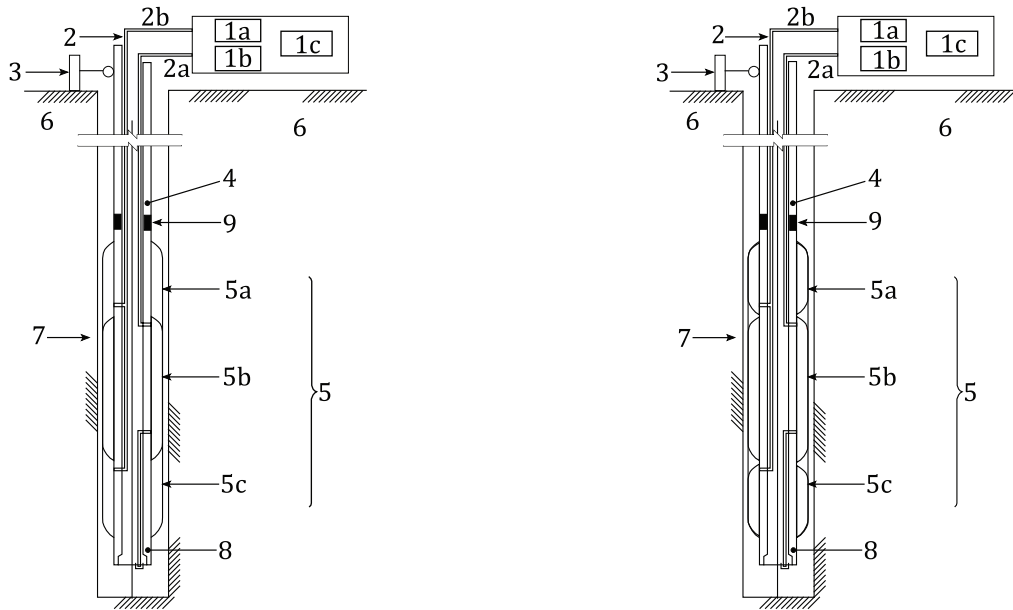

a) Tri-cell probe, G type, with measurement of volume of the measuring cell

b) Tri-cell probe, E type, with measurement of volume of the measuring cell

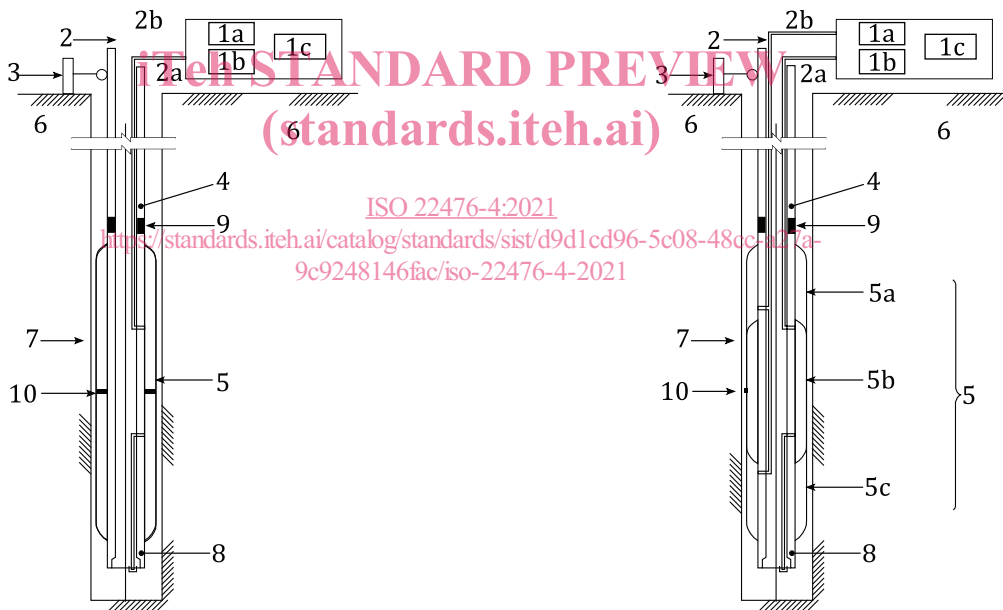

c) Mono-cell probe, with measurement of radial displacement (optional)

d) Tri-cell probe, with measurement of radial displacement

Key

- 1a pressurization, differential pressurization and injection devices
- 1b pressure and volume measuring devices
- 1c acquisition, storage and printing out of the data (required for CU type B and C)
- 2 connecting lines:
 - 2a line for liquid injection
 - 2b line for gas injection
- 3 depth measurement system
- 4 rods
- 5 pressuremeter probe
- 6 ground
- 7 pressuremeter test pocket
- 8 hollow probe body