

~~ISO/TC 182~~

~~Date: 2022-10-24~~

~~ISO/DIS~~DIS 22476-5:2022(E)

~~Date: 2022-12-07~~

~~ISO/TC 182/WG 08~~TC 182/WG 08

Secretariat: BSI

**Geotechnical investigation and testing — Field testing — Part 5: Prebored
pressuremeter test**

*Reconnaissance et essais géotechniques — Essais en place — Partie 5: Essai au pressiomètre en
préforage*

iTeh STANDARD PREVIEW
(standards.iteh.ai)

ISO 22476-5

<https://standards.iteh.ai/catalog/standards/sist/e6a5fd96-26dd-48ff-89e0-9ebbb799434a/iso-22476-5>

Edited DIS - MUST BE USED FOR FINAL DRAFT

Error! Reference source not found.

COPYRIGHT PROTECTED DOCUMENT

All rights reserved. Unless otherwise specified, no part of this publication may be reproduced or utilized otherwise in any form or by any means, electronic or mechanical, including photocopying, or posting on the internet or an intranet, without prior written permission. Permission can be requested from either ISO at the address below or ISO's member body in the country of the requester.

ISO copyright office

Ch. de Blandonnet 8 • CP 401

CH-1214 Vernier, Geneva, Switzerland

Tel. + 41 22 749 01 11

Fax + 41 22 749 09 47

copyright@iso.org

www.iso.org

iTeh STANDARD PREVIEW
(standards.iteh.ai)

ISO 22476-5

<https://standards.iteh.ai/catalog/standards/sist/e6a5fd96-26dd-48ff-89e0-9ebbb799434a/iso-22476-5>

Contents

Foreword.....	viii
1 — Scope.....	1
2 — Normative references	1
3 — Terms, definitions and symbols.....	2
3.1 — Terms and definitions.....	2
Figure 1 — Example of a prebored pressuremeter test.....	5
3.2 — Symbols and abbreviations.....	6
Table 1 — Symbols.....	6
4 — Equipment	8
4.1 — General.....	8
Figure 2 — Schematic diagram of pressuremeter equipment.....	10
Figure 3 — Sketch of pressuremeter probes	11
4.2 — Pressuremeter probe	12
4.3 — Connecting lines.....	12
4.4 — Control unit (CU).....	12
Table 2 — Types of pressuremeter control unit	13
4.5 — Measurement and control accuracy.....	13
4.5.1 — Time	13
4.5.2 — Pressure and expansion	13
4.5.3 — Display of readings.....	13
4.5.4 — Expansion calibration cylinder	13
5 — Test procedures	13
5.1 — Assembly of parts	13
5.2 — Calibration of the testing device and corrections of readings	13
5.3 — Pressuremeter test pocket and probe placing.....	14
5.4 — Test execution	14
5.4.1 — Test loading programmes.....	14
5.4.2 — Reference loading programmes	15
Figure 4 — Reference loading programmes A, B, C and D.....	15
5.4.3 — Readings and recordings before and during the test.....	16
5.5 — End of test	16
5.6 — Backfilling of borehole.....	17
5.7 — Safety requirements.....	17
6 — Test results	17
6.1 — General.....	17
6.2 — Corrected pressure, radial displacement and volume	17
6.3 — Apparent pressuremeter moduli	18
6.4 — Results.....	18
6.4.1 — Determination of moduli	18
6.4.2 — Reference loading programme A.....	19
Table 3 — Pressuremeter shear moduli for reference loading programme A.....	19

Figure 5 — Prebored pressuremeter shear moduli G_{PPB} in reference procedure A	20
6.4.3 — Reference loading programme B	20
Table 4 — Pressuremeter shear moduli for reference loading programme B	20
Figure 6 — Prebored pressuremeter Shear moduli G_{PPB} in reference procedure B	21
6.4.4 — Reference loading programme C	22
Figure 7 — Obtention of the creep parameter k_t in the reference loading programme C	23
7 — Test report	Error! Bookmark not defined.
7.1 — General	23
7.2 — Reporting	Error! Bookmark not defined.
7.3 — Presentation of test results	25
Annex A (normative) Calibration and corrections	26
A.1 — Measuring devices	26
A.2 — Pressure correction	26
A.2.1 — Preparation of pressuremeter for membrane pressure loss calibration	26
A.2.2 — Membrane pressure loss calibration	26
Figure A.1 — Membrane stiffness calibration, a) with radial displacement measurement, b) with injected volume measurement	27
A.3 — Displacement or volume correction	27
A.3.1 — General	27
A.3.2 — Calibration cylinder(s)	28
A.3.3 — Calibration in the general case	28
A.3.3.1 Calibration including one single cylinder	28
Figure A.2 — Determination of the combined correction for membrane compression and connecting lines dilatation (if relevant)	30
A.3.3.2 Calibration including several cylinders	30
Figure A.3 — Set of expansion calibration curves	31
Figure A.4 — Determination of cavity radial displacement when using several calibration cylinders (example when probe expansion is followed through its volume)	32
A.3.4 — Additional calibration in case of unloading-reloading loops	32
Figure A.5 — Determination of the apparent system stiffness G_{sys}	34
Figure A.6 — Determination of the apparent system stiffness G_{sys} as a function of the pressure at the beginning of the unloading-reloading loops	34
Annex B (normative) Performing the test	36
B.1 — Common elements to reference loading programmes A and B	36
B.2 — Details of reference loading programme A	36
Figure B.1 — Example of reference loading programme A	37
B.3 — Details of reference loading programme B	38
Figure B.2 — Example of reference loading programme B	39
B.4 — Details of reference loading programme C	39

Figure B.3 — Example of reference loading programme C	40
Figure B.4 — Corrected applied pressure in reference procedure C with pressure as controlling parameter.....	41
B.5 — Details of reference loading programme D.....	41
Figure B.5 — Reference loading programme D	42
Annex C (normative) Accuracy and uncertainties	43
C.1 — Uncertainties of the measurements	43
Table C.1 — Maximum allowed uncertainties.....	43
C.2 — Uncertainties of the tests results.....	43
Bibliography.....	45
Foreword.....	vii
1 Scope.....	1
2 Normative references	1
3 Terms, definitions and symbols.....	2
3.1 Terms and definitions.....	2
Figure 1 — Example of a prebored pressuremeter test.....	5
3.2 Symbols and abbreviations.....	6
Table 1 — Symbols.....	6
4 Equipment	8
4.1 General.....	8
Figure 2 — Schematic diagram of pressuremeter equipment.....	10
Figure 3 — Sketch of pressuremeter probes	11
4.2 Pressuremeter probe	12
4.3 Connecting lines.....	12
4.4 Control unit (CU).....	12
Table 2 — Types of pressuremeter control unit	13
4.5 Measurement and control accuracy	13
4.5.1 Time	13
4.5.2 Pressure and expansion	13
4.5.3 Display of readings.....	13
4.5.4 Expansion calibration cylinder.....	13
5 Test procedures	13
5.1 Assembly of parts	13
5.2 Calibration of the testing device and corrections of readings	13
5.3 Pressuremeter test pocket and probe placing.....	14
5.4 Test execution	14
5.4.1 Test loading programmes.....	14
5.4.2 Reference loading programmes	15
Figure 4 — Reference loading programmes A, B, C and D	15
5.4.3 Readings and recordings before and during the test.....	16
5.5 End of test	16
5.6 Backfilling of borehole.....	17
5.7 Safety requirements	17
6 Test results	17

6.1	General.....	17
6.2	Corrected pressure, radial displacement and volume.....	17
6.3	Apparent pressuremeter moduli.....	18
6.4	Results.....	18
6.4.1	Determination of moduli.....	18
6.4.2	Reference loading programme A.....	19
	Table 3 — Pressuremeter shear moduli for reference loading programme A.....	19
	Figure 5 — Prebored pressuremeter shear moduli G_{PPB} in reference procedure A.....	20
6.4.3	Reference loading programme B.....	20
	Table 4 — Pressuremeter shear moduli for reference loading programme B.....	20
	Figure 6 — Prebored pressuremeter shear moduli G_{PPB} in reference procedure B.....	21
6.4.4	Reference loading programme C.....	22
	Figure 7 — Obtention of the creep parameter k_t in the reference loading programme C.....	23
7	Reporting.....	23
7.1	General.....	23
7.2	Contents.....	23
	Table 5 — General information.....	23
7.3	Presentation of test results.....	25
	Annex A (normative) Calibration and corrections.....	26
A.1	Measuring devices.....	26
A.2	Pressure correction.....	26
A.2.1	Preparation of pressuremeter for membrane pressure loss calibration.....	26
A.2.2	Membrane pressure loss calibration.....	26
A.3	Displacement or volume correction.....	27
A.3.1	General.....	27
A.3.2	Calibration cylinder(s).....	28
A.3.3	Calibration in the general case.....	28
A.3.3.1	Calibration including one single cylinder.....	28
A.3.3.2	Calibration including several cylinders.....	30
A.3.4	Additional calibration in case of unloading-reloading loops.....	32
	Annex B (informative) Performing the test.....	36
B.1	Common elements to reference loading programmes A and B.....	36
B.2	Details of reference loading programme A.....	36
	Figure B.1 — Example of reference loading programme A.....	37
B.3	Details of reference loading programme B.....	38
	Figure B.2 — Example of reference loading programme B.....	39
B.4	Details of reference loading programme C.....	39
	Figure B.3 — Example of reference loading programme C.....	40
	Figure B.4 — Corrected applied pressure in reference procedure C with pressure as controlling parameter.....	41
B.5	Details of reference loading programme D.....	41
	Figure B.5 — Reference loading programme D.....	42

Annex C (normative) Accuracy and uncertainties	43
C.1 Uncertainties of the measurements	43
Table C.1 — Maximum allowed uncertainties	43
C.2 Uncertainties of the tests results	43
Bibliography	45

iTeh STANDARD PREVIEW
(standards.iteh.ai)

ISO 22476-5

<https://standards.iteh.ai/catalog/standards/sist/e6a5fd96-26dd-48ff-89e0-9ebbb799434a/iso-22476-5>

Foreword

ISO (the International Organization for Standardization) is a worldwide federation of national standards bodies (ISO member bodies). The work of preparing International Standards is normally carried out through ISO technical committees. Each member body interested in a subject for which a technical committee has been established has the right to be represented on that committee. International organizations, governmental and non-governmental, in liaison with ISO, also take part in the work. ISO collaborates closely with the International Electrotechnical Commission (IEC) on all matters of electrotechnical standardization.

The procedures used to develop this document and those intended for its further maintenance are described in the ISO/IEC Directives, Part 1. In particular, the different approval criteria needed for the different types of ISO documents should be noted. This document was drafted in accordance with the editorial rules of the ISO/IEC Directives, Part 2 (see www.iso.org/directives).

Attention is drawn to the possibility that some of the elements of this document may be the subject of patent rights. ISO shall not be held responsible for identifying any or all such patent rights. Details of any patent rights identified during the development of the document will be in the Introduction and/or on the ISO list of patent declarations received (see www.iso.org/patents).

Any trade name used in this document is information given for the convenience of users and does not constitute an endorsement.

For an explanation of the voluntary nature of standards, the meaning of ISO specific terms and expressions related to conformity assessment, as well as information about ISO's adherence to the World Trade Organization (WTO) principles in the Technical Barriers to Trade (TBT), see www.iso.org/iso/foreword.html.

This document was prepared by Technical Committee ISO/TC 182, *Geotechnics*, in collaboration with the European Committee for Standardization (CEN) Technical Committee CEN/TC 341, *Geotechnical Investigation and Testing*, in accordance with the Agreement on technical cooperation between ISO and CEN (Vienna Agreement).

This second edition cancels and replaces the first edition (ISO 22476-5:2012), which has been technically revised.

The main changes are as follows:

- the title of the part has been modified;
- a reference loading programme with cyclic loading has been added;
- calibration procedures have been developed.

A list of all parts in the ISO 22476 series can be found on the ISO website.

Any feedback or questions on this document should be directed to the user's national standards body. A complete listing of these bodies can be found at www.iso.org/members.html.

Geotechnical investigation and testing — Field testing — Part 5: Prebored pressuremeter test

Geotechnical investigation and testing — Field testing — Part 5: Prebored pressuremeter test

1 Scope

This document is applicable to pressuremeter tests using cylindrical flexible probes placed in pre-existent boreholes using testing procedures other than the Menard procedure.

Pressuremeter tests following the Menard procedure are provided in ISO 22476-4.

NOTE A high-pressure flexible pressuremeter probe which contains transducers for the measurement of radial displacements is also known as flexible dilatometer probe or high-pressure dilatometer probe.

This document applies to tests performed in any kind of grounds, starting from soils, treated or untreated fills, hard soils and soft rocks, up to hard and very hard rocks, either on land or offshore.

The parameters derived from this test can include stiffness, strength, initial in-situ stress state and consolidation properties.

2 Normative references

The following documents are referred to in the text in such a way that some or all of their content constitutes requirements of this document. For dated references, only the edition cited applies. For undated references, the latest edition of the referenced document (including any amendments) applies.

EN 16228-1, *Drilling and foundation equipment – safety – Part 1: Common requirements*

EN 16228-2, *Drilling and foundation equipment – safety – Part 2: Mobile drill rigs for civil and geotechnical engineering, quarrying and mining*

ISO 10012, *Measurement management systems — Requirements for measurement processes and measuring equipment*

ISO 14689, *Geotechnical investigation and testing — Identification, description and classification of rock*

ISO 22475-1, *Geotechnical investigation and testing — Sampling methods and groundwater measurements — Part 1: Technical principles for the sampling of soil, rock and groundwater*

ISO 22476-4, *Geotechnical investigation and testing — Field testing — Part 4: Prebored pressuremeter test by Ménard procedure*

3 Terms, definitions and symbols

3.1 Terms and definitions

For the purposes of this document, the following terms and definitions apply.

ISO and IEC maintain terminology databases for use in standardization at the following addresses:

- ISO Online browsing platform: available at <https://www.iso.org/obp>
- IEC Electropedia: available at <https://www.electropedia.org/>

3.1.1

pressuremeter probe

cylindrical flexible probe which can be expanded by the application of hydraulic pressure and/or pressurised gas

Note 1 to entry: Pressuremeter probes contains means of measurement of its radial displacements or volume.

3.1.2

flexible dilatometer probe

high-pressure dilatometer probe

high-pressure flexible pressuremeter probe which contains transducers for the measurement of radial displacements

3.1.3

pressuremeter control unit

set of suitable devices capable of supplying fluid and/or gas pressure to the probe, to control and take readings of the probe's pressure, radial displacements or volume of the measuring cell

3.1.4

connecting line

cable that connects the control unit to the probe, delivers fluid and/or gas pressure in the measuring and guard cells

3.1.5

pressuremeter test pocket

circular cylindrical cavity formed in the ground to receive a *pressuremeter probe* (3.1.1)

3.1.6

pressuremeter test

process of expanding the pressuremeter probe so as to pressurize the flexible membrane against the pocket wall and so measure pressure, radial displacements or volume as a function of time during the expansion test (see Figure 1).

Note 1 to entry: see See Figure-1.

3.1.7

pressuremeter sounding

series of pressuremeter tests in a borehole

3.1.8

seating pressure

pressure during the expansion of the pressuremeter at which the pressuremeter membrane contacts the pocket wall

3.1.9

controlling parameter

variable used to define the loading programme of the test according to a pre-determined programme and recorded in the control unit

Note 1 to entry: ~~this~~This variable can be the pressure, the radius displacement or the injected volume.

3.1.10

radial displacement

change in pressuremeter probe radius/diameter or in cavity wall displacement

3.1.11

pressuremeter curve

graphical plot of pressure versus the associated cavity wall displacement or measuring cell volume

3.1.12

pressuremeter shear modulus

G_{PBP}

shear modulus obtained from the pressuremeter curve

Note 1 to entry: See 6.3

iTeh STANDARD PREVIEW
(standards.iteh.ai)

ISO 22476-5

<https://standards.iteh.ai/catalog/standards/sist/e6a5fd96-26dd-48ff-89e0-9ebbb799434a/iso-22476-5>

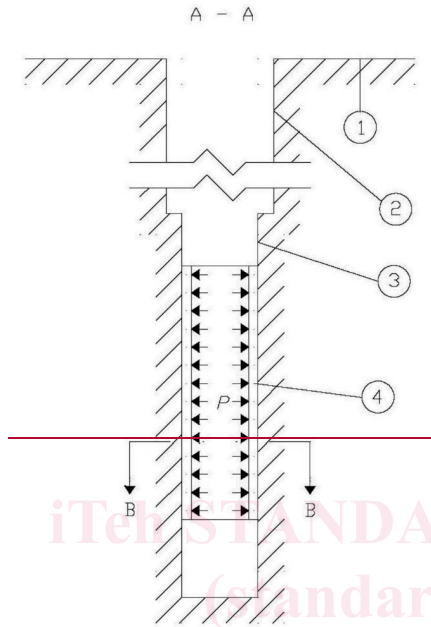

iTeh STANDARD PREVIEW
(standards.iteh.ai)

<https://standards.iteh.ai/standards/sist/e6a5fd96-26dd-48ff-89e0-9ebbb799434a/iso-22476-5> ISO 22476-5

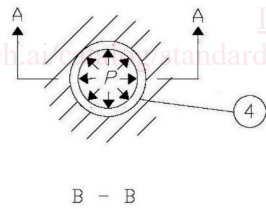

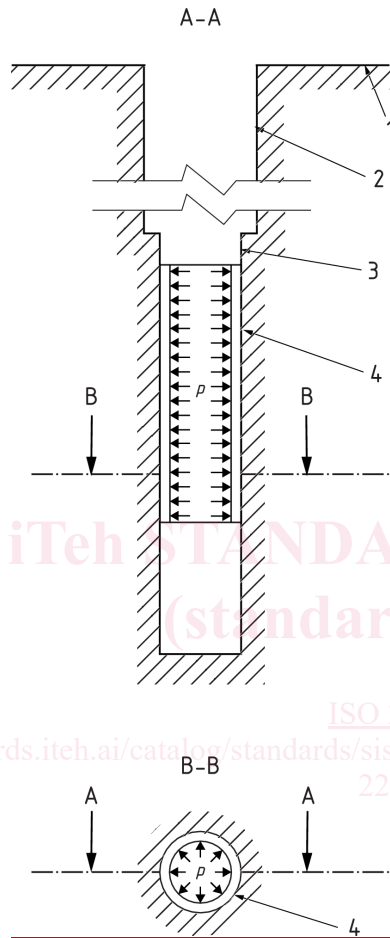

iTeh STANDARD PREVIEW
(standards.iteh.ai)

ISO 22476-5

<https://standards.iteh.ai/catalog/standards/sist/e6a5fd96-26dd-48ff-49e0-9ebbb799434a/iso-22476-5>

Key

- 1 ground surface
- 2 borehole wall
- 3 pocket
- 4 expanding pressuremeter probe
- p applied pressure
- A-A axial section
- B-B cross section

Figure 1 — Example of a prebored pressuremeter test

3.1.13

depth of test

distance between the ground level and the centre of the expanding length of the pressuremeter probe measured along the borehole axis

ISO/FDIS 22476-5:2022(E)

Note 1 to entry: -see See Figure 2.

3.1.14 operator

qualified person who carries out the test

3.1.15 phase

section of the loading or expansion program characterized by a controlling parameter, a loading rate and a loading direction

3.1.16 loop

sequence of the loading or expansion program including at least an unloading phase and a reloading phase, and possibly an intermediate hold phase

3.2 Symbols and abbreviations

For the purposes of this document, the symbols **of in** Table 1 apply.

Table 1 — Symbols

Symbol	Description	Unit
a	Corrected equipment radial displacement or volume loss coefficient, taking into account calibration cylinder self-deformability	mm.MPa ⁻¹ or cm ³ .MPa ⁻¹
a_r	Raw equipment radial displacement or volume loss coefficient	mm.MPa ⁻¹ or cm ³ .MPa ⁻¹
a_{cc}	Radial displacement or equivalent volume loss taking into account calibration cylinder self-deformability	mm.MPa ⁻¹ or cm ³ .MPa ⁻¹
d_{cc}	Calibration cylinder inside diameter	mm
d_c	Initial external diameter of the pressuremeter probe	mm
E_{PBP}	A Young modulus derived from a prebored pressuremeter test	MPa
G	Shear modulus	MPa
G_{L1}	First loading pressuremeter shear modulus	MPa
G_{PBP}	Pressuremeter shear modulus	MPa
G_{Ri}	A reloading pressuremeter shear modulus	MPa
G_{sys}	Apparent shear modulus of the equipment or system during unloading-reloading loops	MPa
G_{Ui}	An unloading pressuremeter shear modulus	MPa
G_{URi}	An unloading/reloading pressuremeter shear modulus	MPa
k_f	Creep parameter in reference loading programme C	mm
L_{FD}	Expanding length of the pressuremeter probe	mm

Symbol	Description	Unit
p	Corrected pressure	MPa
$p_{1.1}$	Constant full relief pressure for loops in reference loading programme A	MPa
p_e	Pressure loss associated with membrane stiffness	
p_i	Corrected reversal pressure before loop i	MPa
p_{mean}	Average corrected pressure in reference loading programme D	MPa
p_{min}	Minimum corrected pressure in reference loading programme D	MPa
p_{max}	Maximum corrected pressure in reference loading programme D	MPa
p_r	Pressure as read at the measuring unit	MPa
p_s	Seating pressure	MPa
r	Corrected radius	mm
r_1	Corrected radius at time t_1 in reference loading programme C	mm
r_2	Corrected radius at time t_2 in reference loading programme C	mm
r_e	Radius correction	-mm
r_s	Nominal cavity radius	mm
t	Time	min
T	Period in reference loading programme D	min
t_1	Time 1 in reference loading programme C	min
t_2	Time 2 in reference loading programme C	min
ΔV	Corrected injected volume	cm ³
ΔV_e	Injected volume correction	cm ³
ΔV_r	Injected volume, as read at the control unit	cm ³
V	Total volume	cm ³
z	Test depth	m
δ	Corrected radial displacement	mm
δ_e	Radial displacement correction	mm
δ_r	Radial displacement, as read at the control unit	mm
δ_s	Radial displacement corresponding to the seating pressure	mm
Δd_r	Increase of diameter, as read at the control unit	mm
Δd	Corrected diameter increase	mm
Δp_r	Pressure increment, as read at the control unit	MPa
Δp	Corrected pressure increment	MPa