



**iTeh STANDARD PREVIEW**  
**(standards.iteh.ai)**

SIST ISO 3548-2:2021

<https://standards.iteh.ai/catalog/standards/sist/dce81f18-6ffb-4b3b-96aa-fc410e5cb3ff/sist-iso-3548-2-2021>

INTERNATIONAL  
STANDARD

ISO  
3548-2

Second edition  
2020-09

---

---

**Plain bearings — Thin-walled half  
bearings with or without flange —  
Part 2:  
Measurement of wall thickness and  
flange thickness**

**iTeh STANDARD PREVIEW  
(standards.iteh.ai)**

[SIST ISO 3548-2:2021](https://standards.iteh.ai/catalog/standards/sist/dce81f18-6ffb-4b3b-96aa-fc410e5cb3ff/sist-iso-3548-2-2021)

<https://standards.iteh.ai/catalog/standards/sist/dce81f18-6ffb-4b3b-96aa-fc410e5cb3ff/sist-iso-3548-2-2021>



Reference number  
ISO 3548-2:2020(E)

© ISO 2020

## iTeh STANDARD PREVIEW (standards.iteh.ai)

SIST ISO 3548-2:2021

<https://standards.iteh.ai/catalog/standards/sist/dce81f18-6ffb-4b3b-96aa-fc410e5cb3ff/sist-iso-3548-2-2021>



### **COPYRIGHT PROTECTED DOCUMENT**

© ISO 2020

All rights reserved. Unless otherwise specified, or required in the context of its implementation, no part of this publication may be reproduced or utilized otherwise in any form or by any means, electronic or mechanical, including photocopying, or posting on the internet or an intranet, without prior written permission. Permission can be requested from either ISO at the address below or ISO's member body in the country of the requester.

ISO copyright office  
CP 401 • Ch. de Blandonnet 8  
CH-1214 Vernier, Geneva  
Phone: +41 22 749 01 11  
Email: [copyright@iso.org](mailto:copyright@iso.org)  
Website: [www.iso.org](http://www.iso.org)

Published in Switzerland

# Contents

	Page
Foreword .....	iv
<b>1 Scope</b> .....	<b>1</b>
<b>2 Normative references</b> .....	<b>1</b>
<b>3 Terms and definition</b> .....	<b>1</b>
<b>4 Symbols and units</b> .....	<b>2</b>
<b>5 Purpose of checking</b> .....	<b>2</b>
<b>6 Checking methods</b> .....	<b>3</b>
6.1 Measuring principle of wall thickness .....	3
6.2 Line measurement around the circumference .....	3
6.3 Line measurement in axial direction .....	4
6.4 Point measurement .....	5
6.5 Grading of bearings .....	7
6.6 Eccentric bore .....	7
6.7 Measuring principle for flange thickness .....	7
6.8 Measuring point for flange thickness .....	7
<b>7 Requirements for measuring equipment and specimen for the contact method</b> .....	<b>8</b>
7.1 Tip-radius for measuring pin on the outside surface .....	8
7.2 Tip-radius for measuring pin on the inside surface .....	8
7.3 Measuring pin load .....	8
7.4 Set-up .....	8
7.5 Periodical control .....	8
7.6 Measurement failures on the inside and/or outside surface .....	9
<b>8 Checking of measuring equipment</b> .....	<b>9</b>
<b>Bibliography</b> .....	<b>10</b>

## ISO 3548-2:2020(E)

## Foreword

ISO (the International Organization for Standardization) is a worldwide federation of national standards bodies (ISO member bodies). The work of preparing International Standards is normally carried out through ISO technical committees. Each member body interested in a subject for which a technical committee has been established has the right to be represented on that committee. International organizations, governmental and non-governmental, in liaison with ISO, also take part in the work. ISO collaborates closely with the International Electrotechnical Commission (IEC) on all matters of electrotechnical standardization.

The procedures used to develop this document and those intended for its further maintenance are described in the ISO/IEC Directives, Part 1. In particular, the different approval criteria needed for the different types of ISO documents should be noted. This document was drafted in accordance with the editorial rules of the ISO/IEC Directives, Part 2 (see [www.iso.org/directives](http://www.iso.org/directives)).

Attention is drawn to the possibility that some of the elements of this document may be the subject of patent rights. ISO shall not be held responsible for identifying any or all such patent rights. Details of any patent rights identified during the development of the document will be in the Introduction and/or on the ISO list of patent declarations received (see [www.iso.org/patents](http://www.iso.org/patents)).

Any trade name used in this document is information given for the convenience of users and does not constitute an endorsement.

For an explanation of the voluntary nature of standards, the meaning of ISO specific terms and expressions related to conformity assessment, as well as information about ISO's adherence to the World Trade Organization (WTO) principles in the Technical Barriers to Trade (TBT) see [www.iso.org/iso/foreword.html](http://www.iso.org/iso/foreword.html).

This document was prepared by Technical Committee ISO/TC 123, *Plain Bearings*, Subcommittee SC 5, *Quality analysis and assurance*.

This second edition cancels and replaces the first edition (ISO 3548-2:2009), which has been technically revised. The main changes compared to the previous edition are as follows:

- the term “flange thickness” has been introduced in [Clause 3](#);
- [Table 1](#) has been updated;
- several figures have been revised;
- a new [Table 3](#) “Thin walled half bearings with flange — Distance to measuring position  $a_{ch}$ ” has been introduced.

A list of all parts in the ISO 3548 series can be found on the ISO website.

Any feedback or questions on this document should be directed to the user's national standards body. A complete listing of these bodies can be found at [www.iso.org/members.html](http://www.iso.org/members.html).

# Plain bearings — Thin-walled half bearings with or without flange —

## Part 2: Measurement of wall thickness and flange thickness

### 1 Scope

This document specifies in accordance with ISO 12301 the checking of the wall-thickness of thin-walled half bearings with or without flange and describes the necessary checking methods and measuring equipment.

It applies to a maximum bearing diameter of 150 mm. It can be applied to a bigger diameter, provided that there is an agreement between the supplier and the user.

### 2 Normative references

The following documents are referred to in the text in such a way that some or all of their content constitutes requirements of this document. For dated references, only the edition cited applies. For undated references, the latest edition of the referenced document (including any amendments) applies.

ISO 3548-1, *Plain bearings — Thin-walled half bearings with or without flange — Part 1: Tolerances, design features and methods of test*

SIST ISO 3548-2:2021

<https://standards.iteh.ai/catalog/standards/sist/dce81f18-6ffb-4b3b-96aa-fc410e5cb3ff/sist-iso-3548-2-2021>

### 3 Terms and definition

ISO and IEC maintain terminological databases for use in standardization at the following addresses:

- ISO Online browsing platform: available at <http://www.iso.org/obp>
- IEC Electropedia: available at <http://www.electropedia.org/>

For the purposes of this document, the following definitions apply:

#### 3.1 wall thickness

$s_3$

radial distance between the opposing measuring points at the inner and outer cylindrical surfaces

Note 1 to entry: See [Figure 1](#).

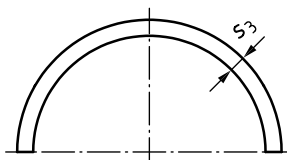

Figure 1 — Wall thickness,  $s_3$ , of a half bearing

## ISO 3548-2:2020(E)

## 3.2

**measuring point**

agreed point established to facilitate agreement on checking

Note 1 to entry: The establishment of measuring points (lines) does not preclude the need to comply with dimensional specifications in other areas.

## 3.3

**measuring line**

agreed line established to facilitate agreement on checking

Note 1 to entry: The establishment of measuring lines does not preclude the need to comply with dimensional specifications in other areas.

## 3.4

**tolerance**

range between the upper specified limit and the lower specified limit

## 3.5

**flange thickness**

axial distance between the opposing measuring points at the inside and the outside surface of flange

## 4 Symbols and units

For the purposes of this document, the symbols and units are those given in [Table 1](#).

**Table 1 — Symbols and units**

Symbol	Description	Unit
$a_{ch}$	distance to measuring position	mm
$a_9$	minimum height of transition	mm
$a_{ch,fl}$	radial distance to measuring position from flange outside edge	mm
$B$	width	mm
$B_{fl}$	flange width	mm
$C_i$	inner chamfer width	mm
$D_0$	nominal outside diameter	mm
$e_B$	eccentricity of bore centre to outside diameter centre	mm
$F_{pin}$	measuring pin load	N
$H$	distance to measuring position from bearing parting line	mm
$s_a$	wall thickness at angle $\alpha$	mm
$s_{fl}$	flange thickness	mm
$s_3$	wall thickness at crown	mm
$u$	wall thickness reduction at angle $\alpha_2$	mm
$x_1$	centre point of nominal outside diameter	—
$x_2$	centre point of eccentric bore	—
$\alpha$	angle to measuring position	°
$\alpha_2$	angle to measuring position from parting line	°
M1, M2	measuring line	—

## 5 Purpose of checking

In order to ensure the required bearing clearance, and consequently, the operational efficiency of the plain bearing unit, keep to the wall thickness tolerances specified in ISO 3548-1.



## 6 Checking methods

### 6.1 Measuring principle of wall thickness

The gauging axis of the measuring device shall be in the radial direction and perpendicular to the outside surface of the test piece in order to find the minimum value of the wall thickness. The measured values may be recorded by a single measurement or by sum measurement, which are symbolically represented in [Figure 2](#).



a) Single wall thickness measurement by contact (mechanical/electronic gauge)

b) Sum wall thickness measurement by contact/non-contact (electronic/pneumatic gauge)

Figure 2 — Methods for recording the measured value

**iTeh STANDARD PREVIEW**

The presence of lubricating holes, oil pockets, oil grooves, markings or special chamfers may require deviation from the measuring lines and measuring points specified in the following and shall be agreed between the customer and the supplier.

Any wall thickness not conforming to the specified values due to the manufacturing process, because of deformation of the bearing backing in the area of marking or at non-load bearing places, shall be agreed between the customer and the supplier.

### 6.2 Line measurement around the circumference

Measurement of the wall thickness around the circumference shall be carried out at the measuring lines specified in [Figure 3](#) and [Tables 2](#) and [3](#).

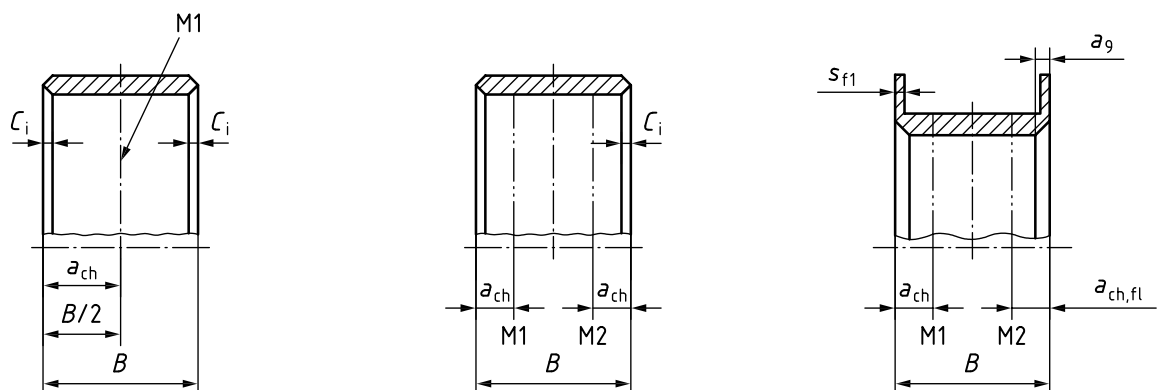

a) Thin wall bearing without flange,  $B < 15$  mm

b) Thin wall bearing without flange  $B \geq 15$  mm

c) Thin wall bearing with flanges

## ISO 3548-2:2020(E)

## Key

 $C_i$  inner chamfer width $a_{ch}$  distance to measuring position $a_{ch,fl}$  distance to measuring position for thin wall bearings with flanges

M1, M2 measuring line

Figure 3 — Position of measuring lines

Table 2 — Thin-walled half bearings without flange — Distance to measuring position,  $a_{ch}$ 

Width $B$	Distance to measuring position $a_{ch}$	Number of measuring lines M1, M2
$B \leq 15$	$B/2 - C_i$	1
$15 < B \leq 50$	4	2
$B > 50$	6	2

Table 3 — Thin-walled half bearings with flange — Distance to measuring position,  $a_{ch}$ 

Width $B$	Distance to measuring position $a_{ch}$	Number of measuring lines M1, M2
$B < 15$	$B/2$	1
$15 \leq B \leq 50$	$C_i + s_{fl} + a_g + 4 \text{ mm}$	2 <sup>a</sup>
$50 < B \leq 90$	$C_i + s_{fl} + a_g + 4 \text{ mm}$	2 <sup>a</sup>
$B > 90$	$C_i + s_{fl} + a_g + 8 \text{ mm}$	2 <sup>b</sup>

<sup>a</sup> Only valid for:  $C_i + s_{fl} + a_g + 4 \text{ mm} \leq B/2 - 2 \text{ mm}$ , otherwise only one measuring line shall be used.  
<sup>b</sup> Only valid for:  $C_i + s_{fl} + a_g + 8 \text{ mm} \leq B/2 - 2 \text{ mm}$ , otherwise only one measuring line shall be used.

## 6.3 Line measurement in axial direction

Measurement of the wall thickness in axial direction shall be carried out by using the definition of measuring lines specified in Figure 4 a) (Method A) or by using the definition of measuring lines specified in Figure 4 b) and Table 3 (Method B).

For Method B, the distance to the measuring position  $H$  shall not result into measurement within the crush relief area.

The position of the measuring lines for bearings with a nominal outside diameter greater than 150 mm is subject to agreement between the manufacturer and the customer.