

FINAL
DRAFT

INTERNATIONAL
STANDARD

ISO/FDIS
7915

ISO/TC 23/SC 17

Secretariat: SIS

Voting begins on:
2020-12-08

Voting terminates on:
2021-02-02

Forestry machinery — Portable chain-saws — Determination of handle strength

Matériel forestier — Scies à chaîne portatives — Détermination de la solidité des poignées

iTeh STANDARD PREVIEW
(standards.iteh.ai)

[ISO/FDIS 7915](https://standards.iteh.ai/catalog/standards/sist/7958d0b8-4fa4-4c21-a97e-8ba0d92ff986/iso-fdis-7915)

<https://standards.iteh.ai/catalog/standards/sist/7958d0b8-4fa4-4c21-a97e-8ba0d92ff986/iso-fdis-7915>

RECIPIENTS OF THIS DRAFT ARE INVITED TO SUBMIT, WITH THEIR COMMENTS, NOTIFICATION OF ANY RELEVANT PATENT RIGHTS OF WHICH THEY ARE AWARE AND TO PROVIDE SUPPORTING DOCUMENTATION.

IN ADDITION TO THEIR EVALUATION AS BEING ACCEPTABLE FOR INDUSTRIAL, TECHNOLOGICAL, COMMERCIAL AND USER PURPOSES, DRAFT INTERNATIONAL STANDARDS MAY ON OCCASION HAVE TO BE CONSIDERED IN THE LIGHT OF THEIR POTENTIAL TO BECOME STANDARDS TO WHICH REFERENCE MAY BE MADE IN NATIONAL REGULATIONS.



Reference number
ISO/FDIS 7915:2020(E)

© ISO 2020

iTeh STANDARD PREVIEW
(standards.iteh.ai)

ISO/FDIS 7915

<https://standards.iteh.ai/catalog/standards/sist/7958d0b8-4fa4-4c21-a97e-8ba0d92ff986/iso-fdis-7915>



COPYRIGHT PROTECTED DOCUMENT

© ISO 2020

All rights reserved. Unless otherwise specified, or required in the context of its implementation, no part of this publication may be reproduced or utilized otherwise in any form or by any means, electronic or mechanical, including photocopying, or posting on the internet or an intranet, without prior written permission. Permission can be requested from either ISO at the address below or ISO's member body in the country of the requester.

ISO copyright office
CP 401 • Ch. de Blandonnet 8
CH-1214 Vernier, Geneva
Phone: +41 22 749 01 11
Email: copyright@iso.org
Website: www.iso.org

Published in Switzerland

Contents

	Page
Foreword	iv
1 Scope	1
2 Normative references	1
3 Terms and definitions	1
4 Test procedure	1
4.1 Test temperature	1
4.2 Test performance	1
4.3 Load application	1
4.3.1 General	1
4.3.2 Fixation	3
4.3.3 Load application	3
4.3.4 Relative load directions	4
5 Test requirements	4
Bibliography	5

iTeh STANDARD PREVIEW (standards.iteh.ai)

ISO/FDIS 7915

<https://standards.iteh.ai/catalog/standards/sist/7958d0b8-4fa4-4c21-a97e-8ba0d92ff986/iso-fdis-7915>

Foreword

ISO (the International Organization for Standardization) is a worldwide federation of national standards bodies (ISO member bodies). The work of preparing International Standards is normally carried out through ISO technical committees. Each member body interested in a subject for which a technical committee has been established has the right to be represented on that committee. International organizations, governmental and non-governmental, in liaison with ISO, also take part in the work. ISO collaborates closely with the International Electrotechnical Commission (IEC) on all matters of electrotechnical standardization.

The procedures used to develop this document and those intended for its further maintenance are described in the ISO/IEC Directives, Part 1. In particular, the different approval criteria needed for the different types of ISO documents should be noted. This document was drafted in accordance with the editorial rules of the ISO/IEC Directives, Part 2 (see www.iso.org/directives).

Attention is drawn to the possibility that some of the elements of this document may be the subject of patent rights. ISO shall not be held responsible for identifying any or all such patent rights. Details of any patent rights identified during the development of the document will be in the Introduction and/or on the ISO list of patent declarations received (see www.iso.org/patents).

Any trade name used in this document is information given for the convenience of users and does not constitute an endorsement.

For an explanation of the voluntary nature of standards, the meaning of ISO specific terms and expressions related to conformity assessment, as well as information about ISO's adherence to the World Trade Organization (WTO) principles in the Technical Barriers to Trade (TBT), see www.iso.org/iso/foreword.html.

This document was prepared by Technical Committee [or Project Committee] ISO/TC 23, *Tractors and machinery for agriculture and forestry*, Subcommittee SC 17, *Manually portable forest machinery*.

This third edition cancels and replaces the second edition (ISO 7915:1991), which has been technically revised.

The main changes compared to the previous edition are as follows:

- the scope has been updated to be inclusive of chain-saws regardless of power source and inclusive of chain-saws for tree service;
- means of mounting the chain-saw, for a more secure and repeatable test, has been defined;
- directional application of test loads clarified;
- minimum test loads for chain-saws for tree service added to [Table 1](#);
- tolerances applied to all measurable;
- new figures have been included to show directions of load applications for chain-saws for forest service and chain-saws for tree service.

Any feedback or questions on this document should be directed to the user's national standards body. A complete listing of these bodies can be found at www.iso.org/members.html.

Forestry machinery — Portable chain-saws — Determination of handle strength

1 Scope

This document specifies a test method and strength requirements for the handles of portable hand-held chain-saws for use primarily in forestry and tree-service.

2 Normative references

The following documents are referred to in the text in such a way that some or all of their content constitutes requirements of this document. For dated references, only the edition cited applies. For undated references, the latest edition of the referenced document (including any amendments) applies.

ISO 6531, *Machinery for forestry — Portable chain-saws — Vocabulary*

ISO 6533, *Forestry machinery — Portable chain-saw front hand-guard — Dimensions and clearances*

ISO 7914, *Forestry machinery — Portable chain-saws — Minimum handle clearance and sizes*

3 Terms and definitions

For the purposes of this document, the terms and definitions given in ISO 6531 apply.

ISO and IEC maintain terminological databases for use in standardization at the following addresses:

- ISO Online browsing platform: available at <https://www.iso.org/obp>
- IEC Electropedia: available at <http://www.electropedia.org/>

4 Test procedure

4.1 Test temperature

The test temperature shall be (20 ± 5) °C.

4.2 Test performance

The test shall be performed with the test loads specified in 4.3. The load shall be gradually applied until the test load is achieved in such a manner that there is no impact damage. When the load specified in 4.3 is obtained, hold the load for a duration of (4 ± 1) s. The test shall be completed within 1 min.

4.3 Load application

4.3.1 General

The chain-saw handles shall be subjected to static loads as specified in Table 1, separately applied at both handles grip, in each of the six directions illustrated in Figure 1 or Figure 2 and as described in 4.3.3.

Table 1 — Test loads

Figure	Designation/ Power source/ engine displacement if applicable	Test loads		
		Forwards (X_1) and Backwards (X_2) $\left(\begin{smallmatrix} +0 \\ -1 \end{smallmatrix}\right) \%$	Up (Y_1) and Down (Y_2) $\left(\begin{smallmatrix} +0 \\ -1 \end{smallmatrix}\right) \%$	Right (Z_1) and Left (Z_2) $\left(\begin{smallmatrix} +0 \\ -1 \end{smallmatrix}\right) \%$
1	Chain-saw for forest service Combustion engine $\leq 50 \text{ cm}^3$ / Electric motor	700 N	700 N	350 N
1	Chain-saw for forest service combustion engine $> 50 \text{ cm}^3$	1 350 N	1 350 N	700 N
2	Chain-saw for Tree Service Combustion/Electric motor Definition per ISO 11681-2	500 N	500 N	250 N

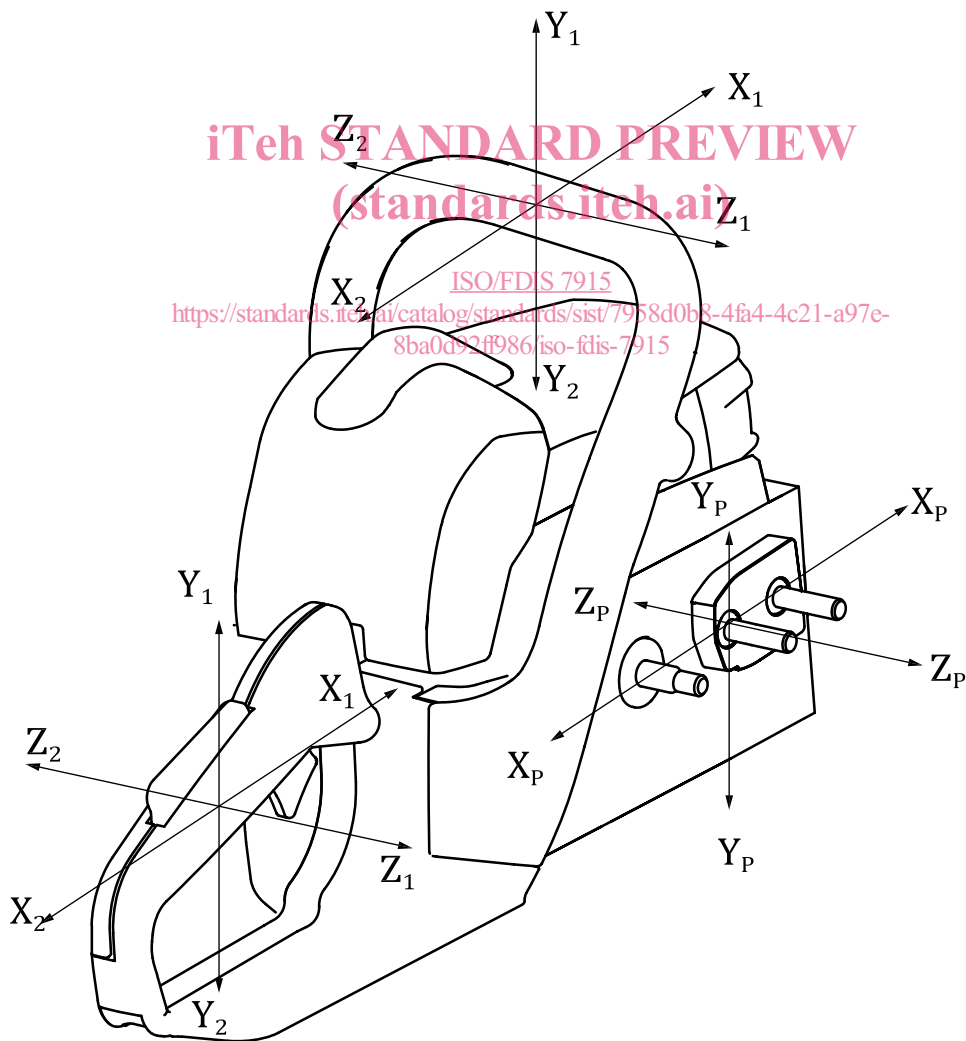

Figure 1 — Directions of load applications for chain-saws for forest service

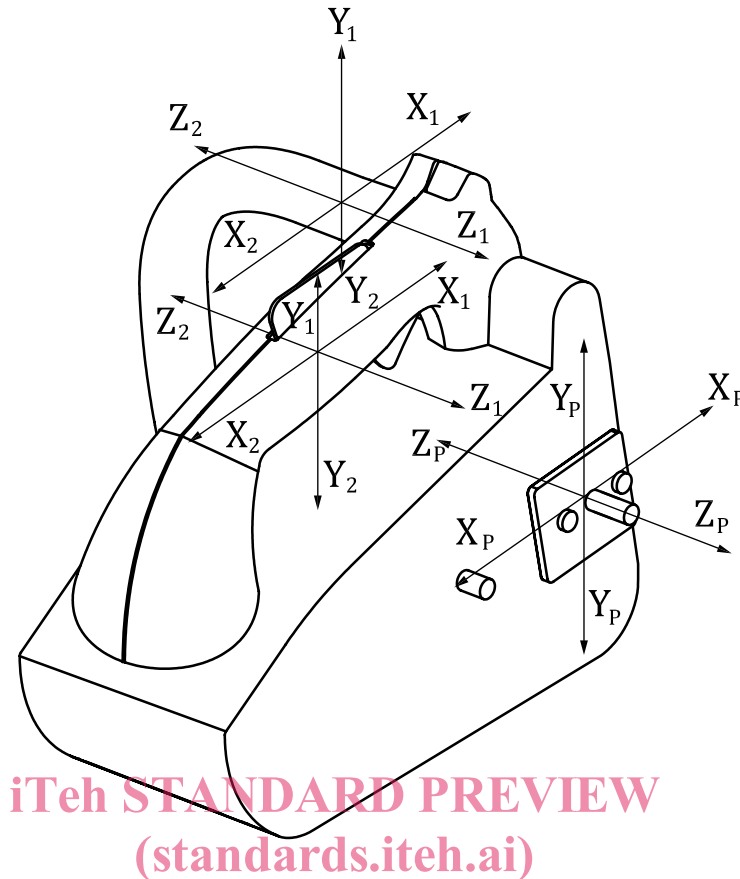

Figure 2 — Directions of load applications for chain-saws for tree service

ISO/FDIS 7915

<https://standards.iteh.ai/catalog/standards/sist/7958d0b8-4fa4-4c21-a97e-8ba0d92ff986/iso-fdis-7915>

4.3.2 Fixation

In each case, the chain-saw shall be fixed rigidly by the guide bar mounting pad and securely clamped to prevent flexing of the fixture greater than 2° when load is applied. The sprocket cover may be installed if needed. Direction X_p shall be aligned parallel to the theoretical centreline of the guide bar. A minimum clearance shall be maintained to prevent contact between the fixture and any part of the body of the chain-saw, excluding the bar mounting pad, so that they do not touch each other during the test.

4.3.3 Load application

4.3.3.1 General

The load shall be applied to each handle over an area of (70 ± 5) mm in width. A means to apply the loads to the handles shall be designed in such a way as to maintain directional orientation to X_p , Y_p and Z_p through the handle midpoint.

4.3.3.2 Load application to the front handle

The load shall be centred on the normal handle grip area at (50 ± 5) mm to the left of X_0 (see ISO 6533).

4.3.3.3 Load application to the rear handle

The load shall be centred on the grip area (25 ± 5) mm behind the point where the rear most end of the released throttle trigger enters the rear handle in the X direction, and centred on the handle profile in the Y and Z directions.

4.3.4 Relative load directions

The load shall be applied to each handle over an area of (70 ± 5) mm in width. A means to apply the loads to the handles shall be designed in such a way as to maintain directional orientation to X_p , Y_p and Z_p through the handle midpoint within $\pm 5^\circ$ relative to the guide bar mounting pad, while the load is applied. These directions shall be observed, irrespective of any deformation of the handles or the chain-saw body.

5 Test requirements

The chain-saw handles shall not break or crack when tested in accordance with [Clause 4](#). After the test it shall be possible that the operator can hold the machine and stop the engine even in the case of full failure of the vibration isolation system. Before and after the test, the dimensional requirements of ISO 6533 and ISO 7914 shall be complied with.

iTeh STANDARD PREVIEW
(standards.iteh.ai)

[ISO/FDIS 7915](#)

<https://standards.iteh.ai/catalog/standards/sist/7958d0b8-4fa4-4c21-a97e-8ba0d92ff986/iso-fdis-7915>

Bibliography

- [1] ISO 11681-2, *Machinery for forestry — Portable chain-saw safety requirements and testing — Part 2: Chain-saws for tree service*

iTeh STANDARD PREVIEW
(standards.iteh.ai)

[ISO/FDIS 7915](https://standards.iteh.ai/catalog/standards/sist/7958d0b8-4fa4-4c21-a97e-8ba0d92ff986/iso-fdis-7915)

<https://standards.iteh.ai/catalog/standards/sist/7958d0b8-4fa4-4c21-a97e-8ba0d92ff986/iso-fdis-7915>