

---

---

**Agricultural and forestry  
machinery — Safety requirements  
and testing for portable, hand-held,  
powered brush-cutters and grass-  
trimmers —**

**Part 1:  
Machines fitted with an integral  
combustion engine**

*Matériel agricole et forestier — Exigences de sécurité et essais pour  
débroussailleuses et coupe-herbe portatifs à moteur —  
Partie 1: Machines équipées d'un moteur à combustion interne  
intégré*



iTeh STANDARD PREVIEW  
(standards.iteh.ai)

ISO 11806-1:2022

<https://standards.iteh.ai/catalog/standards/sist/0fb6221e-0a43-4a5c-adea-e25336a166e0/iso-11806-1-2022>



**COPYRIGHT PROTECTED DOCUMENT**

© ISO 2022

All rights reserved. Unless otherwise specified, or required in the context of its implementation, no part of this publication may be reproduced or utilized otherwise in any form or by any means, electronic or mechanical, including photocopying, or posting on the internet or an intranet, without prior written permission. Permission can be requested from either ISO at the address below or ISO's member body in the country of the requester.

ISO copyright office  
CP 401 • Ch. de Blandonnet 8  
CH-1214 Vernier, Geneva  
Phone: +41 22 749 01 11  
Email: [copyright@iso.org](mailto:copyright@iso.org)  
Website: [www.iso.org](http://www.iso.org)

Published in Switzerland

# Contents

	Page
Foreword.....	v
Introduction.....	vi
<b>1 Scope.....</b>	<b>1</b>
<b>2 Normative references.....</b>	<b>1</b>
<b>3 Terms and definitions.....</b>	<b>2</b>
<b>4 Safety requirements and/or protective measures.....</b>	<b>4</b>
4.1 General.....	4
4.2 Handles.....	5
4.2.1 Requirements.....	5
4.2.2 Verification.....	6
4.3 Barrier and distance to cutting attachment for brush-cutters.....	6
4.3.1 Requirements.....	6
4.3.2 Verification.....	7
4.4 Harness.....	8
4.4.1 Requirements.....	8
4.4.2 Verification.....	8
4.5 Balance.....	8
4.5.1 Requirements.....	8
4.5.2 Verification.....	9
4.6 Cutting attachment strength.....	9
4.6.1 Requirements.....	9
4.6.2 Verification.....	9
4.7 Cutting attachment retention.....	9
4.7.1 Requirements.....	9
4.7.2 Verification.....	9
4.8 Cutting attachment guards.....	10
4.8.1 Requirements.....	10
4.8.2 Verification.....	10
4.9 Transport cover.....	10
4.9.1 Requirements.....	10
4.9.2 Verification.....	10
4.10 Length of flexible cutting lines.....	10
4.10.1 Requirements.....	10
4.10.2 Verification.....	11
4.11 Engine starting device.....	11
4.11.1 Requirements.....	11
4.11.2 Verification.....	11
4.12 Engine stopping device.....	11
4.12.1 Requirements.....	11
4.12.2 Verification.....	11
4.13 Throttle control.....	11
4.13.1 Position.....	11
4.13.2 Operation.....	11
4.13.3 Throttle control latch.....	13
4.14 Clutch.....	14
4.14.1 Requirements.....	14
4.14.2 Verification.....	14
4.15 Tanks.....	14
4.15.1 General.....	14
4.15.2 Fuel tank structural integrity.....	15
4.15.3 Fuel feed line strength and accessibility.....	15
4.16 Protection against contact with parts of the machine under high voltage.....	15
4.16.1 Requirements.....	15

4.16.2	Verification	15
4.17	Protection against contact with hot parts	15
4.17.1	Requirements	15
4.17.2	Verification	15
4.18	Exhaust gases	16
4.18.1	Requirement	16
4.18.2	Verification	16
4.19	Vibration	17
4.19.1	Reduction by design at source and by protective measures	17
4.19.2	Vibration measurement	17
4.20	Noise	17
4.20.1	Reduction by design at source and by protective measures	17
4.20.2	Noise measurement	17
4.21	Electromagnetic immunity	17
4.21.1	Requirements	17
4.21.2	Verification	17
<b>5</b>	<b>Information for use</b>	<b>18</b>
5.1	Instructions	18
5.1.1	General	18
5.1.2	Technical data	18
5.1.3	Other information	18
5.2	Marking	20
5.3	Warnings	21
5.4	Test of labels	22
5.4.1	Preparation of test specimens and control specimens	22
5.4.2	Wipe resistance test	22
5.4.3	Adhesion test	23
<b>Annex A</b>	<b>(normative) Cutting attachment impact and spin test</b>	<b>24</b>
<b>Annex B</b>	<b>(normative) Thrown objects test</b>	<b>26</b>
<b>Annex C</b>	<b>(informative) List of significant hazards</b>	<b>30</b>
<b>Annex D</b>	<b>(normative) Structural integrity of fuel tanks</b>	<b>32</b>
<b>Annex E</b>	<b>(normative) Procedures for the evaluation of the strength and accessibility of fuel feed lines</b>	<b>33</b>
<b>Bibliography</b>		<b>34</b>

## Foreword

ISO (the International Organization for Standardization) is a worldwide federation of national standards bodies (ISO member bodies). The work of preparing International Standards is normally carried out through ISO technical committees. Each member body interested in a subject for which a technical committee has been established has the right to be represented on that committee. International organizations, governmental and non-governmental, in liaison with ISO, also take part in the work. ISO collaborates closely with the International Electrotechnical Commission (IEC) on all matters of electrotechnical standardization.

The procedures used to develop this document and those intended for its further maintenance are described in the ISO/IEC Directives, Part 1. In particular, the different approval criteria needed for the different types of ISO documents should be noted. This document was drafted in accordance with the editorial rules of the ISO/IEC Directives, Part 2 (see [www.iso.org/directives](http://www.iso.org/directives)).

Attention is drawn to the possibility that some of the elements of this document may be the subject of patent rights. ISO shall not be held responsible for identifying any or all such patent rights. Details of any patent rights identified during the development of the document will be in the Introduction and/or on the ISO list of patent declarations received (see [www.iso.org/patents](http://www.iso.org/patents)).

Any trade name used in this document is information given for the convenience of users and does not constitute an endorsement.

For an explanation of the voluntary nature of standards, the meaning of ISO specific terms and expressions related to conformity assessment, as well as information about ISO's adherence to the World Trade Organization (WTO) principles in the Technical Barriers to Trade (TBT), see [www.iso.org/iso/foreword.html](http://www.iso.org/iso/foreword.html).

This document was prepared by Technical Committee ISO/TC 23, *Tractors and machinery for agriculture and forestry*, Subcommittee SC 17, *Manually portable (hand-held) powered lawn and garden equipment and forest machinery*, in collaboration with the European Committee for Standardization (CEN) Technical Committee CEN/TC 144, *Tractors and machinery for agriculture and forestry*, in accordance with the Agreement on technical cooperation between ISO and CEN (Vienna Agreement).

This second edition cancels and replaces the first edition (ISO 11806-1:2011), which has been technically revised.

The main changes compared to the previous edition are as follows:

- [Figure 3](#) has been revised to provide examples of handle distance;
- a force requirement in the throttle trigger lock-out performance test has been added;
- [Figures 5a](#) and [5b](#) have been added to clarify throttle trigger lock-out performance test;
- fuel tank structural integrity test requirements have been added by including a new [Annex D](#);
- fuel line strength and accessibility requirements have been added by including a new [Annex E](#);
- [Annex A](#), cutting attachment impact and spin test, has been revised for repeatability.

A list of all parts in the ISO 11806 series can be found on the ISO website.

Any feedback or questions on this document should be directed to the user's national standards body. A complete listing of these bodies can be found at [www.iso.org/members.html](http://www.iso.org/members.html).

## Introduction

This document is a type-C standard as stated in ISO 12100:2010.

This document is of relevance, in particular, for the following stakeholder groups representing the market players with regard to machinery safety:

- machine manufacturers (small, medium and large enterprises);
- health and safety bodies (regulators, accident prevention organisations, market surveillance, etc.).

Others can be affected by the level of machinery safety achieved with the means of the document by the above-mentioned stakeholder groups:

- machine users/employers (small, medium and large enterprises);
- machine users/employees (e.g. trade unions, organizations for people with special needs);
- service providers, e.g. for maintenance (small, medium and large enterprises);
- consumers (in case of machinery intended for use by consumers).

The above-mentioned stakeholder groups have been given the possibility to participate at the drafting process of this document.

The machinery concerned and the extent to which hazards, hazardous situations or hazardous events are covered are indicated in the scope of this document.

When requirements of this type-C standard are different from those which are stated in type-A or type-B standards, the requirements of this type-C standard take precedence over the requirements of the other standards for machines that have been designed and built according to the requirements of this type-C standard.

<https://standards.iteh.ai/catalog/standards/sist/0fb6221e-0a43-4a5c-adea-e25336a166e0/iso-11806-1-2022>

# Agricultural and forestry machinery — Safety requirements and testing for portable, hand-held, powered brush-cutters and grass-trimmers —

## Part 1: Machines fitted with an integral combustion engine

### 1 Scope

This document gives safety requirements and measures for their verification for the design and construction of portable hand-held, powered brush-cutters and grass-trimmers (hereafter called machines) having an integral combustion engine as their power unit and mechanical power transmission between the power source and the cutting attachment. Methods for the elimination or reduction of hazards arising from the use of these machines and the type of information on safe working practices to be provided by the manufacturer are specified.

This document deals with all significant hazards, hazardous situations and hazardous events relevant to these machines, as well as when they are used as intended and under conditions of misuse which are reasonably foreseeable by the manufacturer.

This document is not applicable to machines equipped with metallic cutting attachments consisting of more than one piece, such as pivoting chains or flail blades.

NOTE See [Annex C](#) for a list of significant hazards.

This document is applicable to portable, hand-held, powered brush-cutters and grass-trimmers manufactured after its date of publication.

### 2 Normative references

The following documents are referred to in the text in such a way that some or all of their content constitutes requirements of this document. For dated references, only the edition cited applies. For undated references, the latest edition of the referenced document (including any amendments) applies.

ISO 683-4:2016, *Heat-treatable steels, alloy steels and free-cutting steels — Part 4: Free-cutting steels*

ISO 3767-1:2016, *Tractors, machinery for agriculture and forestry, powered lawn and garden equipment — Symbols for operator controls and other displays — Part 1: Common symbols*

ISO 3767-5:2016, *Tractors, machinery for agriculture and forestry, powered lawn and garden equipment — Symbols for operator controls and other displays — Part 5: Symbols for manual portable forestry machines*

ISO 7112:2018, *Machinery for forestry — Portable brush-cutters and grass-trimmers — Vocabulary*

ISO 7113:1999, *Portable hand-held forestry machines — Cutting attachments for brush cutters — Single-piece metal blades*

ISO 7918:1995, *Forestry machinery — Portable brush-cutters and grass-trimmers — Cutting attachment guard dimensions*

ISO 8380:1993, *Forestry machinery — Portable brush-cutters and grass-trimmers — Cutting attachment guard strength*

ISO 12100:2010, *Safety of machinery — General principles for design — Risk assessment and risk reduction*

## ISO 11806-1:2022(E)

ISO 13857:2019, *Safety of machinery — Safety distances to prevent hazard zones being reached by upper and lower limbs*

ISO 14982:1998, *Agricultural and forestry machinery — Electromagnetic compatibility — Test methods and acceptance criteria*

ISO 22867:2021, *Forestry and gardening machinery — Vibration test code for portable hand-held machines with internal combustion engine — Vibration at the handles*

ISO 22868:2021, *Forestry and gardening machinery — Noise test code for portable hand-held machines with internal combustion engine — Engineering method (Grade 2 accuracy)*

IEC 61032:1997, *Protection of persons and equipment by enclosures — Probes for verification*

### 3 Terms and definitions

For the purposes of this document, the terms and definitions given in ISO 7112:2018, ISO 12100:2010 and the following apply.

ISO and IEC maintain terminological databases for use in standardization at the following addresses:

- IEC Electropedia: available at <http://www.electropedia.org/>
- ISO Online browsing platform: available at <https://www.iso.org/obp>

#### 3.1 machine

complete brush-cutter, brush saw or grass-trimmer, including power unit, drive shaft tube, cutting attachment and guard, but excluding the harness

ISO 11806-1:2022

<https://standards.iteh.ai/catalog/standards/sist/0fb6221e-0a43-4a5c-adea-e25336a166e0/iso-11806-1-2022>



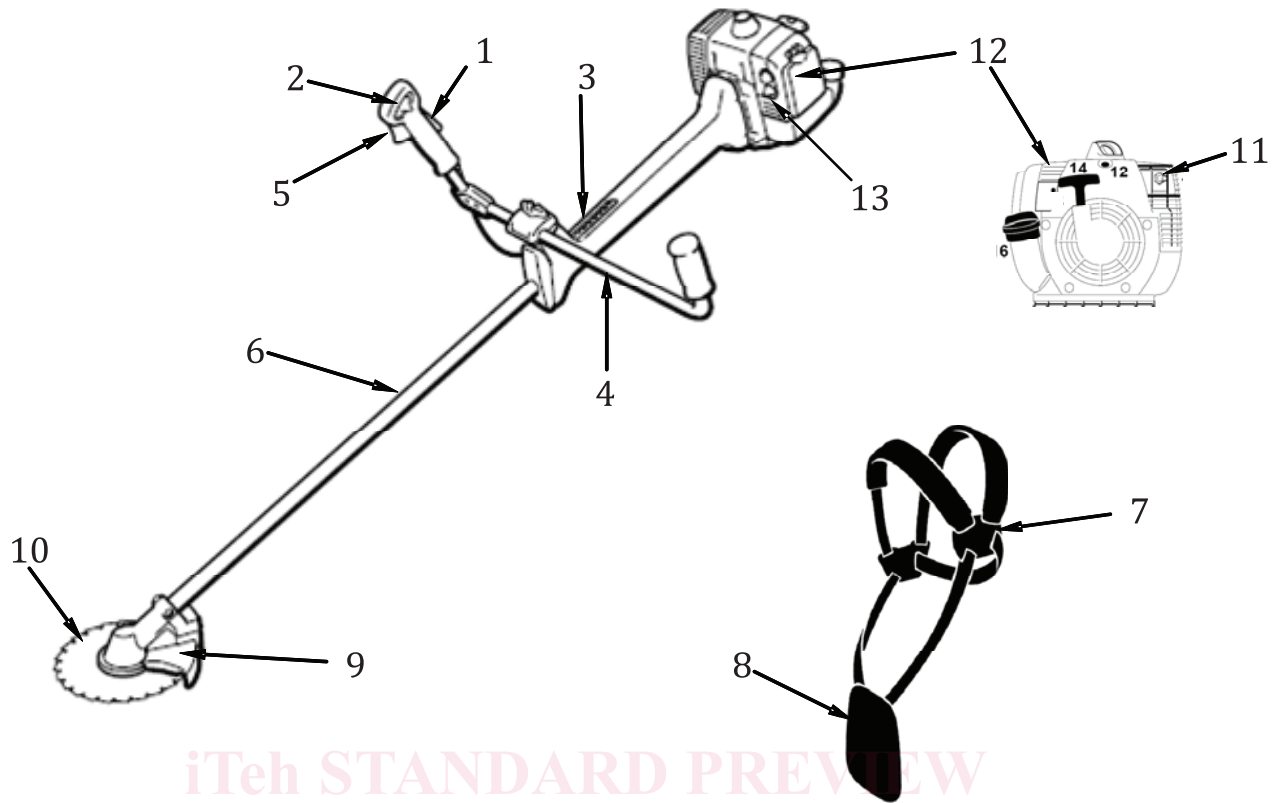

**Key**

- 1 throttle trigger lock-out
- 2 stop switch
- 3 suspension point
- 4 handle
- 5 throttle trigger
- 6 drive shaft tube
- 7 harness, quick-release mechanism
- 8 harness, hip pad
- 9 cutting attachment guard
- 10 cutting attachment, e.g. saw blade
- 11 muffler
- 12 power unit
- 13 choke

**Figure 1 — Machine (brush-cutter) with integral combustion engine**

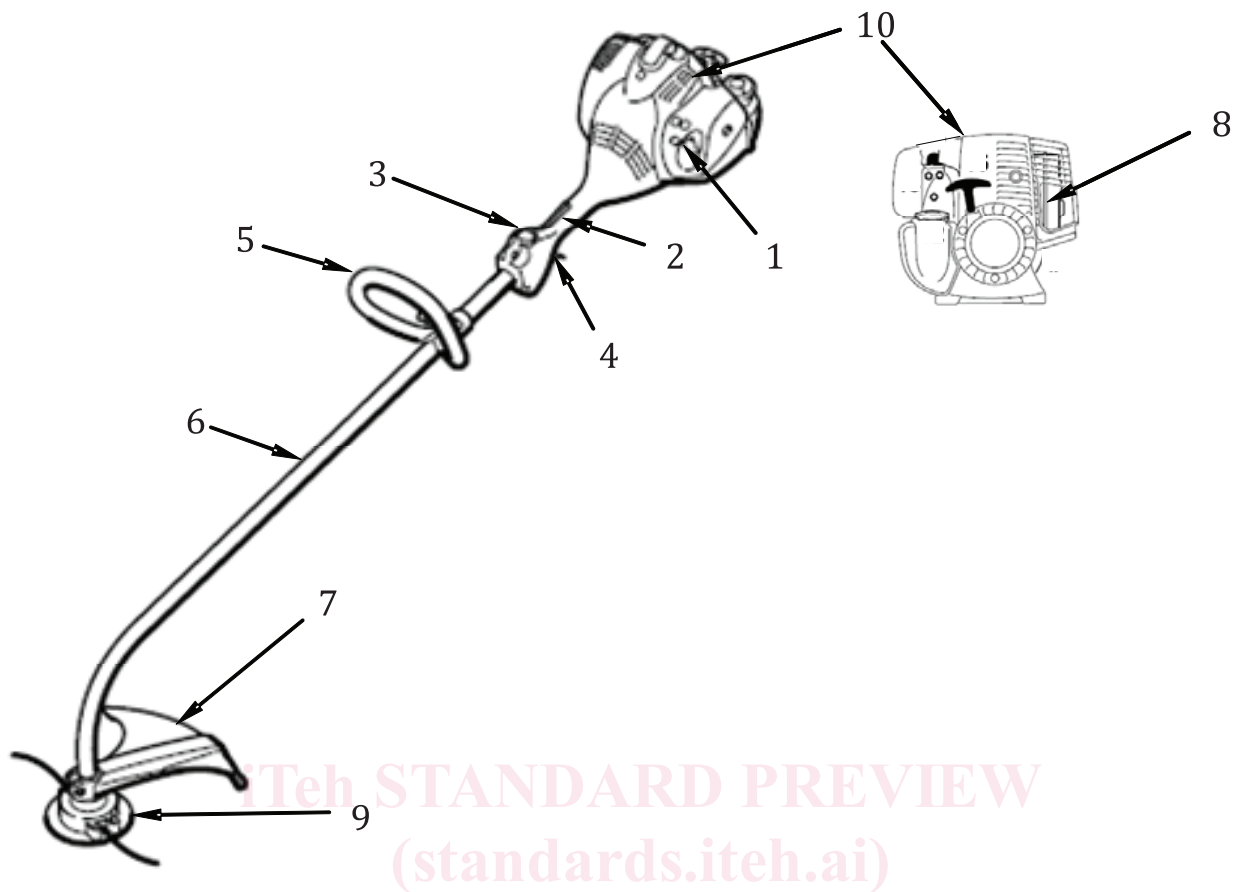

**Key**

- 1 choke
- 2 rear handle
- 3 stop switch
- 4 throttle trigger
- 5 front handle
- 6 drive shaft tube
- 7 cutting attachment guard
- 8 muffler
- 9 cutting attachment, e.g. string trimmer head
- 10 power unit

ISO 11806-1:2022

11806-1-2022

**Figure 2 — Machine (grass-trimmer) with integral combustion engine**

## 4 Safety requirements and/or protective measures

### 4.1 General

Machines shall comply with the safety requirements and/or protective measures of this clause. In addition, the machine shall be designed according to the principles of ISO 12100:2010 for relevant but not significant hazards which are not dealt with by this document. The machine shall also be marked according to 5.2 and carry warnings according to 5.3.

The safe operation of a brush-cutter and a grass-trimmer depends on both the safety requirements given in this clause and the safe working conditions associated with the use of adequate personal

protection equipment (PPE), such as gloves, slip-resistant footwear, and leg, eye and hearing protection equipment, as well as safe working procedures (see 5.1).

The instructions to be provided with the machine shall conform with 5.1.

If a grass-trimmer can be converted to a brush-cutter, then the converted machine shall conform with the requirements for a brush-cutter and vice versa.

The overall safety of the separate cutting attachment shall be verified as a part of the complete machine.

Except where otherwise specified in this document, the safety distances specified in ISO 13857:2019, 4.2.4.1 and 4.2.4.3 shall be met.

If a special tool is required to replace a cutting attachment, it shall be supplied with the machine.

## 4.2 Handles

### 4.2.1 Requirements

The machine shall have a handle for each hand. These handles shall be designed such that:

- they can be fully gripped by an operator when wearing gloves;
- they provide the necessary sureness of grip by their shaping and surface;
- they have a length of at least 100 mm;
- the distance  $l$  (see Figure 3) between the centre of the handles is at least 500 mm for those machines which can be equipped with metal saw blades, and at least 250 mm for all others;
- they are adjustable so that a suitable ergonomic working position can be achieved. An adjustment below the minimum distance  $l$  shall be prevented by design.

NOTE The position of the operator relative to the cutting attachment is defined by the suspension point (see 4.5 and 4.6) and the barrier (see 4.3).

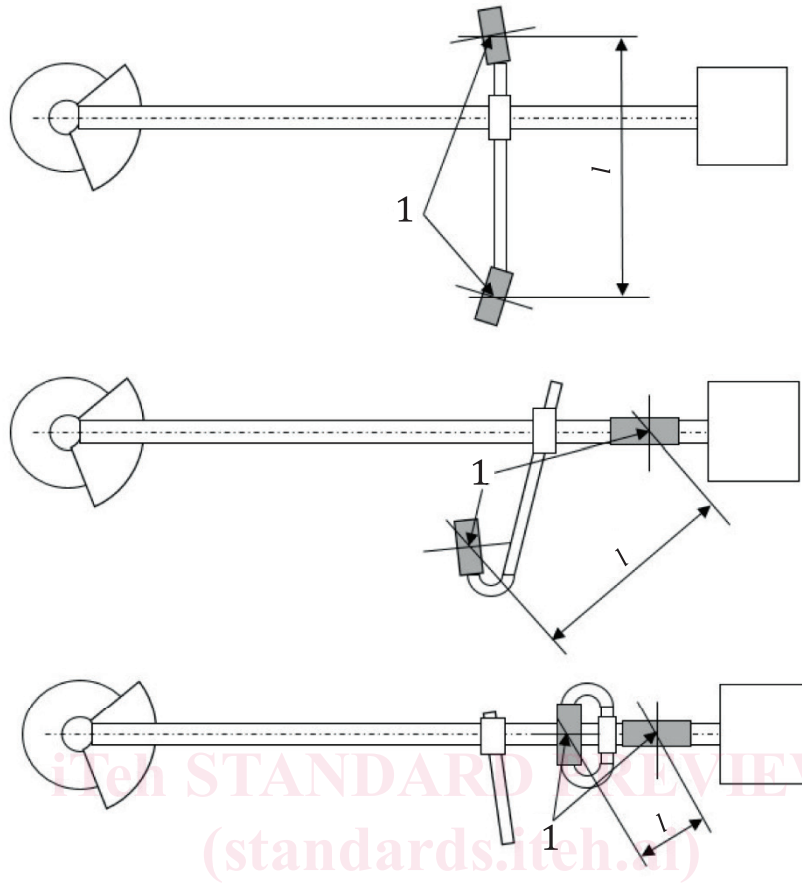

**Key**

- 1 centre of gripping area

**Figure 3 — Examples for handle distance *l***

**4.2.2 Verification**

The design, adjustment and dimensions shall be verified by inspection and measurements and function test.

**4.3 Barrier and distance to cutting attachment for brush-cutters**

**4.3.1 Requirements**

Brush-cutters shall be equipped with a barrier to prevent an unintentional contact with the cutting attachment during operation.

The barrier shall project at least 200 mm horizontally and perpendicularly from the centre-line of the drive shaft tube. This function can also be performed by the handle assembly. See [Figure 4](#).

The minimum straight line distance from the rear of the barrier (2) at a width of 200 mm (2) to the nearest unguarded point of the cutting attachment (1) shall be at least 830 mm, where the unguarded point of the cutting attachment is the intersection between the plane perpendicular to the cutting path and the side-edge of the cutting attachment guard. See [Figure 4](#).

Barriers that are to be removed as a part of maintenance procedures or assembled by the operator, described in the instructions, shall be fixed by systems that can be opened or removed only with tools. The fixing system for barriers which are independent from the handle assembly shall be permanently attached to the barrier and/or the machine when the barrier is removed.

Dimensions in millimetres

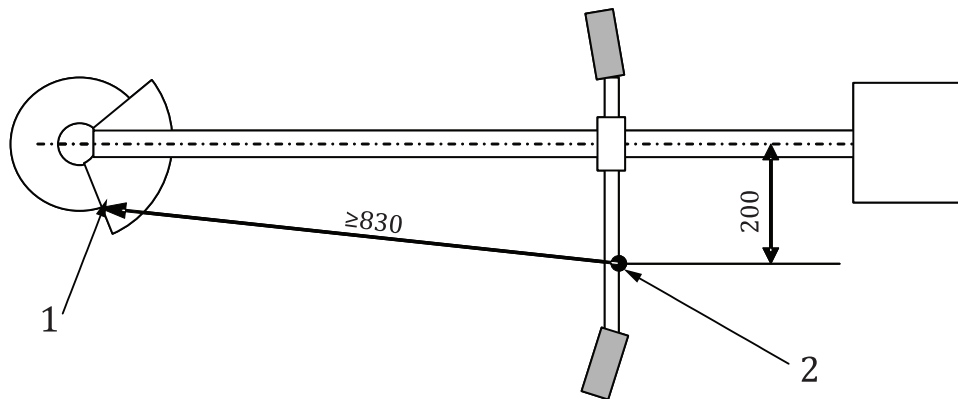

a) Bicycle-type handle serving as a barrier

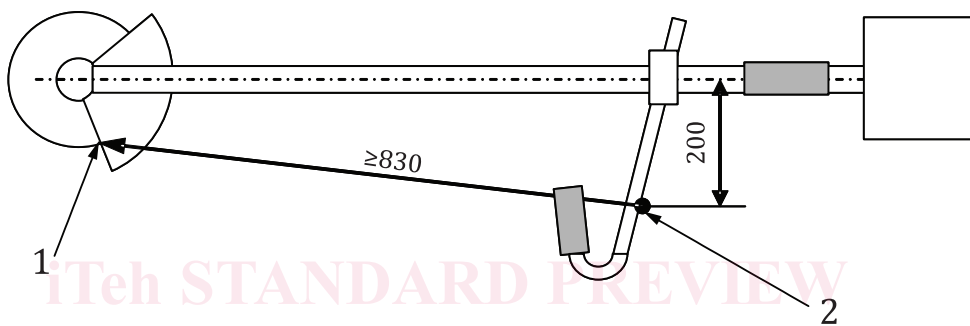

b) Front and rear handles with front handle serving as a barrier

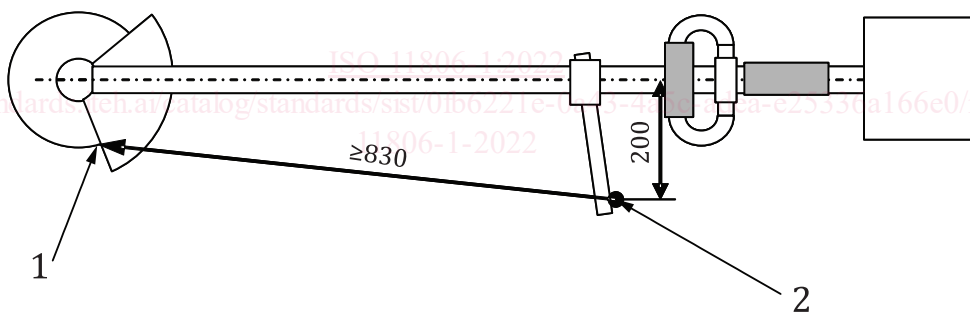

c) Front and rear handle with separate barrier

**Key**

- 1 unguarded point of the cutting attachment
- 2 rear of the handle bar/barrier

**Figure 4 — Example of machines with different handle configurations, barrier and distance to cutting attachment**

**4.3.2 Verification**

The design, adjustment and dimensions shall be verified by inspection and measurements.