

ISO/TC 23/SC 17

Secretariat: SIS

Voting begins on:  
2020-03-02

Voting terminates on:  
2020-04-27

---

---

## Forestry machinery — Portable chain-saw front hand-guard — Dimensions and clearances

*Machines forestières — Protecteur de la main tenant la poignée avant des scies à chaîne portatives — Dimensions et dégagements*

**iTeh STANDARD PREVIEW**  
(standards.iteh.ai)  
Full standard:  
<https://standards.iteh.ai/catalog/standards/sist/7a337190-4b70-40d4-ab2f-39377779dc88/iso-6533-2020>

RECIPIENTS OF THIS DRAFT ARE INVITED TO SUBMIT, WITH THEIR COMMENTS, NOTIFICATION OF ANY RELEVANT PATENT RIGHTS OF WHICH THEY ARE AWARE AND TO PROVIDE SUPPORTING DOCUMENTATION.

IN ADDITION TO THEIR EVALUATION AS BEING ACCEPTABLE FOR INDUSTRIAL, TECHNOLOGICAL, COMMERCIAL AND USER PURPOSES, DRAFT INTERNATIONAL STANDARDS MAY ON OCCASION HAVE TO BE CONSIDERED IN THE LIGHT OF THEIR POTENTIAL TO BECOME STANDARDS TO WHICH REFERENCE MAY BE MADE IN NATIONAL REGULATIONS.



Reference number  
ISO/FDIS 6533:2020(E)

**iTeh STANDARD PREVIEW**  
**(standards.iteh.ai)**  
Full standard:  
<https://standards.iteh.ai/catalog/standards/sist/7a3179c0-4b70-40d4-ab2f-39377779dc88/iso-6533-2020>



**COPYRIGHT PROTECTED DOCUMENT**

© ISO 2020

All rights reserved. Unless otherwise specified, or required in the context of its implementation, no part of this publication may be reproduced or utilized otherwise in any form or by any means, electronic or mechanical, including photocopying, or posting on the internet or an intranet, without prior written permission. Permission can be requested from either ISO at the address below or ISO's member body in the country of the requester.

ISO copyright office  
CP 401 • Ch. de Blandonnet 8  
CH-1214 Vernier, Geneva  
Phone: +41 22 749 01 11  
Fax: +41 22 749 09 47  
Email: [copyright@iso.org](mailto:copyright@iso.org)  
Website: [www.iso.org](http://www.iso.org)

Published in Switzerland

# Contents

	Page
Foreword .....	iv
<b>1 Scope .....</b>	<b>1</b>
<b>2 Normative references .....</b>	<b>1</b>
<b>3 Terms and definitions .....</b>	<b>2</b>
<b>4 General .....</b>	<b>2</b>
<b>5 Gauge dimensions .....</b>	<b>2</b>
<b>6 Determination of reference point <math>X_0</math> .....</b>	<b>2</b>
<b>7 Front hand-guard dimensions .....</b>	<b>4</b>
7.1 Front hand-guard width, $W_1$ .....	4
7.2 Front hand-guard height over front handle, $H_1$ and $H_{1A}$ .....	5
7.3 Line between $X_0$ and the rearmost part of the unprotected saw-chain .....	6
7.4 Front hand-guard openings, $H_3$ .....	7
<b>8 Clearance between the hand-guard and the chain-saw body, <math>H_2</math> .....</b>	<b>7</b>
<b>9 Clearances between the hand-guard and the front handle .....</b>	<b>7</b>

iTeh STANDARD PREVIEW  
 (standards.iteh.ai)  
 Full standard:  
<https://standards.iteh.ai/catalog/standards/sist/7a3179e0-4b70-40d4-ab2f-39377779dc88/iso-6533-2020>

## Foreword

ISO (the International Organization for Standardization) is a worldwide federation of national standards bodies (ISO member bodies). The work of preparing International Standards is normally carried out through ISO technical committees. Each member body interested in a subject for which a technical committee has been established has the right to be represented on that committee. International organizations, governmental and non-governmental, in liaison with ISO, also take part in the work. ISO collaborates closely with the International Electrotechnical Commission (IEC) on all matters of electrotechnical standardization.

The procedures used to develop this document and those intended for its further maintenance are described in the ISO/IEC Directives, Part 1. In particular, the different approval criteria needed for the different types of ISO documents should be noted. This document was drafted in accordance with the editorial rules of the ISO/IEC Directives, Part 2 (see [www.iso.org/directives](http://www.iso.org/directives)).

Attention is drawn to the possibility that some of the elements of this document may be the subject of patent rights. ISO shall not be held responsible for identifying any or all such patent rights. Details of any patent rights identified during the development of the document will be in the Introduction and/or on the ISO list of patent declarations received (see [www.iso.org/patents](http://www.iso.org/patents)).

Any trade name used in this document is information given for the convenience of users and does not constitute an endorsement.

For an explanation of the voluntary nature of standards, the meaning of ISO specific terms and expressions related to conformity assessment, as well as information about ISO's adherence to the World Trade Organization (WTO) principles in the Technical Barriers to Trade (TBT) see [www.iso.org/iso/foreword.html](http://www.iso.org/iso/foreword.html).

This document was prepared by Technical Committee ISO/TC 23, *Tractors and machinery for agriculture and forestry*, Subcommittee SC 17, *Manually portable forest machinery*.

This fifth edition cancels and replaces the fourth edition (ISO 6533:2012), which has been technically revised.

The main changes compared to the previous edition are as follows:

- to reflect worst case conditions, it has been clarified, that handle clearance between front handle and front hand-guard, measured with gauge A, shall be fulfilled without pre-load on the front hand-guard as described in [Clause 4 b\) 2\)](#);
- to reflect worst case conditions, it has been clarified that height  $H_1$  shall be passed with pre-load on the front hand-guard as described in [Clause 4 b\) 2\)](#) and  $H_{1A}$  without pre-load on the front hand-guard;
- to proscribe direct contact by the fingers ( $\leq 120$  mm), a safety radius  $> 120$  mm around the closest unprotected part of the saw-chain was defined.

Any feedback or questions on this document should be directed to the user's national standards body. A complete listing of these bodies can be found at [www.iso.org/members.html](http://www.iso.org/members.html).

# Forestry machinery — Portable chain-saw front hand-guard — Dimensions and clearances

## 1 Scope

This document specifies the dimensions and clearances for front hand-guards and their openings on portable hand-held chain-saws. These dimensions and clearances ensure the necessary safety provided by the hand-guard, which serves as both a shield between the operator's hand and the saw-chain and as an actuator for manually operated chain brakes.

For chain-saws with wrap around handles (see [Figure 1](#)), this document is not applicable to the portion of the front handle to the right (when viewed from the rear) of the top brace.

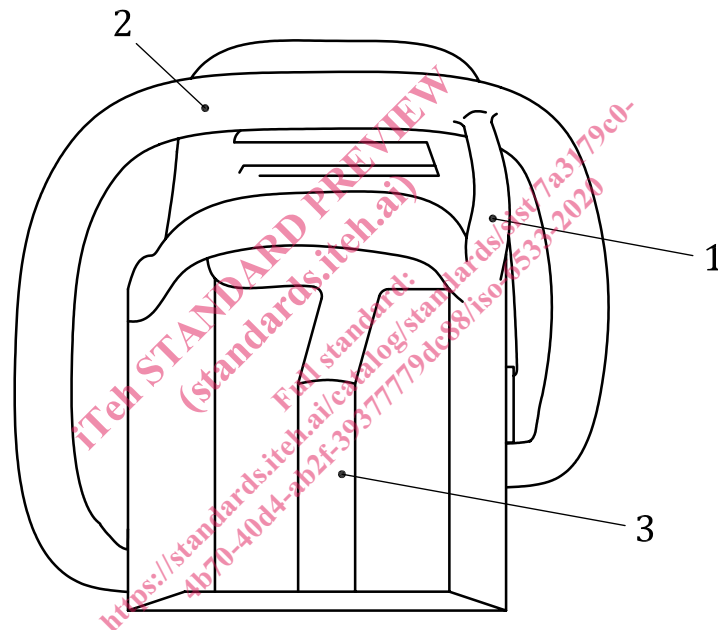

### Key

- 1 top brace
- 2 front handle
- 3 rear handle

**Figure 1 — Example of a chain-saw with a wrap around the handle — Rear view**

## 2 Normative references

The following documents are referred to in the text in such a way that some or all of their content constitutes requirements of this document. For dated references, only the edition cited applies. For undated references, the latest edition of the referenced document (including any amendments) applies.

ISO 6531, *Machinery for forestry — Portable chain-saws — Vocabulary*

IEC 61032, *Protection of persons and equipment by enclosures — Probes for verification*

### 3 Terms and definitions

For the purposes of this document, the terms and definitions given in ISO 6531 apply.

ISO and IEC maintain terminological databases for use in standardization at the following addresses:

- ISO Online browsing platform: available at <https://www.iso.org/obp>
- IEC Electropedia: available at <http://www.electropedia.org/>

### 4 General

The dimensions of the front hand-guard and the clearances shall be in relation to the intended position of the left hand on the front handle during vertical cutting (bucking), determined using defined gauges (see [Clause 5](#)).

Unless otherwise specified, the following is applicable when determining the dimensions and clearances.

- a) The chain-saw shall be kept in the upright position with guide bar centreline horizontal; and the total forces when applying the gauges (force on gauge plus gauge gravity force in probing direction) shall be  $10\text{ N}_{-1}^0\text{ N}$ .
- b) If the front hand-guard also activates the chain brake, the measurements shall be made
  - 1) with the front hand-guard in the position for non-activated chain brake, and
  - 2) with a force of  $10\text{ N}_{-1}^0\text{ N}$  applied at the top edge of the guard, at  $45^\circ$  in a forward and downward direction relative to the guide bar centreline and 50 mm to the left of the reference point  $X_0$  (see [Clause 6](#) and [Figure 5](#)), when viewed from the rear (to eliminate any free play in the hand-guard mounting).

### 5 Gauge dimensions

Rigid gauges of the types and sizes specified in [Table 1](#) shall be used to determine the dimensions and clearances.

**Table 1 — Gauge dimensions**

Dimensions in millimetres

Gauge type	Diameter $D \pm 0,1$	Length $L \pm 0,1$	Corner radius $r_{-0,2}^0$
A	35	100	5
B	70	100	0,5
C	56	82	0,5

### 6 Determination of reference point $X_0$

**6.1** The reference point  $X_0$  shall be determined, when viewed from the rear, using a type A gauge kept furthest to the right side of the front handle, directly below and in line with the centreline of the front

handle and held horizontally, so that the gauge contacts the housing and the front handle (see Figure 2).  $X_0$  is the contact point of the upper right edge of the gauge with the front handle.

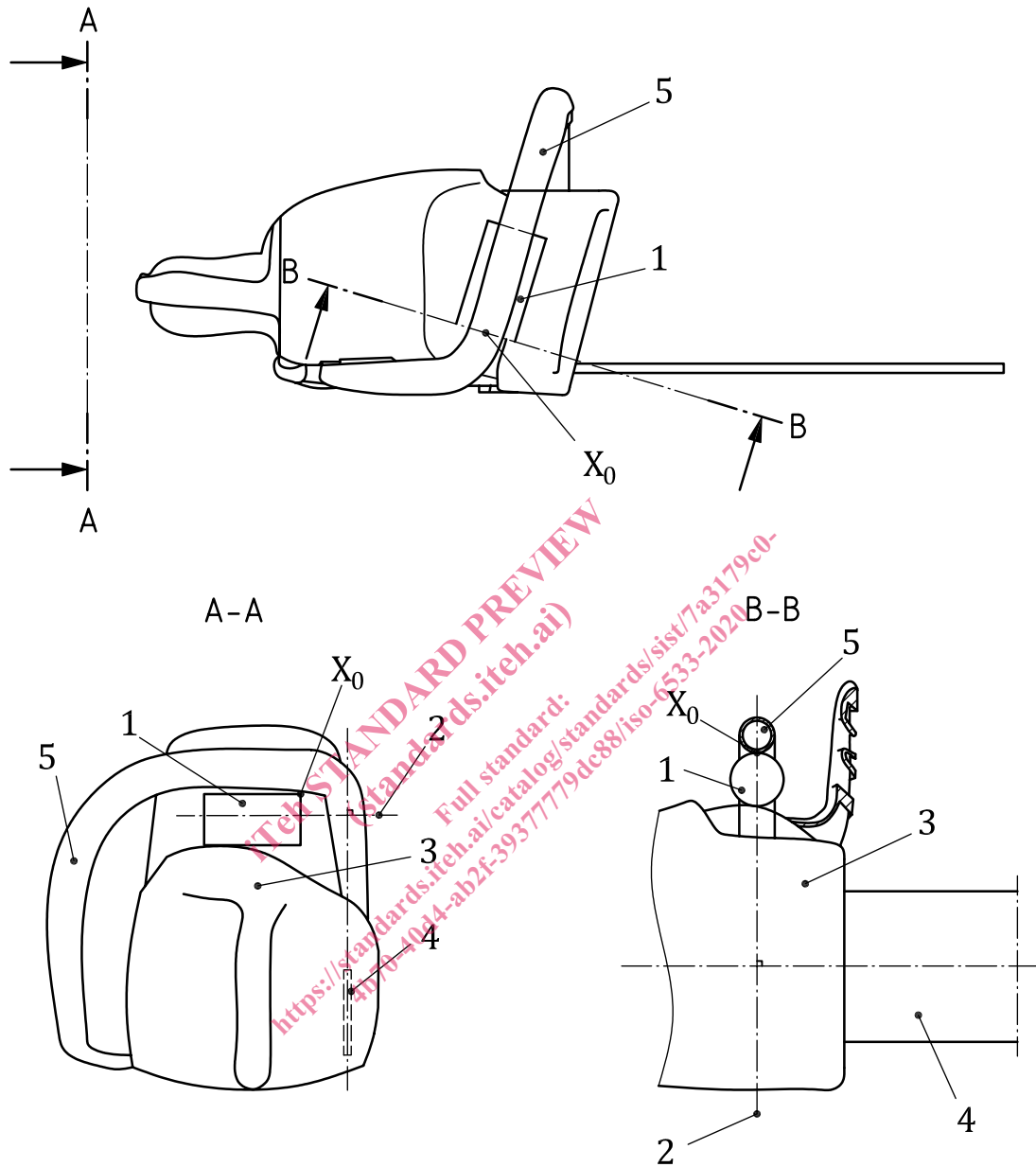

#### Key

- 1 type A gauge
- 2 type A gauge centreline
- 3 chain-saw body
- 4 guide bar
- 5 front handle

**Figure 2 — Definition of reference point  $X_0$  when there is gauge contact between the housing and the front handle**

**6.2** When the chain-saw is designed in such a way that a type A gauge of 100 mm length cannot be inserted between the handle and the housing, and  $X_0$  cannot be determined using such a gauge, the gauge length can be shortened (though no more than necessary). Using this modified gauge,  $X_0$  shall be determined according to all other requirements of 6.1.





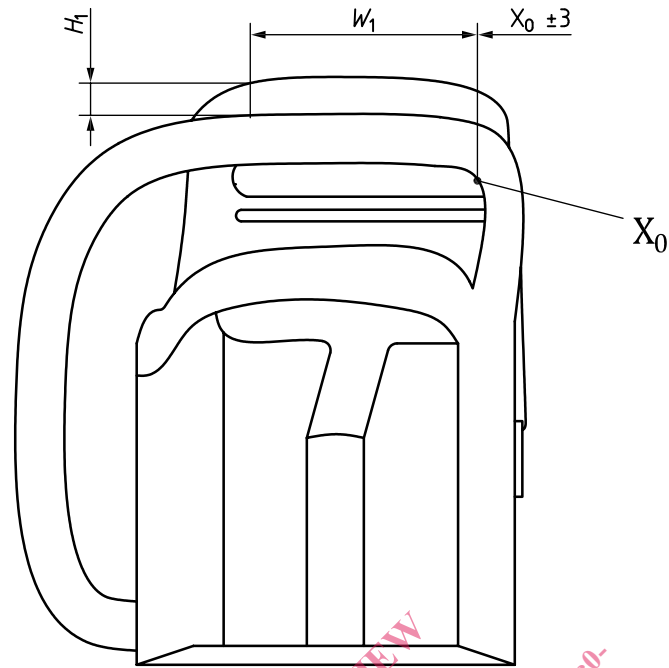

Figure 4 — Front hand-guard width,  $W_1$ , from the rear view of the chain-saw

## 7.2 Front hand-guard height over front handle, $H_1$ and $H_{1A}$

The measurement of the vertical height  $H_1$  and  $H_{1A}$  shall be made in a plane parallel to the guide bar plane and perpendicular to the guide bar centreline (see Figure 5).

Any free play in the guide bar fixing shall be taken up by tightening the guide bar to the saw body in its uppermost position.

The height,  $H_1$ , above the top contour of the front handle shall be at least 20 mm.

When the front hand-guard also activates the chain brake, this height shall be at least

- 20 mm with disengaged chain brake ( $H_1$ ), with a pre-load according to Clause 4 b) 2) applied to the guard, and
- 0 mm for engaged chain brake ( $H_{1A}$ ) without pre-load.