

ISO/TC 23/SC 17

Secretariat: SIS

Voting begins on:
2021-07-01

Voting terminates on:
2021-08-26

Forestry and gardening machinery — Vibration test code for portable hand-held machines with internal combustion engine — Vibration at the handles

Machines forestières et machines de jardin — Code d'essai des vibrations pour machines portatives tenues à la main à moteur à combustion interne — Vibrations au niveau des poignées

iTeh STANDARD PREVIEW
(standards.iteh.ai)

[ISO/FDIS 22867](https://standards.iteh.ai/catalog/standards/sist/89da88e7-8940-4832-89c0-a1bf0ca28926/iso-fdis-22867)

<https://standards.iteh.ai/catalog/standards/sist/89da88e7-8940-4832-89c0-a1bf0ca28926/iso-fdis-22867>

RECIPIENTS OF THIS DRAFT ARE INVITED TO SUBMIT, WITH THEIR COMMENTS, NOTIFICATION OF ANY RELEVANT PATENT RIGHTS OF WHICH THEY ARE AWARE AND TO PROVIDE SUPPORTING DOCUMENTATION.

IN ADDITION TO THEIR EVALUATION AS BEING ACCEPTABLE FOR INDUSTRIAL, TECHNOLOGICAL, COMMERCIAL AND USER PURPOSES, DRAFT INTERNATIONAL STANDARDS MAY ON OCCASION HAVE TO BE CONSIDERED IN THE LIGHT OF THEIR POTENTIAL TO BECOME STANDARDS TO WHICH REFERENCE MAY BE MADE IN NATIONAL REGULATIONS.

ISO/CEN PARALLEL PROCESSING



Reference number
ISO/FDIS 22867:2021(E)

iTeh STANDARD PREVIEW (standards.iteh.ai)

ISO/FDIS 22867

<https://standards.iteh.ai/catalog/standards/sist/89da88e7-8940-4832-89c0-a1bf0ca28926/iso-fdis-22867>



COPYRIGHT PROTECTED DOCUMENT

© ISO 2021

All rights reserved. Unless otherwise specified, or required in the context of its implementation, no part of this publication may be reproduced or utilized otherwise in any form or by any means, electronic or mechanical, including photocopying, or posting on the internet or an intranet, without prior written permission. Permission can be requested from either ISO at the address below or ISO's member body in the country of the requester.

ISO copyright office
CP 401 • Ch. de Blandonnet 8
CH-1214 Vernier, Geneva
Phone: +41 22 749 01 11
Email: copyright@iso.org
Website: www.iso.org

Published in Switzerland

Contents

	Page
Foreword.....	iv
Introduction.....	v
1 Scope.....	1
2 Normative references.....	1
3 Terms and definitions.....	1
4 Vibration quantities to be measured and determined.....	2
5 Instrumentation.....	2
5.1 General.....	2
5.2 Accelerometer.....	2
5.3 Fastening of accelerometer.....	2
5.4 Calibration.....	2
5.5 Speed indicator.....	3
6 Measurement direction and location.....	3
7 Test and operating conditions of machine.....	3
8 Measurement and calculation.....	4
8.1 General.....	4
8.2 Validity of measured data.....	5
9 Information to be reported.....	5
10 Declaration and verification of vibration values.....	6
Annex A (normative) Chain-saws.....	8
Annex B (normative) Brush-cutters, grass-trimmers and hand-held edgers.....	12
Annex C (normative) Pole-mounted powered pruners.....	16
Annex D (normative) Hedge trimmers.....	19
Annex E (normative) Garden blowers/vacuums.....	24
Annex F (informative) Summary of results from interlaboratory tests (2007-2008) on a chain-saw, brush saw and grass-trimmer.....	28
Annex ZA (informative) Relationship between this International Standard and the requirements of EU Directive 2006/42/EC aimed to be covered.....	29
Bibliography.....	30

Foreword

ISO (the International Organization for Standardization) is a worldwide federation of national standards bodies (ISO member bodies). The work of preparing International Standards is normally carried out through ISO technical committees. Each member body interested in a subject for which a technical committee has been established has the right to be represented on that committee. International organizations, governmental and non-governmental, in liaison with ISO, also take part in the work. ISO collaborates closely with the International Electrotechnical Commission (IEC) on all matters of electrotechnical standardization.

The procedures used to develop this document and those intended for its further maintenance are described in the ISO/IEC Directives, Part 1. In particular, the different approval criteria needed for the different types of ISO documents should be noted. This document was drafted in accordance with the editorial rules of the ISO/IEC Directives, Part 2 (see www.iso.org/directives).

Attention is drawn to the possibility that some of the elements of this document may be the subject of patent rights. ISO shall not be held responsible for identifying any or all such patent rights. Details of any patent rights identified during the development of the document will be in the Introduction and/or on the ISO list of patent declarations received (see www.iso.org/patents).

Any trade name used in this document is information given for the convenience of users and does not constitute an endorsement.

For an explanation of the voluntary nature of standards, the meaning of ISO specific terms and expressions related to conformity assessment, as well as information about ISO's adherence to the World Trade Organization (WTO) principles in the Technical Barriers to Trade (TBT), see www.iso.org/iso/foreword.html.

This document was prepared by Technical Committee ISO/TC 23, *Tractors and machinery for agriculture and forestry*, Subcommittee SC 17, *Manually portable forest machinery*, in collaboration with the European Committee for Standardization (CEN) Technical Committee CEN/TC 144, *Tractors and machinery for agriculture and forestry*, in accordance with the Agreement on technical cooperation between ISO and CEN (Vienna Agreement).

This third edition cancels and replaces the second edition (ISO 22867:2011), which has been technically revised.

The main changes compared to the previous edition are as follows:

- the scope has been expanded to include hand-held edgers;
- [Clause 9](#) (Information to be reported) has been amended to include “method used for in situ check of the instrumentation system”;
- the accelerometer position for pole-mounted powered pruners and long-reach hedge trimmers has been newly defined to better reflect handling of the machine in use;
- the engine speed tolerance for the operation mode “full load” for chain-saws has been broadened from $3,5 \text{ s}^{-1}$ to $4,5 \text{ s}^{-1}$, to account for feasibility when cutting wood;
- hand-held edgers have been included in [Annex B](#);
- the definition of the position of the accelerometer on the front handle of pole mounted pruners in [Annex C](#) has been improved and [Figure C.1](#) has been modified accordingly;
- the definition of the position of the accelerometer on the front handle of long reach hedge trimmers in [Annex D](#) has been improved and [Figure D.3](#) has been modified accordingly.

Any feedback or questions on this document should be directed to the user's national standards body. A complete listing of these bodies can be found at www.iso.org/members.html.

Introduction

This document is a type-C standard as stated in ISO 12100:2010.

This document is of relevance, in particular, for the following stakeholder groups representing the market players with regard to machinery safety:

- machine manufacturers (small, medium and large enterprises);
- health and safety bodies (regulators, accident prevention organisations, market surveillance, etc.)

Others can be affected by the level of machinery safety achieved with the means of the document by the above-mentioned stakeholder groups:

- machine users/employers (small, medium and large enterprises);
- machine users/employees (e.g. trade unions, organizations for people with special needs);
- service providers, e. g. for maintenance (small, medium and large enterprises);
- consumers (in case of machinery intended for use by consumers).

The above-mentioned stakeholder groups have been given the possibility to participate at the drafting process of this document. The machinery concerned and the extent to which hazards, hazardous situations or hazardous events are covered are indicated in the Scope of this document.

When requirements of this type-C standard are different from those which are stated in type-A or -B standards, the requirements of this type-C standard take precedence over the requirements of the other standards for machines that have been designed and built according to the requirements of this type-C standard.

The vibration test code specified in this document is based on ISO 20643:2008, which gives general specifications for the measurement of the vibration emission of hand-held machinery. It differs from ISO 20643:2008 in the number of operators required to be involved in the test, with ISO 20643:2008 requiring at least three operators and this document only one. Another difference is that this document primarily positions the transducers next to the hand in the area between the thumb and the index finger, where they present the least disturbance to the operator gripping the machine.

The determination of vibration characteristics is primarily used for

- manufacturer's declarations,
- comparing data between machines in the machine family concerned,
- development work at the design stage, and
- the estimation of the vibration risk considering the specific conditions (parameters).

The use of this vibration test code ensures reproducibility of the determination of the vibration characteristics. Measurements made during particular operating modes are of interest for assessment of the vibration exposure, for example, over a typical working day.

The work cycles chosen for this test code are based on the following considerations of application:

- a) chain-saws with an engine displacement of $< 80 \text{ cm}^3$ are used for various operations, including felling, bucking and delimiting;
- b) chain-saws with an engine displacement of $\geq 80 \text{ cm}^3$ are normally used for felling and bucking.

Delimiting causes the saw to run at racing speed; therefore, racing is included only for saws with an engine displacement $< 80 \text{ cm}^3$.

ISO/FDIS 22867:2021(E)

For brush-cutters, grass-trimmers, hedge-trimmers and pole-mounted powered pruners, the cutting mode (full load) is estimated to be valid only for short periods, and racing and idling are the two dominant modes. Moreover, the cutting mode has also been found to be diverse and not able to be performed under repeatable conditions.

For grass-trimmers, the full-load and racing modes are integrated into a single mode, owing to the loading effect of the flexible line.

For brush-cutters, hedge-trimmers, edgers and pole-mounted powered pruners, it is not possible to simulate the full-load mode in a feasible way, since there are no constant load conditions comparable to those of chain-saws. Since the operating mode “racing” is the worst case, it is taken as being representative.

For garden-blowers, full load and idling are the two dominant modes.

In either of these cases, transport and other tasks between operations cause the machine to run at idling. Experience has led to the conclusion that equal duration for the different working modes is a good estimation of daily exposure. The values obtained are values intended to be representative of the average of typical vibration magnitudes in real-world use of the machines. However, the actual magnitudes varies considerably from time to time and depends on many factors, including operator, task and cutting attachment. The state of maintenance of the machine itself might also be of importance.

iTeh STANDARD PREVIEW (standards.iteh.ai)

[ISO/FDIS 22867](https://standards.iteh.ai/catalog/standards/sist/89da88e7-8940-4832-89c0-a1bf0ca28926/iso-fdis-22867)

<https://standards.iteh.ai/catalog/standards/sist/89da88e7-8940-4832-89c0-a1bf0ca28926/iso-fdis-22867>

Forestry and gardening machinery — Vibration test code for portable hand-held machines with internal combustion engine — Vibration at the handles

CAUTION — Some of the test procedures specified in this document involve processes which could lead to a hazardous situation. Any person performing tests in accordance with this document shall be appropriately trained in the type of work to be carried out.

1 Scope

This document specifies a vibration test code for determining, efficiently and under standardized conditions, the magnitude of vibration at the handles of portable hand-held, internal-combustion-engine-powered forest and garden machinery, including chain-saws, brush-cutters, grass-trimmers, edgers, pole-mounted powered pruners, hedge-trimmers and garden-blowers.

Although the magnitudes measured are obtained in an artificial operation, they nevertheless give an indication of the values to be found in a real work situation.

Vibration test codes, as described in this document, enable the manufacturer to verify the effort regarding low vibration design.

2 Normative references (standards.iteh.ai)

The following documents are referred to in the text in such a way that some or all of their content constitutes requirements of this document. For dated references only the edition cited applies. For undated references, the latest edition of the referenced document (including any amendments) applies.

ISO 5349-2:2001, *Mechanical vibration — Measurement and evaluation of human exposure to hand-transmitted vibration — Part 2: Practical guidance for measurement at the workplace*

ISO 6531:2017, *Machinery for forestry — Portable chain-saws — Vocabulary*

ISO 7112:2018, *Machinery for forestry — Portable brush-cutters and grass-trimmers — Vocabulary*

ISO 7293:1997, *Forestry machinery — Portable chain saws — Engine performance and fuel consumption*

ISO 8041-1:2017, *Human response to vibration — Measuring instrumentation — Part 1: General purpose vibration meters*

ISO 8893:1997, *Forestry machinery — Portable brush-cutters and grass-trimmers — Engine performance and fuel consumption*

ISO 12100:2010, *Safety of machinery — General principles for design — Risk assessment and risk reduction*

ISO 16063-1:1998, *Methods for the calibration of vibration and shock transducers — Part 1: Basic concepts*

ISO 20643:2008, *Mechanical vibration — Hand-held and hand-guided machinery — Principles for evaluation of vibration emission*

3 Terms and definitions

For the purposes of this document, the terms and definitions given in ISO 6531:2017, ISO 7112:2018, ISO 12100:2010 and ISO 20643:2008 apply.

ISO and IEC maintain terminological databases for use in standardization at the following addresses:

- ISO Online browsing platform: available at <https://www.iso.org/obp>
- IEC Electropedia: available at <http://www.electropedia.org/>

4 Vibration quantities to be measured and determined

The quantities to be measured are the frequency-weighted accelerations in the three perpendicular directions, a_{hw_x} , a_{hw_y} and a_{hw_z} .

The quantities to be determined are the vibration total values, a_{hv} , and the equivalent vibration total values, $a_{hv,eq}$, for each handle. See the calculations in [Annexes A](#) to [E](#).

NOTE Mathematically, a_{hv} is the root sum of the squares of the three root-mean-square (r.m.s.) single-axis acceleration values of the frequency-weighted hand transmitted vibration values a_{hw_x} , a_{hw_y} and a_{hw_z} .

5 Instrumentation

5.1 General

The vibration measurement system shall be in accordance with ISO 8041-1:2017.

5.2 Accelerometer

The total mass of the vibration accelerometer giving the acceleration in the three directions at each measuring position shall be as low as possible, and shall not in any case exceed 25 g, including the mounting but excluding the cable. For further information, see ISO 5349-2:2001, 6.1.5.

NOTE The accelerometer is a sensitive element intended to pick up the vibration and to convert it into electrical signals. A tri-axial accelerometer permits simultaneous measurements in the x, y and z axes.

5.3 Fastening of accelerometer

The accelerometer shall be mounted firmly on the handle by means of a fastening device, in accordance with ISO 5349-2:2001.

For measurement on handles with resilient covers (e.g. cushioned handle), mount the accelerometer in accordance with ISO 5349-2:2001, 6.1.4.2, and perform one or the other of the following actions:

- remove the resilient material from the area beneath the transducers;
- fix the transducers using a force which fully compresses the resilient material.

Mountings shall be in accordance with ISO 5349-2:2001, D.2.2 and D.2.3. The method given in ISO 5349-2:2001, D.2.4, shall not be used.

5.4 Calibration

The accelerometer shall be calibrated in accordance with ISO 16063-1:1998.

The whole measuring chain, including the accelerometer, shall be checked before and after a sequence of measurements using a calibrator which produces known accelerations at a known frequency. These in-situ checks shall be carried out in accordance with ISO 8041-1:2017.

5.5 Speed indicator

The rotational frequency of the engine shall be measured with an accuracy of $\pm 1,0$ % of the reading. The speed indicator and its engagement with the machine shall not affect the operation of the machine under test.

6 Measurement direction and location

Measurements shall be made at each hand-grip at which the operator normally holds the machine. Measurements shall be made simultaneously in the three directions x , y and z .

The centre of gravity of the accelerometer shall be positioned as close as possible to, but at a maximum distance of 20 mm from the handle contour. One of the axes of the accelerometer shall be parallel to the axis of the handle.

The position of the accelerometer shall be as near as possible to the hand without obstructing normal grip.

NOTE The specific conditions for each type of machine are given in [Annexes A to E](#).

7 Test and operating conditions of machine

Measurements shall be carried out on a new machine, featuring standard equipment as provided by the manufacturer, and with the fuel and oil tank(s) at least half-filled.

The engine shall be run-in prior to the test according to the manufacturer's recommendations. The engine shall be at a stable normal operating temperature before the test is commenced.

The carburettor shall be set, where applicable, according to the instructions of the manufacturer.

Unless otherwise specified, the engine speed for all test modes shall be kept constant to within $\pm 3,5$ s^{-1} during testing. No alteration to the initial settings is permitted once measurements have commenced. If adjustment becomes necessary, the test shall be restarted after the adjustment.

The measured vibration of the machine is influenced by the operator. The operator shall therefore be skilled and able to operate the machine properly. The machine shall be held in a manner consistent with day-long use of the machine. Hand-held machines, except those suspended by harness, shall be held so that there is no contact with the operator's body during measurements.

A test to obtain the required data for a given operating mode shall consist of a minimum of four measurements, with a short break and a significant change of engine speed (to idling or racing speed, as applicable) between measurements. Stable speed conditions (constant to within $\pm 3,5$ s^{-1}) shall be obtained before testing is continued.

At least four separate periods of vibration data shall be obtained, totalling at least 20 s.

Each signal duration used shall be at least 2 s, during which the engine speed shall be maintained within $\pm 3,5$ s^{-1} (unless otherwise specified).

The measurements shall be continued until the validity requirements given in [Clause 8](#) are fulfilled.

The collection of data for the different operating modes need not be carried out in any particular sequence.

NOTE The specific conditions for each type of machine are given in [Annexes A to E](#).

8 Measurement and calculation

8.1 General

The following measurements and calculations shall be made and are generally performed in the sequence given here and as illustrated by [Figure 1](#).

- Measure the weighted acceleration of an operating mode in the three directions, $a_{hw_x,J}$, $a_{hw_y,J}$ and $a_{hw_z,J}$, for the left and right handles, where J is the operating mode idling (Id), full load (Fl) or racing (Ra).
- Calculate the root sum of squares of accelerations a_{hwJ} of the three directions x , y and z for the operating mode selected.
- Repeat a) and b) at least three more times.
- Calculate the arithmetic mean of the operating mode, \bar{a}_{hwJ} .
- Repeat a), b) and d) until the coefficient of variation C_v and the standard deviation s_{n-1} conform with the requirements of [8.2](#).
- Perform a) to e) for the remaining operating modes in accordance with the annex applicable to the type of machine.
- Calculate the equivalent vibration total value, $a_{hw,eq}$, for each handle in accordance with the annex applicable to the type of machine.
- Determine the declared value according to [Clause 10](#).

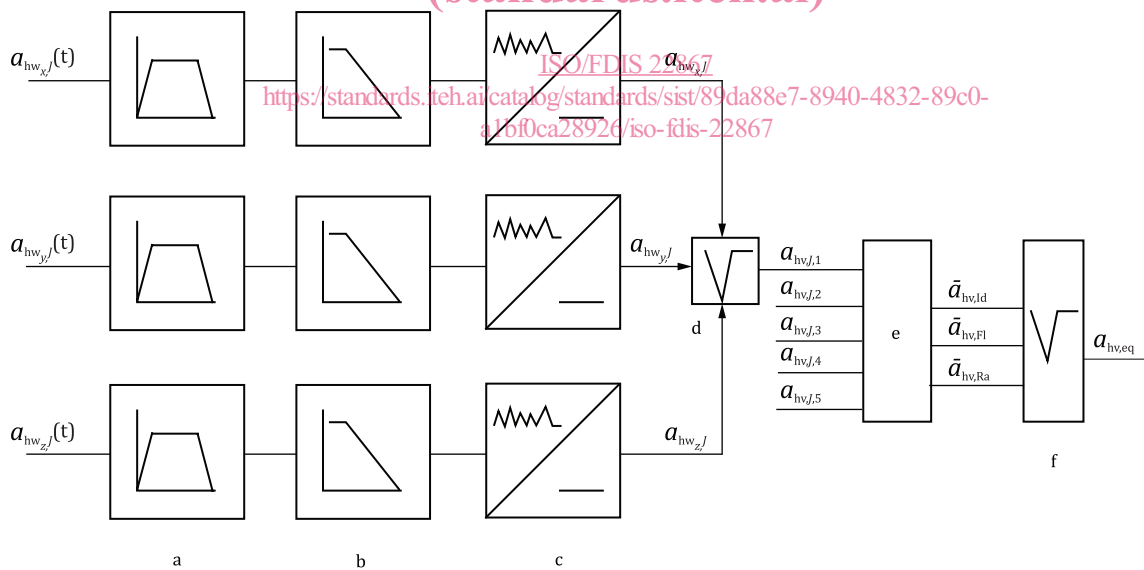

Key

- Band pass filter.
- Frequency weighting filter.
- Root mean square (r.m.s).
- See Note to [Clause 4](#).
- Arithmetic mean for each operating mode.
- See [Annexes A](#) to [E](#) for calculation of $a_{hw,eq}$.

Figure 1 — Sequence of measurement and calculation of vibration data from the applicable operating modes

8.2 Validity of measured data

The measured data for every combination of handle and operating mode shall be considered valid when either

- a) the coefficient of variation, C_v , of the consecutive weighted values is less than 0,3, or
- b) the standard deviation, s_{n-1} , is less than 0,4 m/s².

If C_v is greater than 0,15 or if s_{n-1} is greater than 0,3 m/s², the measurements shall be checked for error before the data are accepted. See ISO 20643:2005, Annex B, for possible causes of error. If the measured values for a combination of handle and operating mode do not meet either criterion a) or b), then measurements and calculations with the non-complying combination shall be repeated until one or the other of these validity criteria is met [see 8.1 e)].

The coefficient of variation, C_v , of a test series is the ratio between the standard deviation, s_{n-1} , of the series of measurement values and the mean value, \bar{x} of the series, determined by [Formula \(1\)](#):

$$C_v = \frac{s_{n-1}}{\bar{x}} \quad (1)$$

with s_{n-1} calculated using [Formula \(2\)](#):

$$s_{n-1} = \sqrt{\frac{1}{n-1} \sum_{i=1}^n (x_i - \bar{x})^2} \quad (2)$$

and \bar{x} calculated using [Formula \(3\)](#):

$$\bar{x} = \frac{1}{n} \sum_{i=1}^n x_i \quad (3)$$

where

- x_i is the i-th value measured;
- n is the number of measurement values.

9 Information to be reported

The following information shall be compiled and reported for all measurements made in accordance with this document.

- a) Machine under test:
 - 1) description of machine, including engine displacement, manufacturer, type and serial number, type of cutting equipment (where applicable);
 - 2) operating conditions, in accordance with [Table 1](#).
- b) Work piece, where applicable.
- c) Instrumentation:
 - 1) equipment used for the measurements, including name, type, serial number and manufacturer;
 - 2) methods used to fasten accelerometers;
 - 3) method used to calibrate the instrumentation system;
 - 4) method used for in situ check of the instrumentation system;

- 5) date and place of most recent calibration of accelerometer calibrator.
- d) Vibration and other data:
 - 1) location of accelerometer positions (a sketch may be included, if necessary);
 - 2) measurement values and arithmetic mean values for each handle and cutting attachment (where applicable) in accordance with [Table 1](#);
 - 3) remarks, if any;
 - 4) air temperature;
 - 5) date and place of measurements.

Table 1 — Table for reporting determined vibration total values and calculation of their arithmetic means for each handle

Operating mode	Calculated data and validity criteria	Operating engine speed s^{-1}	Specified handle				
			Test no.				
•	•	•	1	2	3	4	<i>n</i>
Idling (Id)	$a_{hv,Id}$ (m/s ²)						
•	$\bar{a}_{hv,Id}$ (m/s ²)						
•	s_{n-1} (m/s ²)						
•	C_v						
Full load (Fl) ^a	$a_{hv,Fl}$ (m/s ²)						
•	$\bar{a}_{hv,Fl}$ (m/s ²)						
•	s_{n-1} (m/s ²)						
•	C_v						
Racing (Ra) ^a	$a_{hv,Ra}$ (m/s ²)						
•	$\bar{a}_{hv,Ra}$ (m/s ²)						
•	s_{n-1} (m/s ²)						
•	C_v						

The vibration total values a_{hv} are determined and recorded, and their arithmetic mean, \bar{a}_{hv} is calculated until the coefficient of variation, C_v , is less than 0,3, or the standard deviation, s_{n-1} , is less than 0,4 m/s².
 If C_v is greater than 0,15 or if s_{n-1} is greater than 0,3 m/s², the measurements shall be checked for error before the data are accepted.
 The calculation of arithmetic mean \bar{a}_{hv} is based on at least four determinations of the vibration total value a_{hv} .
 The values for the arithmetic mean ($\bar{a}_{hv,Id}$, $\bar{a}_{hv,Fl}$ and $\bar{a}_{hv,Ra}$) are used to calculate the equivalent vibration total values $a_{hv,eq}$.

^a According to the test procedures for the specific machine type given in [Annexes A to E](#).

10 Declaration and verification of vibration values

The declaration shall include a reference to this document. Deviations, if any, shall be indicated.

Equivalent vibration total values, $a_{hv,eq}$, calculated according to [Annexes A to E](#), shall be used for the declaration of the vibration emission values. The uncertainty, *K*, shall also be given.

The total vibration value for the applicable operating modes (idling, full load and racing) shall be made available on request.