

INTERNATIONAL
STANDARD

ISO
6055

Fourth edition

**Industrial trucks — Overhead guards
— Specification and testing**

*Chariots de manutention — Protège-conducteurs — Spécifications et
essais*

iTeh STANDARD PREVIEW
(standards.iteh.ai)

ISO/PRF 6055

<https://standards.iteh.ai/catalog/standards/sist/83014317-3274-4db3-9407-84c927c32b83/iso-prf-6055>

PROOF / ÉPREUVE



Reference number
ISO 6055:2023(E)

© ISO 2023

iTeh STANDARD PREVIEW
(standards.iteh.ai)

ISO/PRF 6055

<https://standards.iteh.ai/catalog/standards/sist/83014317-3274-4db3-9407-84c927c32b83/iso-prf-6055>



COPYRIGHT PROTECTED DOCUMENT

© ISO 2023

All rights reserved. Unless otherwise specified, or required in the context of its implementation, no part of this publication may be reproduced or utilized otherwise in any form or by any means, electronic or mechanical, including photocopying, or posting on the internet or an intranet, without prior written permission. Permission can be requested from either ISO at the address below or ISO's member body in the country of the requester.

ISO copyright office
CP 401 • Ch. de Blandonnet 8
CH-1214 Vernier, Geneva
Phone: +41 22 749 01 11
Email: copyright@iso.org
Website: www.iso.org

Published in Switzerland

Contents

	Page
Foreword.....	iv
1 Scope.....	1
2 Normative references.....	1
3 Terms and definitions.....	1
4 Requirements for overhead guards on ride-on trucks.....	2
4.1 General.....	2
4.2 Protected area.....	2
4.3 Dimensions.....	3
4.4 Testing.....	4
4.4.1 General.....	4
4.4.2 Dynamic test.....	4
4.4.3 Impact drop test.....	6
4.4.4 Transparent material.....	8
4.4.5 Operators' leg/foot protection test.....	8
4.5 Performance requirements.....	8
5 Requirements for industrial variable-reach trucks with operator position not protected by the boom.....	11
5.1 General.....	11
5.2 Protective structures.....	11
5.3 Dimensions.....	12
5.4 Testing.....	12
5.4.1 General.....	12
5.4.2 Falling objects test.....	12
5.4.3 Overturning test.....	12
6 Information for maintenance.....	12
Bibliography.....	13

Foreword

ISO (the International Organization for Standardization) is a worldwide federation of national standards bodies (ISO member bodies). The work of preparing International Standards is normally carried out through ISO technical committees. Each member body interested in a subject for which a technical committee has been established has the right to be represented on that committee. International organizations, governmental and non-governmental, in liaison with ISO, also take part in the work. ISO collaborates closely with the International Electrotechnical Commission (IEC) on all matters of electrotechnical standardization.

The procedures used to develop this document and those intended for its further maintenance are described in the ISO/IEC Directives, Part 1. In particular, the different approval criteria needed for the different types of ISO documents should be noted. This document was drafted in accordance with the editorial rules of the ISO/IEC Directives, Part 2 (see www.iso.org/directives).

Attention is drawn to the possibility that some of the elements of this document may be the subject of patent rights. ISO shall not be held responsible for identifying any or all such patent rights. Details of any patent rights identified during the development of the document will be in the Introduction and/or on the ISO list of patent declarations received (see www.iso.org/patents).

Any trade name used in this document is information given for the convenience of users and does not constitute an endorsement.

For an explanation of the voluntary nature of standards, the meaning of ISO specific terms and expressions related to conformity assessment, as well as information about ISO's adherence to the World Trade Organization (WTO) principles in the Technical Barriers to Trade (TBT), see www.iso.org/iso/foreword.html.

This document was prepared by Technical Committee ISO/TC 110, *Industrial trucks*, Subcommittee SC 2, *Safety of powered industrial trucks*.

This fourth edition cancels and replaces the third edition (ISO 6055:2004), which has been technically revised.

The main changes are as follows:

- for stand-on controlled trucks, vertical clearance has been increased, from the platform to the underside of the overhead guard;
- requirements for rough terrain variable-reach trucks have been excluded;
- specifications and test requirements have been added for transparent material used to bridge openings in the top of the overhead guard structure not conforming to [4.3.1](#);
- information for use in relation to the inspection of structure and inspection and care of transparent material has been added.

Any feedback or questions on this document should be directed to the user's national standards body. A complete listing of these bodies can be found at www.iso.org/members.html.

Industrial trucks — Overhead guards — Specification and testing

1 Scope

This document specifies the requirements and testing of overhead guards, operator's leg(s)/feet protection for industrial trucks and overturning testing of industrial variable-reach trucks with operator position not protected by the boom (hereafter referred to as "trucks") requiring an overhead guard according to ISO 3691-1 and ISO 3691-2.

This document is not applicable to rough-terrain variable-reach trucks and slewing rough-terrain variable-reach trucks.

2 Normative references

The following documents are referred to in the text in such a way that some or all of their content constitutes requirements of this document. For dated references, only the edition cited applies. For undated references, the latest edition of the referenced document (including any amendments) applies.

ISO 3164, *Earth-moving machinery — Laboratory evaluations of protective structures — Specifications for deflection-limiting volume*

ISO 3449, *Earth-moving machinery — Falling-object protective structures — Laboratory tests and performance requirements*

ISO 3471, *Earth-moving machinery — Roll-over protective structures — Laboratory tests and performance requirements*

ISO 3691-1:2011, *Industrial trucks — Safety requirements and verification — Part 1: Self-propelled industrial trucks, other than driverless trucks, variable-reach trucks and burden-carrier trucks*

ISO 3691-1:2011/AMD1:2020, *Industrial trucks — Safety requirements and verification — Part 1: Self-propelled industrial trucks, other than driverless trucks, variable-reach trucks and burden-carrier trucks — Amendment 1*

ISO 3691-2:2016, *Industrial trucks — Safety requirements and verification — Part 2: Self-propelled variable-reach trucks*

ISO 5053-1, *Industrial trucks — Vocabulary — Part 1: Types of industrial trucks*

ISO 5353, *Earth-moving machinery, and tractors and machinery for agriculture and forestry — Seat index point*

ISO 13564-1:2012, *Powered industrial trucks — Test methods for verification of visibility — Part 1: Sit-on and stand-on operator trucks and variable-reach trucks up to and including 10 t capacity*

ISO 16936-1:2020, *Glass in building — Forced-entry security glazing — Part 1: Test and classification by repetitive ball drop*

3 Terms and definitions

For the purposes of this document, the terms and definitions given in ISO 5053-1, ISO 3691-1, ISO 3691-2 and ISO 5353 and the following apply.

ISO and IEC maintain terminology databases for use in standardization at the following addresses:

- ISO Online browsing platform: available at <https://www.iso.org/obp>
- IEC Electropedia: available at <https://www.electropedia.org/>

3.1

overhead guard

device fitted to the truck for the purpose of protecting the operator against falling objects

[SOURCE: ISO 3691-2:2016, 3.12]

4 Requirements for overhead guards on ride-on trucks

4.1 General

This clause applies to trucks fitted with masts and industrial variable-reach trucks where the operator position is protected by the boom, i.e. the mast or boom prevents the truck from tipping more than a nominal 90°.

4.2 Protected area

4.2.1 The overhead guard shall extend over the operator when in the normal operating position(s) as defined in ISO 3691-1 and ISO 3691-2 and when the operator is operating the controls as provided by the truck manufacturer. For overhead guards fixed to the mast, this also applies when the mast is tilted. The overhead guard shall not extend beyond the plan view outline of the truck.

The control levers in their neutral position, the pedals in their released condition and the steering wheel are considered protected if they do not project in the direction of the mast more than 150 mm beyond the vertical projection of the outline of the overhead guard onto a horizontal plane; see [Figure 1](#).

Adjustable steering wheel position for the driving mode shall be placed in the centre position. No account is taken of the parking brake lever in its foremost position in relation to the mast.

Dimensions in millimetres

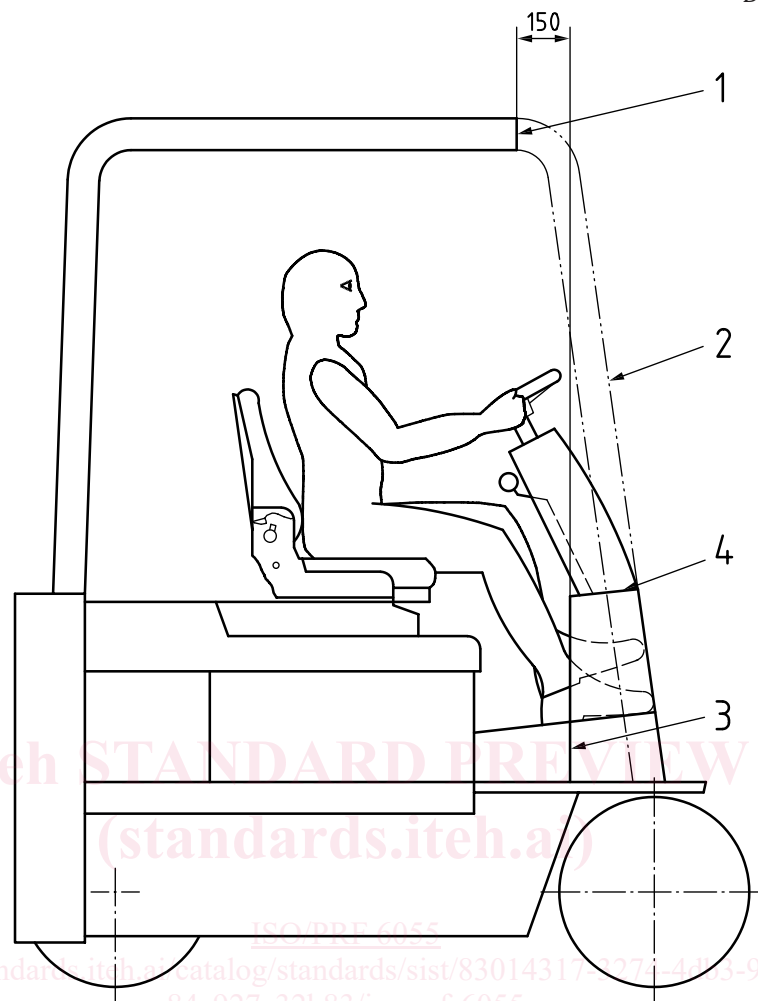
**Key**

- 1 edge of overhead guard
- 2 phantom view of front support
- 3 rear of forward structure
- 4 foot protection structure

Figure 1 — Satisfactory protection by the overhead guard

Any part of the operator's leg or feet, in the normal operating position, that projects more than 150 mm beyond the front of the overhead guard when vertically projected onto a horizontal plane shall be protected by a structure. The test procedure for the structure is described in [4.4.5](#).

4.2.2 Failure of the tilting mechanism shall not directly, or indirectly, cause the operator to be in danger because of the overhead guard.

4.3 Dimensions

4.3.1 Openings in the top of the overhead guard shall not permit a sphere larger than 150 mm diameter to pass through the openings.

4.3.2 If transparent material (for example glass) is used to bridge openings in the top of the overhead guard structure that do not conform to [4.3.1](#) the transparent material shall conform to [4.4.4](#).

4.3.3 For trucks on which the operator is seated, the vertical clearance from the seat index point (SIP) in accordance with ISO 5353 to the underside of the section of the overhead guard under which the operator's head is located when the operator is in the normal operating position, shall not be less than 903 mm.

NOTE 1 The distance of 903 mm (SIP) provides 24 mm clearance for the 95th percentile operator (1 905 mm) according to ISO 3411.

4.3.4 For trucks on which the operator stands, the vertical clearance, from the platform where the operator stands to the underside of the section of the overhead guard under which the operator's head is located when the operator is in the normal operating position, shall not be less than 1 905 mm.

4.3.5 For applications requiring a reduced height overhead guard, with a clearance below what is specified in [4.3.3](#) and [4.3.4](#), the manufacturer may reduce the vertical clearance for the operator's head under the overhead guard.

Where there is reduced vertical clearance, information shall be provided with the overhead guard specifying any limits (for example height of operator) associated with trucks on which the overhead guard is fitted.

NOTE 1 Guidance on operator height is provided in ISO 3411:2007, Table 1 and Table 2.

The requirements of [4.5.2](#) shall not be modified for overhead guards with reduced clearance.

4.3.6 Where the manufacturer of the overhead guard has received a request from the user to reduce the risk of falling objects which could pass through the 150 mm opening (see [4.3.1](#)), then the overhead guard shall be constructed with the opening set as necessary based on the information provided by the user.

4.4 Testing

ISO/PRF 6055

<https://standards.iteh.ai/catalog/standards/sist/83014317-3274-4db3-9407-84c927c32b83/iso-prf-6055>

4.4.1 General

4.4.1.1 A dynamic and an impact drop test shall be carried out on an overhead guard fitted to a truck of the type and rated capacity for which it has been designed. Alternatively, the overhead guard may be mounted on a test chassis provided that the mounting characteristics (for example rigidity, dimensional), are the same as on the truck for which it was designed.

4.4.1.2 The same overhead guard and mounting shall be used for both tests. The dynamic test, as described in [4.4.2](#), shall be conducted first, followed by the impact drop test, as described in [4.4.3](#).

4.4.1.3 In the case of specially designed overhead guards fitted to trucks, other means, such as calculation methods that have been verified through tests on comparable overhead guards, may be used to determine conformance to the requirements.

4.4.2 Dynamic test

4.4.2.1 The purpose of this test is to determine the resistance to permanent deflection of the overhead guard.

4.4.2.2 The test object shall be a mass of 45 kg having a square striking face with a side dimension of 300 mm. The striking face shall be timber with a minimum density of 600 kg/m³ and at least 50 mm thick. The corners and edges shall have a radius of 10⁺⁵₀ mm.

4.4.2.3 The test object shall be positioned to drop in free fall with the striking face approximately parallel to the top of the overhead guard, so as not to strike with a corner or an edge. The test object shall be dropped a distance of 1,5 m 10 times.

The first drop shall be from a point with the centre of the test object vertically above the SIP of the operator's seat in accordance with ISO 5353, with the seat in its mid-point of adjustment (see [Figure 2](#)), or for standing operator, vertically above the standing index point (STIP) as determined in ISO 13564-1:2012, Figure 4 [see [Figure 3 a](#)] or [3 b](#)]. The other 9 drops shall be in a clockwise direction with the centre of the test object equally aligned with points equally spaced on a 600 mm diameter circle, the centre point of which is vertically above the SIP of the operator's seat, in its midpoint of adjustment, or above the centre of the standing operator, vertically above the standing index point (STIP).

To consistently orient the 9 drop points, one point shall be in the forward driving direction as described in ISO 3691-1 or established by the manufacturer if the forward driving direction is not defined in ISO 3691-1.

It is recognized that in some positions the centre of the test object can be outside of the edge of the overhead guard when striking. It is permissible to reposition the test object along the same radius line until the centre of the test object can strike the outer edge of the overhead guard [(see [Figure 3 a](#)] or [3 b](#)].

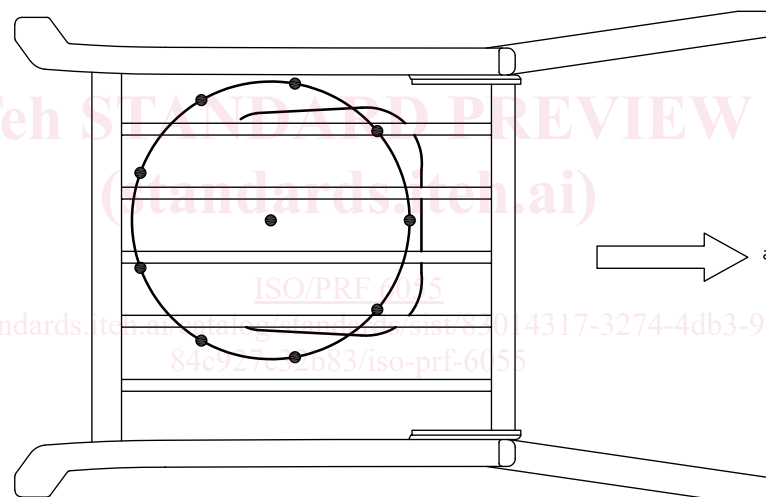

Key

^a Forward travel direction.

Figure 2 — Test object drop location points for sit-on truck above the SIP

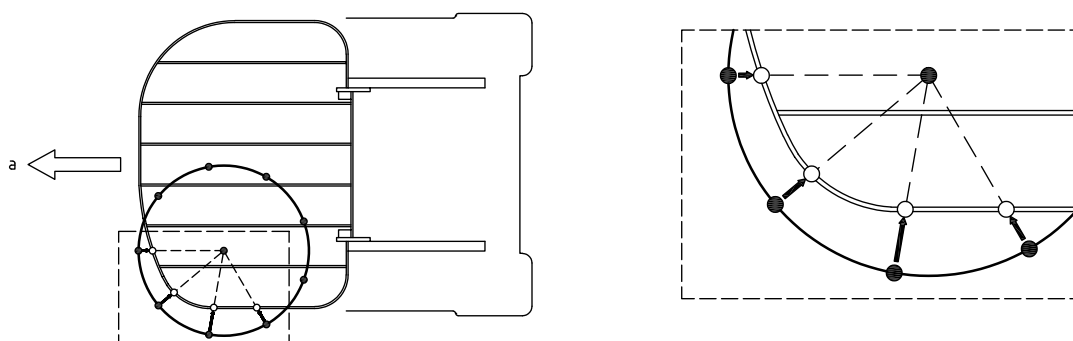

a) Example 1 showing forward travel direction

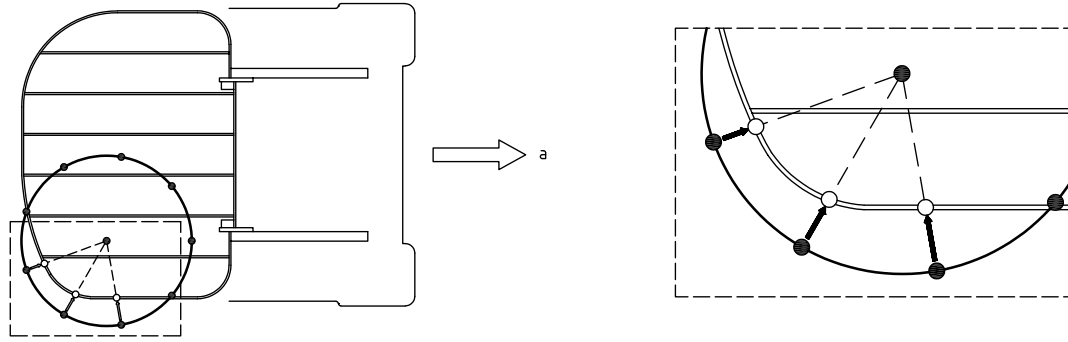

b) Example 2 showing forward travel direction

Key

^a Forward travel direction.

Figure 3 — Test object drop location points for stand-on trucks above STIP

4.4.3 Impact drop test

4.4.3.1 The purpose of this test is to determine the permanent deformation in the worst case configuration as determined by the manufacturer for an overhead guard if struck by a large load, for example packaged timber or paper roll.

If cabin doors are fitted that are not self-closing or are removable, they shall be excluded from the test.

4.4.3.2 The test load shall be composed of (40 to 50) mm thickness × (90 to 100) mm width construction grade timber boards, (3 600 to 3 700) mm long. The complete test load shall not exceed 1 000 mm in width. The (40 to 50) mm × (90 to 100) mm shall be placed with the (90 to 100) mm nominal dimension of the cross-section horizontal. The timber shall be bound together with at least three metal bands, straps or other appropriate means, one approximately in the centre and the others not further than 900 mm from each end.

The test load shall have a minimum mass as specified in [Table 1](#).

A test load of different dimensions and/or materials may be used, provided it results in a test not less severe than that described above.

Table 1 — Overhead guard impact test loads

Truck rated capacity kg	Impact test energy, E_{test}^a J	Minimum mass of test load kg
Under 1 000	3 600	340
1 000 to 1 500	5 400	340
1 501 to 2 500	10 800	680
2 501 to 3 500	21 760	1 360
3 501 to 6 500	32 640	1 360
6 501 to 10 000	43 520	1 360
Over 10 000	48 960	1 360

^a $l_{drop} = E_{test} / (9,8 \times m_{test})$

where

l_{drop} is the drop distance, in m;

m_{test} is the actual mass of the test load, in kg.