



Designation: D7667 – 10

Standard Test Method for Determination of Corrosiveness to Silver by Automotive Spark-Ignition Engine Fuel—Thin Silver Strip Method¹

This standard is issued under the fixed designation D7667; the number immediately following the designation indicates the year of original adoption or, in the case of revision, the year of last revision. A number in parentheses indicates the year of last reapproval. A superscript epsilon (ϵ) indicates an editorial change since the last revision or reapproval.

1. Scope

1.1 This test method covers the determination of the corrosiveness to silver by automotive spark-ignition engine fuel (for example, gasoline), as defined by Specification **D4814** or similar specifications in other jurisdictions, having a vapor pressure no greater than 124 kPa (18 psi) at 37.8°C (100°F) by one of two procedures.

1.1.1 *Procedure A*—Involves the use of a pressure vessel.

1.1.2 *Procedure B*—Involves the use of a vented test tube.

1.2 The values stated in SI units are to be regarded as the standard. The values in parentheses are for information only.

1.3 **WARNING**—Mercury has been designated by many regulatory agencies as a hazardous material that can cause central nervous system, kidney and liver damage. Mercury, or its vapor, may be hazardous to health and corrosive to materials. Caution should be taken when handling mercury and mercury containing products. See the applicable product Material Safety Data Sheet (MSDS) for details and EPA's website—<http://www.epa.gov/mercury/faq.htm>—for additional information. Users should be aware that selling mercury and/or mercury containing products into your state or country may be prohibited by law.

1.4 *This standard does not purport to address all of the safety concerns, if any, associated with its use. It is the responsibility of the user of this standard to establish appropriate safety and health practices and determine the applicability of regulatory limitations prior to use.*

2. Referenced Documents

2.1 *ASTM Standards*:²

D130 Test Method for Corrosiveness to Copper from Petroleum Products by Copper Strip Test

D3241 Test Method for Thermal Oxidation Stability of Aviation Turbine Fuels

D4057 Practice for Manual Sampling of Petroleum and Petroleum Products

D4177 Practice for Automatic Sampling of Petroleum and Petroleum Products

D4814 Specification for Automotive Spark-Ignition Engine Fuel

E1 Specification for ASTM Liquid-in-Glass Thermometers
2.2 *Energy Institute Standards*:³

IP 227 Determination of Corrosiveness to Silver of Aviation Turbine Fuels - Silver Strip Method

2.3 *ASTM Adjuncts*:⁴

Color standard for tube deposit rating (5 aluminum strips)

3. Terminology

3.1 *Abbreviations*:

PTFE = polytetrafluoroethylene

PV = pressure vessel

PVP = pressure vessel procedure

SSCD = silver strip centering device

TSMD = temperature sensing and monitoring device

VITP = vented test tube procedure

4. Summary of Test Method

4.1 A polished, thin silver strip is immersed in 30 mL of the sample being tested, and heated at 50°C (122°F) for 2 h. At the end of the heating period, the silver strip is removed, washed, and the color and tarnish level assessed against the Silver Strip Classifications in **Table 1**.

5. Significance and Use

5.1 Crude petroleum contains sulfur compounds, most of which are removed during refining. However, of the sulfur compounds remaining in the petroleum product or introduced into the fuel during storage and distribution, some can have a corroding action on various metals and this corrosivity is not necessarily related directly to the total sulfur content. The effect can vary according to the chemical types of sulfur

¹ This test method is under the jurisdiction of ASTM Committee **D02** on Petroleum Products and Lubricants and is the direct responsibility of Subcommittee **D02.05.0C** on Color and Reactivity.

Current edition approved Oct. 1, 2010. Published December 2010. DOI: 10.1520/D7667-10.

² For referenced ASTM standards, visit the ASTM website, www.astm.org, or contact ASTM Customer Service at service@astm.org. For *Annual Book of ASTM Standards* volume information, refer to the standard's Document Summary page on the ASTM website.

³ Available from Energy Institute, 61 New Cavendish St., London, WIG 7AR, U.K., <http://www.energyinst.org.uk>.

⁴ Available from ASTM International Headquarters. Order Adjunct No. **ADJD3241**. Original adjunct produced in 1986.

TABLE 1 Silver Strip Classifications

NOTE—Acknowledgement—This table has been reproduced from Standard IP 227.

Classification	Designation	Description
0	No Tarnish	Identical to a freshly-polished strip but may have some very slight loss of luster
1	Slight Tarnish	Faint brown or white discoloration of strip (see 12.2)
2	Moderate Tarnish	Peacock colors such as blue or mauve or medium/dark straw or brown coloration (see 12.2)
3	Slight blackening	Spots and patches of black or gray on surface or uniform thin film of black deposit
4	Blackening	Uniform heavy blackening with or without scaling

compounds present. The silver strip corrosion test is designed to assess the relative degree of corrosivity of a petroleum product towards silver and silver alloys.

5.2 Under some circumstances, reactive sulfur compounds present in automotive spark-ignition engine fuels can tarnish or even corrode silver alloy fuel gauge in-tank sender units or silver-plated bearings (in 2-stroke cycle engines). To minimize or prevent the failure of silver alloy in-tank sender units by tarnish or corrosion, Specification D4814 requires that fuels shall pass a silver strip corrosion test.

6. Apparatus

6.1 Silver Strip Corrosion Pressure Vessel (Procedure A), constructed from stainless steel according to dimensions given in Fig. 1, as described in Test Method D130. The vessel shall be capable of withstanding a test pressure of 700 kPa (100 psi). Alternative designs for the vessel's cap and synthetic rubber gasket may be used provided that the internal dimensions of the vessel are the same as shown in Fig. 1, which allow a nominal 25 by 150 mm (1 by 6 in.) test tube (see 6.2) and the SSCD (see 6.4) to be placed inside the pressure vessel.

6.2 Test Tubes, of borosilicate glass of nominal 25 by 150 mm (1 by 6 in.) dimensions, preferably graduated at 30 mL volume.^{5,6} The internal dimensions shall be checked as acceptable by use of a silver strip (see 7.4). When 30 mL of sample is added to the test tube with the silver strip in it, a minimum of 5 mm of liquid shall be above the top surface of the strip.

6.3 Test Bath, General, whether liquid or solid, the test bath shall be able to maintain the test temperature to within ±1°C (2°F) of the required test temperature. It is recommended that baths be placed inside a fume-hood.

6.3.1 Bath, shall be fitted with suitable supports to hold each test tube (see 6.2) in a vertical position to a depth of about 100 mm (4 in.) as measured from the bottom of the test tube to the bath surface.

6.3.2 Bath Medium, as a liquid bath medium, both water and oil have been found to be satisfactory and controllable at the specified test temperature and duration required by the test procedure.

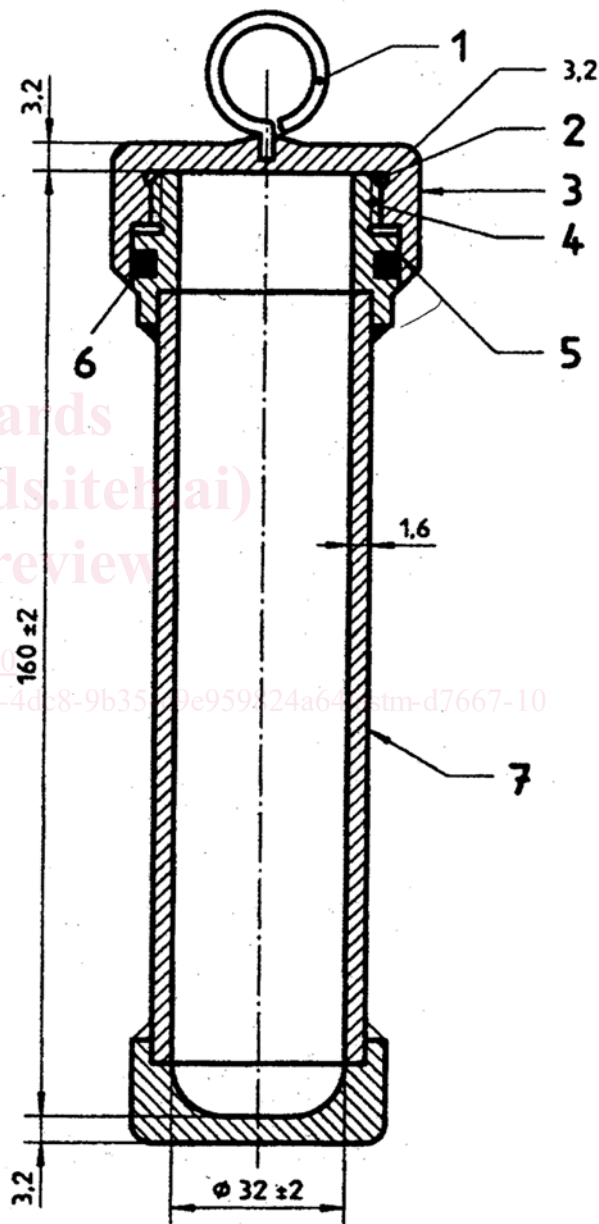

FIG. 1 Pressure Vessel for Silver Strip Corrosion Test – Procedure A

⁵ The sole source of supply of the apparatus known to the committee at this time is Quark Enterprises, Inc., 320 Morton Ave., Rosenhayn, NJ 08352.

⁶ If you are aware of alternative suppliers, please provide this information to ASTM International Headquarters. Your comments will receive careful consideration at a meeting of the responsible technical committee,¹ which you may attend.

6.3.3 *Solid Block Bath*, made of aluminum, shall meet the test temperature control, test duration, and immersion conditions required by the test procedure, and shall be verified, at least annually, for temperature measurement (heat transfer) by running tests on tubes filled with 30 mL of product plus a thin silver strip of the given nominal dimensions, plus a temperature sensor.

6.3.3.1 Wells provided in the solid block bath to accommodate pressure vessels (see Fig. 1) shall be of the following dimensions: ~54 mm (2¹/₈ in.) diameter from top, up to a depth of ~70 mm (2³/₄ in.) continuing with an opening of ~38 mm (1¹/₂ in.) diameter up to a depth of ~140 mm (5¹/₂ in.). An opening of ~8 mm (5¹/₁₆ in.) diameter by ~210 mm (8¹/₄ in.) depth shall be provided in the center of the block for immersion of a metal temperature sensor (connected to a suitable 50 ± 1°C (122 ± 2°F) temperature controller), or thermometer (see 6.5).

6.3.3.2 Wells provided in the solid block bath to accommodate test tubes shall be of the following dimensions: ~20 mm (1¹/₁₆ in.) diameter by ~140 mm (5¹/₂ in.) deep. An opening of ~8 mm (5¹/₁₆ in.) diameter by ~210 mm (8¹/₄ in.) depth shall be provided in the center of the block for immersion of a metal temperature sensor (connected to a suitable 50 ± 1°C (122 ± 2°F) temperature controller), or thermometer (see 6.5).

6.3.3.3 Provide insulation made of ~25.4 mm (1.0 in.) thick fiberglass with aluminum backing (or, similar insulation) to cover all the four sides of the solid block bath.

6.4 *Silver Strip Centering Device (SSCD)*,^{6,7} made of material which is gasoline-compatible at 50°C (122°F) for the duration of the test, such as Acetal Resin, White Nylon 6/6, or PTFE. See details in A1.1 (Assembly View) and A1.2 (Individual Parts View). Length of SSCD inside the test tube is such that the lower edge of the assembled silver strip is about 22 mm (7/8 in.) from the bottom of the test tube.

6.5 *Temperature Sensing and Monitoring Device (TSMD)*, capable of sensing and monitoring the desired test temperature in the bath to within an accuracy of ±1°C (2°F). The ASTM 12C (12F) (see Specification E1) or IP 64C (64F) total immersion thermometer has been found suitable for use in the test. If used, no more than 10 mm (0.4 in.) of the mercury shall extend above the surface of the bath at the test temperature.

6.6 *Timing Device*, electronic or manual, capable of accurately measuring the test duration within the allowable tolerance.

6.7 *Forceps*, with inert tips, stainless steel or polytetrafluoroethylene (PTFE) tips, have been found suitable for use in handling the silver strips.

6.8 *Polishing Board*, 150 by 100 by 3 mm (6 by 4 by 1/8 in.) solid plastic piece having a smooth surface, for placement of silver strip during polishing.

6.9 *Optional Equipment:*

6.9.1 *Refrigerator*, for cooling samples below 5°C (41°F) during storage.

⁷ The sole source of supply of the apparatus known to the committee at this time is K & C Manufacturing, 210 S. Main, Newkirk, OK 74647.

7. Reagents and Materials

7.1 *Wash Solvent*, 2,2,4-trimethylpentane (iso-octane) of minimum 99.75% purity. (**Warning**—Extremely flammable, see 8.1.)

7.2 *Surface Preparation/Polishing Material*, Scouring-pad, approximately 400-grit, made of polyester material that is free of detergents or spongy material, containing aluminum oxide as a scouring-aid.^{6,8}

NOTE 1—Some 400-grit pads are commercially available in the form of 229 by 152 by 9.5 mm (9 by 6 by 3/8 in.) thick pads. For ease of handling and polishing, it is recommended that the pads be cut so that the dimensions of the scouring-pads are about 114 by 38 by 9.5 mm (4 1/2 by 1 1/2 by 3/8 in.).

7.3 *Waterproof Aluminum Oxide Cloth Sanding Sheets or Rolls*,^{6,9} 150-grit.

7.4 *Silver Strips*, Use strips 36.0 to 40.0 mm (1⁷/₁₆ to 1⁹/₁₆ in.) long, 6.25 to 6.35 mm (1⁵/₆₄ to 1/4 in.) wide and 0.526 to 0.541 mm (~1³⁵/₆₄ in.) thick, assaying at 99.9% (m/m) Ag minimum.^{6,10} When necessary, cut, straight and smooth, using a sharp tin-snip or any other metal-cutting device, (such as a heavy-duty ~152 mm (6 in.) shear^{6,11}) approximately 38.0 mm (1 1/2 in.) long strips from the longer strips supplied. Strips may be used repeatedly, but should be discarded when the original shape becomes deformed, or surface shows pitting, scratches or tarnish that cannot be removed by the specified polishing procedure.

7.5 *Ashless Filter Paper or Disposable Gloves or Fingertip Protectors*, for use in protecting the silver strip from coming in contact with the individual during polishing.

8. Hazards

8.1 *Wash Solvent*. (**Warning**— iso-octane: Harmful if inhaled. Vapors may cause flash fire. Keep away from heat, sparks and open flames, and container closed. Use with adequate ventilation. Avoid build-up of vapors and eliminate all sources of ignition, especially non-explosion-proof electrical apparatus and heaters. Avoid prolonged breathing of vapor or spray mist.)

8.2 *Gasoline, (Unleaded or Leaded)*. (**Warning**—Keep away from heat, sparks and open flames, and container closed. Use with adequate ventilation. Avoid build-up of vapors and eliminate all sources of ignition, especially non-explosion-proof electrical apparatus and heaters. Avoid prolonged breathing of vapor or spray mist. Avoid prolonged or repeated skin contact.)

8.3 *Pressure Vessel*, heat and pressure will be built-up in the pressure vessel during the test. After the test, cool and depressurize pressure vessel carefully and fully before opening it for inspection of the silver strip.

⁸ The sole source of supply of the apparatus known to the committee at this time is 3M's "Scotch Brite 86" scouring pads (114 by 38 by 9.5 mm thick cut pieces) were used in the ruggedness study.

⁹ The sole source of supply of the apparatus known to the committee at this time is Part No. 8225A22 (1 1/2 width roll), McMaster Carr Supply Co.

¹⁰ The sole source of supply of the apparatus known to the committee at this time is pre-cut silver strips, C&P Catalyst, PO Box 520984, Tulsa, OK 74152.

¹¹ The sole source of supply of the apparatus known to the committee at this time is Part No. 82818, Micro-mark, 340 Snyder Ave., Berkeley Heights, NJ 07922.

9. Samples and Sample Preparation

9.1 Collect samples according to Practices **D4057** or **D4177** in clean, amber bottles made of borosilicate glass.

9.2 Close containers immediately after filling them to between 70 to 85% of their capacity. Adequate headspace in the container is necessary to provide room for possible thermal expansion during transport.

9.3 Take care during sampling, transportation and storage to protect the samples from exposure to direct sunlight or even diffused light.

9.4 Perform the test as soon as possible after receipt in the laboratory and immediately after opening the container. If necessary, store collected samples in a refrigerator or cold room, at a temperature not exceeding 5°C (41°F).

9.5 If suspended water (that is, haze) is observed in the sample, dry by filtering a sufficient volume of sample through medium rapid qualitative filter-paper, into the prescribed clean, dry test tube. Carry out this operation in a darkened room or under a light-protective shield.

NOTE 2—Contact of the silver strip with water before, during or after completion of the test run will cause staining, making it difficult to evaluate the strips.

10. Preparation of Test Strips

10.1 *Surface Preparation*—To prevent possible surface contamination during preparation, do not allow fingers to come in contact with the silver strip. Wear disposable gloves, finger-tip protectors, or hold the strip in the fingers protected with ashless filter-paper.

10.2 Using a new/unused portion of a small strip of the 400-grit scouring-pad (see **Note 1**) first polish the ends, then the sides of the silver strip giving gentle, unidirectional strokes. Next, gently and unidirectionally, scour the long axis of the silver strip, carrying the stroke beyond the end of the strip before reversing the direction, until both surfaces demonstrate uniform asperities (roughness). Do not polish in a circular motion.

10.3 To restore the original luster of a used silver strip, it may be essential to polish it first with the 150-grit aluminum oxide cloth (using the same technique as that outlined in **10.2**) followed by final polishing with the 400-grit scouring pad.

10.4 Wash the silver strip with wash-solvent (see **7.1**), until it is free from metal dust and other foreign matter. Immediately store in the wash-solvent for use within 1 min.

11. Procedure

11.1 Procedure A—Using a Pressure Vessel (PVP):

NOTE 3—The pressure vessel is used to prevent evaporation of volatile samples such as gasoline during the test procedure, therefore, ensure that the O-ring of the PV is also in a good, usable condition to prevent leakage.

11.1.1 Wearing disposable gloves or other finger protection, insert the polished silver strip taken from the wash solvent, under the clip of the SSCD, up to the ridge (about 4 to 6 mm ($\frac{5}{32}$ to $\frac{7}{32}$ in.)).

11.1.2 Place 30 mL of sample, completely clear and free of any suspended or entrained water (see **9.5**) into a clean and dry 25 by 150 mm (1 by 6 in.) graduated test tube (see **6.2**) and, within 1 min, place the SSCD into the test tube. Note that the

lower edge of the assembled silver strip is about 22 mm ($\frac{7}{8}$ in.) from the bottom of the test tube.

11.1.3 Carefully place the test tube in the pressure vessel, and screw the lid on tightly.

11.1.4 Place the pressure vessel in a bath maintained at $50 \pm 1^\circ\text{C}$ ($122 \pm 2^\circ\text{F}$), and note the time at which this is done.

11.1.5 If more than one sample is to be analyzed at essentially the same time, it is permissible to prepare each pressure vessel in the batch before immersing each one in the bath maintained at $50 \pm 1^\circ\text{C}$ ($122 \pm 2^\circ\text{F}$), provided the elapsed time between the first and last samples is kept to a minimum. Note the time at which this is done.

11.1.6 After 120 ± 2 min for the automotive spark-ignition engine fuels, withdraw the pressure vessel from the bath and immerse in cool water for a few minutes.

11.1.7 Open the pressure vessel carefully in a well-ventilated area, such as a fume-hood, to safely vent any residual pressure that may have built up during the test (**Warning**—Contents may be under pressure.)

11.1.8 Forceps (see **6.7**) may be used to grip the bar of the SSCD and remove it from the test tube. Remove test tube and dispose of contents appropriately.

11.1.9 Wearing disposable gloves or using alternate finger protection, lower the SSCD into wash-solvent such that silver strip is completely immersed. Remove immediately, give a few moments for the solvent to evaporate, then, within 15 min, inspect the strip for evidence of tarnishing or corrosion, with reference to Section **12** and **Table 1**.

11.2 Procedure B—Using a Vented Test Tube (VTTP):

11.2.1 Wearing disposable gloves, or other finger protection, insert the polished silver strip taken from the wash solvent, under the clip of the SSCD, up to the ridge (about 4 to 6 mm ($\frac{5}{32}$ to $\frac{7}{32}$ in.))

11.2.2 Place 30 mL of sample, completely clear and free of any suspended or entrained water (see **9.5**) into a clean and dry 25 by 150 mm (1 by 6 in.) graduated test tube (see **6.2**) and, within 1 min, place the SSCD assembly into the test tube. Note that the lower edge of the assembled silver strip is about 22 mm ($\frac{7}{8}$ in.) from the bottom of the test tube.

11.2.3 Now place the test tube in a bath maintained at $50 \pm 1^\circ\text{C}$ ($122 \pm 2^\circ\text{F}$), and note the time at which this is done.

11.2.4 If more than one sample is to be analyzed at essentially the same time, it is permissible to prepare each sample in the batch before immersing each one in the bath maintained at $50 \pm 1^\circ\text{C}$ ($122 \pm 2^\circ\text{F}$), and note the time at which this is done. Protect the contents of the test tube from strong light during the test (see **Note 4**).

11.2.5 After 120 ± 2 min for the automotive spark-ignition engine fuels, wearing disposable gloves or other finger protection, withdraw the test tube from the bath. Allow test tube to cool slightly. Forceps (see **6.7**) may be used to grip the bar of the SSCD, and remove it from the test tube. Dispose of contents of test tube appropriately.

11.2.6 Wearing disposable gloves or using alternate finger protection, lower the SSCD into wash-solvent such that silver strip is completely immersed. Remove immediately, give a few moments for the solvent to evaporate, then, within 15 min,