International Standard



2593

INTERNATIONAL ORGANIZATION FOR STANDARDIZATION • МЕЖДУНАРОДНАЯ ОРГАНИЗАЦИЯ ПО СТАНДАРТИЗАЦИИ • ORGANISATION INTERNATIONALE DE NORMALISATION

Data communication — 34 pin DTE/DCE interface connector and pin assignments

Transmission des données — Connecteur d'interface ETTD/ETCD à 34 broches et affectation des broches

Second edition — 1984-02-01

iTeh STANDARD PREVIEW
(standards.iteh.ai)

[ISO 2593:1984](https://standards.iteh.ai/catalog/standards/sist/4b566a73-b1d3-467d-bdfb-3fcca157f654/iso-2593-1984)

<https://standards.iteh.ai/catalog/standards/sist/4b566a73-b1d3-467d-bdfb-3fcca157f654/iso-2593-1984>

UDC 681.327.8 : 621.316.541

Ref. No. ISO 2593-1984 (E)

Descriptors : data processing, data transmission, data terminal equipment, electric connectors, connector pins, layout, numbering.

Price based on 5 pages

Foreword

ISO (the International Organization for Standardization) is a worldwide federation of national standards bodies (ISO member bodies). The work of developing International Standards is carried out through ISO technical committees. Every member body interested in a subject for which a technical committee has been authorized has the right to be represented on that committee. International organizations, governmental and non-governmental, in liaison with ISO, also take part in the work.

Draft International Standards adopted by the technical committees are circulated to the member bodies for approval before their acceptance as International Standards by the ISO Council.

International Standard ISO 2593 was developed by Technical Committee ISO/TC 97, *Information processing systems*, and was circulated to the member bodies in November 1981.

ITC STANDARD PREVIEW
(standards.iteh.ai)

It has been approved by the member bodies of the following countries :

Belgium	Germany, F. R.	Romania
Canada	Hungary	South Africa, Rep. of
China	Ireland	Spain
Czechoslovakia	Italy	Sweden
Denmark	Japan	Switzerland
Egypt, Arab Rep. of	Netherlands	United Kingdom
Finland	Poland	USA

<https://standards.iteh.ai/catalog/standards/sist/4b566a73-b1d3-467d-bdfb-3fcca157f654/iso-2593-1984>

The member body of the following country expressed disapproval of the document on technical grounds :

France

This second edition cancels and replaces the first edition (ISO 2593-1973).

Data communication — 34 pin DTE/DCE interface connector and pin assignments

iTeh STANDARD PREVIEW

1 Scope and field of application

This International Standard specifies the assignment of connector pin numbers and certain essential connector dimensions necessary to ensure mechanical compatibility at the interface between Data Terminal Equipment (DTE) and Data Circuit Terminating Equipment (DCE) where CCITT Recommendations V.35 and X.21 bis are applicable.

2 References

CCITT Recommendation V.35, *Data transmission at 48 kbit/s using 60-108 kHz group band circuits.*¹⁾

CCITT Recommendation X.21 bis, *Use on Public Data Networks of Data Terminal Equipment (DTE) which are designed for interfacing to Synchronous V-series Modems.*

MIL Specification MIL-C-28748/-F, *Connector, electrical, rectangular, rack and panel.*

3 Connector

Figures 1 to 5 define the 34 pin interface connector.

Figure 1 illustrates the DTE interface connector which has 34 male contacts and a plug shell. Figure 2 illustrates the DCE interface connector which has 34 female contacts and a receptacle shell. Contact identification lettering is also illustrated in figures 1 and 2. The use of shields and retaining plates of dif-

ferent shape and size from those illustrated is not a violation of this International Standard.

This International Standard does not specify the means for retaining the connector assembly (comprising contact insert, shell and retaining plate or cable adapter).

NOTE — These features are indicated by concentric circles in figures 1, 2 and 3.

This International Standard does not specify the dimensions of the jackscrews. An addendum is in preparation which will specify these dimensions.

Figure 3 illustrates the dimensions for the pin layout.

Figures 4 and 5 specify the dimensions of the pin and mating socket respectively.

NOTES

1 The nominal pin diameter of 1,6 mm is referred to as size 16 in MIL-C-28748/-F.

2 The first edition of this International Standard did not specify all the connector dimensions required to ensure mechanical compatibility. As a result pins with nominal diameters of both 1 mm and 1,6 mm and two different arrangements of plug shell and receptacle shell are now in use in different countries. This International Standard specifies 1,6 mm pins and the particular arrangement of plug shell and receptacle shell described above; where arrangements occur which do not conform with the 1984 edition, adapters may be necessary.

3 The plug shell specified in this International Standard does not contain the optional polarizing pin defined in MIL-C-28748/-F.

1) Manufacturers are advised that there are other CCITT Recommendations for group band modems, viz V.36 and V.37.

4 Pin assignments

The pin assignments shall be as given in the table.

Table — Assignment of pin numbers

Pin*	Function**	CCITT circuit No.	Direction
A	See note 1	—	—
B	Signal ground or common return	102	common
C	Request to send	105	from DTE
D	Ready for sending	106	to DTE
E	Data set ready	107	to DTE
F	Data channel received line signal detector	109	to DTE
H	Connect data set to line or Data terminal ready (see note 2)	108/1 108/2	from DTE from DTE
J	Calling indicator (see note 2)	125	to DTE
K	F ₁	—	—
L	Local loopback (see note 2)	141	from DTE
M	F ₁	—	—
N	Loopback/Maintenance test (see note 2)	140	from DTE
R	Received data A-wire	104	to DTE
T	Received data B-wire	104	to DTE
V	Receiver signal element timing A-wire	115	to DTE
X	Receiver signal element timing B-wire	115	to DTE
Y	Transmitter signal element timing A-wire	114	to DTE
AA	Transmitter signal element timing B-wire	114	to DTE
P	Transmitted data A-wire	103	from DTE
S	Transmitted data B-wire	103	from DTE
U	Transmitter signal element timing A-wire (see note 2)	113	from DTE
Z	F ₂	—	—
W	Transmitter signal element timing B-wire (see note 2)	113	from DTE
BB	F ₂	—	—
CC	F ₃	—	—
DD	F ₄	—	—
EE	F ₃	—	—
FF	F ₄	—	—
HH	N ₁	—	—
JJ	N ₂	—	—
KK	N ₁	—	—
LL	N ₂	—	—
MM	F	—	—
NN	Test indicator (see note 2)	142	to DTE

* N = pin number permanently reserved for national use.

F = pin number reserved for future International Standard and should not be used for national use.

** Subscripts indicate pins which may be associated to form pairs; for example, F₁ on pins K and M form a pair.

NOTES

1: Pin A is assigned for connecting the shields between tandem sections of the shielded interface cable. The shield may be connected either to protective ground or to signal ground at either the DTE or DCE or both in accordance with national regulations.

Signal ground may be further connected to protective ground in accordance with national safety regulations. Caution should be exercised to prevent establishment of ground loops carrying high currents.

2 These functions are not included in CCITT Recommendation V.35 but where implemented on an optional basis the assigned pins should be used.

Dimensions in millimetres

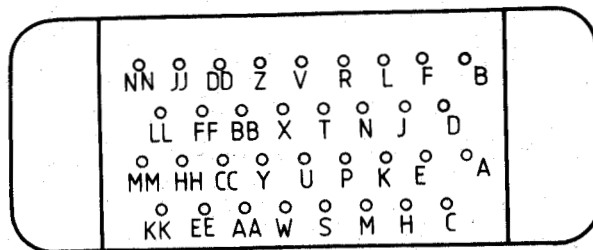

DTE connector face
Contact identification lettering

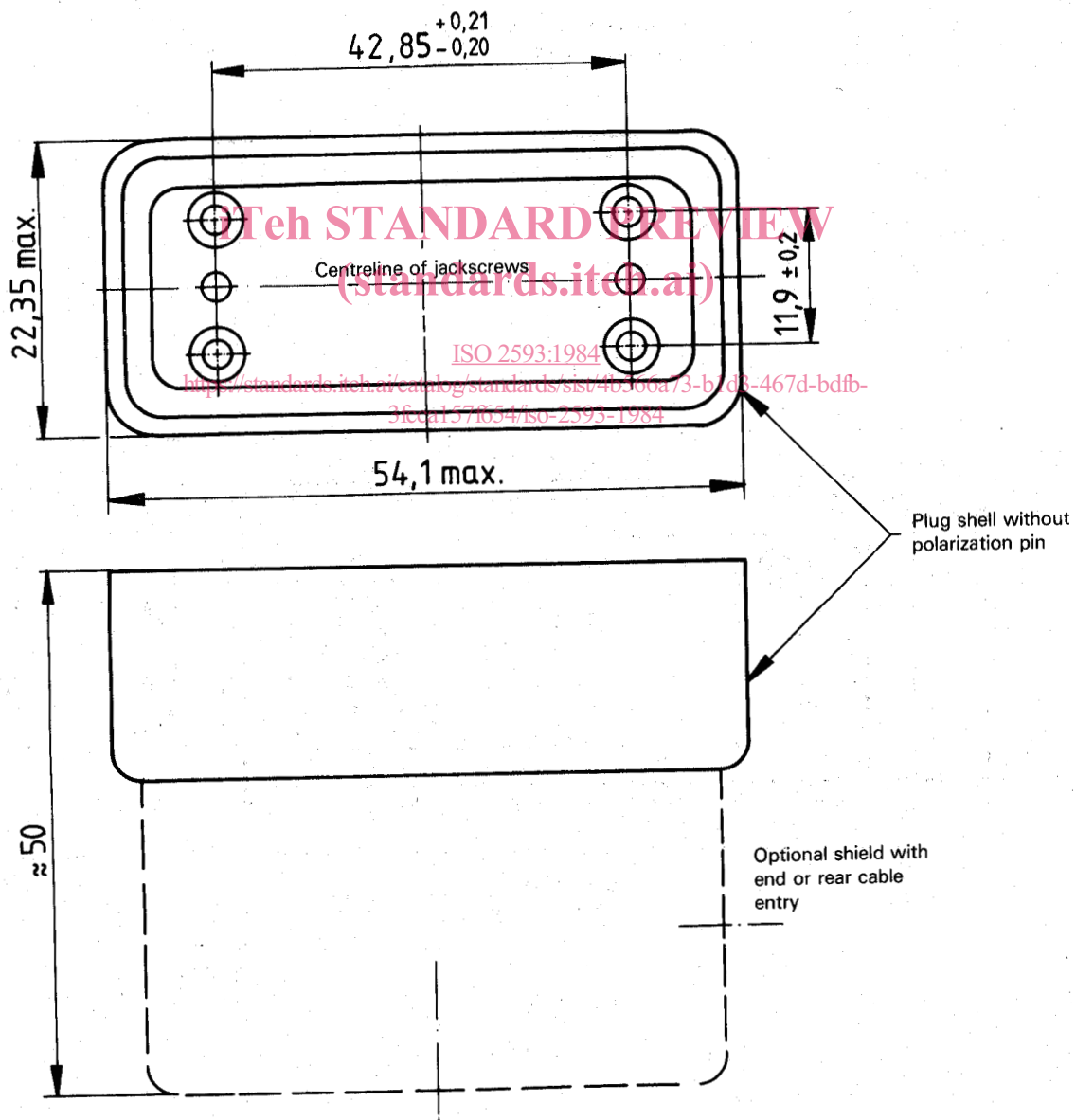
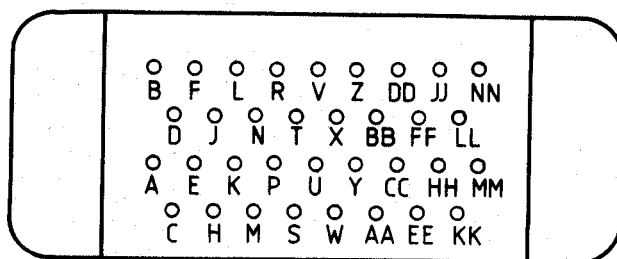

Figure 1 – DTE interface connector

Dimensions in millimetres



DCE connector face
Contact identification lettering

iTeh STANDARD PREVIEW
(standards.iteh.ai)

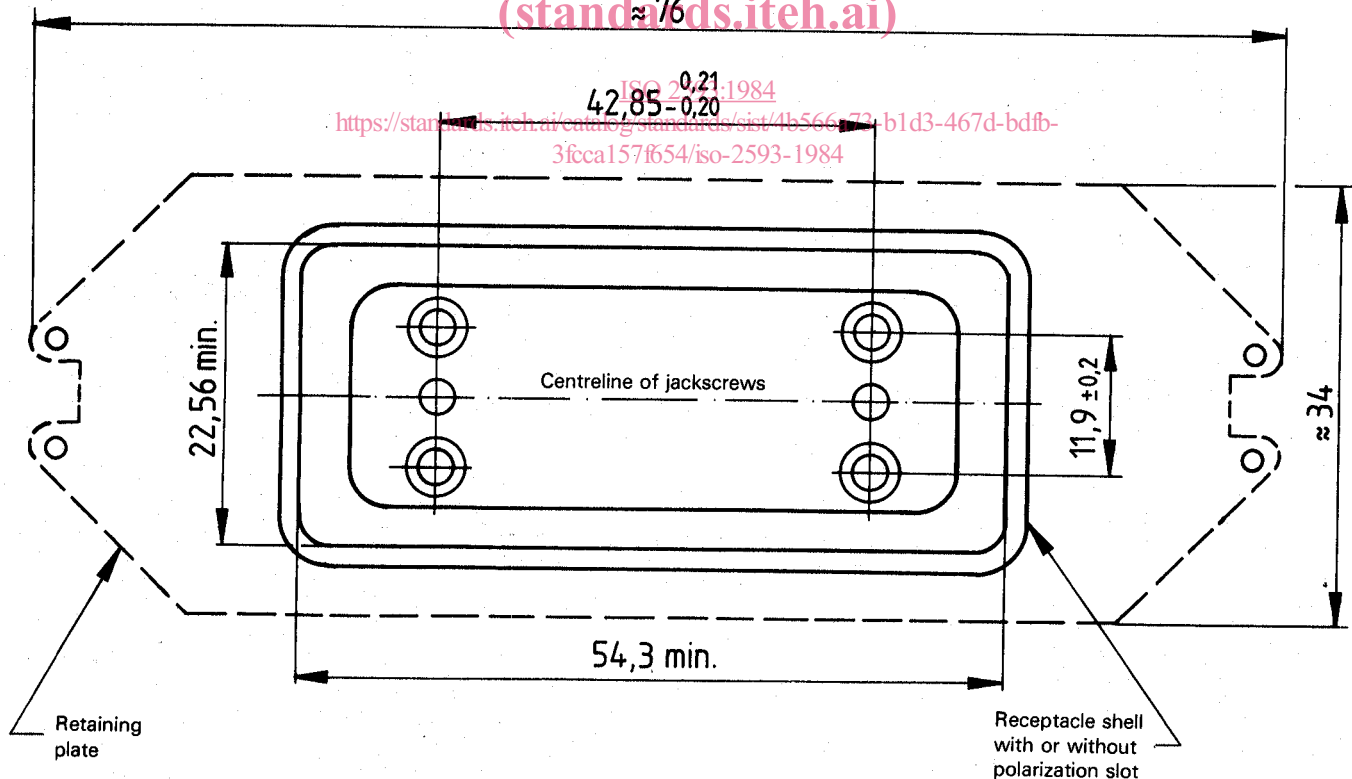
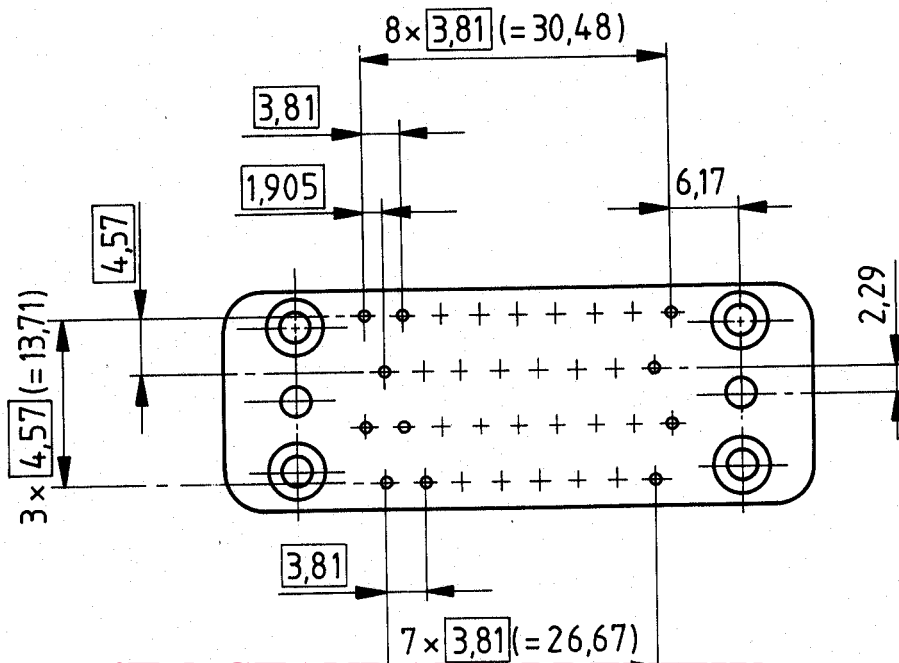

Figure 2 — DCE interface connector

Dimensions in millimetres



iTeh STANDARD PREVIEW
 (standards.iteh.ai)
 Figure 3 — Insert arrangement

ISO 2593:1984

<https://standards.iteh.ai/catalog/standards/sist/4b566a73-b1d3-467d-bdff-3fcca157f654/iso-2593-1984>
 Dimensions in millimetres

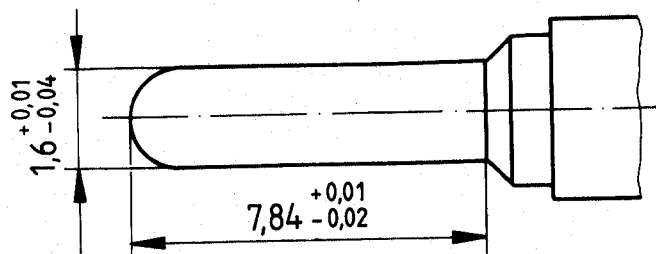

Figure 4 — Male contact

Dimensions in millimetres

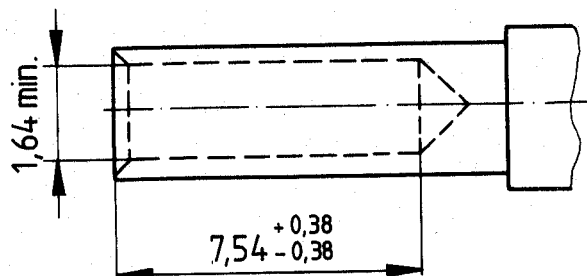

Figure 5 — Female contact

iTeh STANDARD PREVIEW
(standards.iteh.ai)

ISO 2593:1984

<https://standards.iteh.ai/catalog/standards/sist/4b566a73-b1d3-467d-bdfb-3fcca157f654/iso-2593-1984>