



Designation: ~~G20-88(Reapproved2002)~~ Designation: G20 – 10

Standard Test Method for Chemical Resistance of Pipeline Coatings¹

This standard is issued under the fixed designation G20; the number immediately following the designation indicates the year of original adoption or, in the case of revision, the year of last revision. A number in parentheses indicates the year of last reapproval. A superscript epsilon (ϵ) indicates an editorial change since the last revision or reapproval.

1. Scope

1.1 This test method is intended for evaluating the resistance of pipe coating materials when exposed to various concentrations of reagents or suspected soil contaminants. The test serves as a guide to investigators wishing to compare the relative merits of pipe-coating materials in specific environments. The choice of reagents, concentrations, duration of immersion, temperature of test, and properties to be reported are necessarily arbitrary and should be chosen to reflect conditions known to exist along the pipeline right-of-way.

1.2 The values stated in SI units are to be regarded as the standard. The values given in parentheses are for information only.

1.3 *This standard does not purport to address all of the safety concerns, if any, associated with its use. It is the responsibility of the user of this standard to establish appropriate safety and health practices and determine the applicability of regulatory limitations prior to use.*

2. Referenced Documents

2.1 *ASTM Standards:*²

D543 [Practices for Evaluating the Resistance of Plastics to Chemical Reagents](#)

D883 [Terminology Relating to Plastics](#)

G8 [Test Methods for Cathodic Disbonding of Pipeline Coatings](#)

G12 [Test Method for Nondestructive Measurement of Film Thickness of Pipeline Coatings on Steel](#)

G17 [Test Method for Penetration Resistance of Pipeline Coatings \(Blunt Rod\)](#)

3. Summary of Test Method

3.1 This test method consists of an immersion-type test in a closed container where coated pipe specimens are in long-term contact with both the liquid and vapor phase of the test reagent. Specimens exposed in this manner are inspected for visible signs of chemical attack. Subsequent tests for cathodic disbonding in accordance with Test Method G8, or penetration under load in accordance with Test Method G17, may be applied to determine if the specimens have undergone any loss of mechanical or bonding properties.

4. Significance and Use

4.1 The data obtained for short-term tests are of interest only in eliminating the most unsuitable materials or for indicating a probable order of resistance in any particular media.

4.2 Test conditions should take into account the manner and duration of immersion, the reagent, the temperature of the system, the area exposed above and below the liquid level, and other performance factors selected for the particular test.

5. Apparatus

5.1 *Thickness Gage*, capable of measuring the coating thickness in the manner prescribed by Test Method G12.

5.2 *Test Container*—A transparent closed container, sized to completely encase the pipe specimen and large enough to provide adequate exposure to both the liquid and vapor states of reagent.

NOTE 1—For example, a 2-L (2.0-qt) capacity, Mason-type jar with a 70-mm (2.75-in.) diameter neck has been found suitable for use with 2 in. pipe and is illustrated in Fig. 1.

¹ This test method is under the jurisdiction of ASTM Committee D01 on Paint and Related Coatings, Materials, and Applications and is the direct responsibility of Subcommittee D01.48 on Durability of Pipeline Coating and Linings.

Current edition approved Dec. 10, 2002. Published December 2002. Originally approved in 1971. Last previous edition approved in 1996 as G20-88(1996)^{ε1}. DOI: 10.1520/G0020-88R02.

Current edition approved Dec. 1, 2010. Published December 2010. Originally approved in 1971. Last previous edition approved in 2002 as G20-88(2002). DOI: 10.1520/G0020-10.

² For referenced ASTM standards, visit the ASTM website, www.astm.org, or contact ASTM Customer Service at service@astm.org. For *Annual Book of ASTM Standards* volume information, refer to the standard's Document Summary page on the ASTM website.

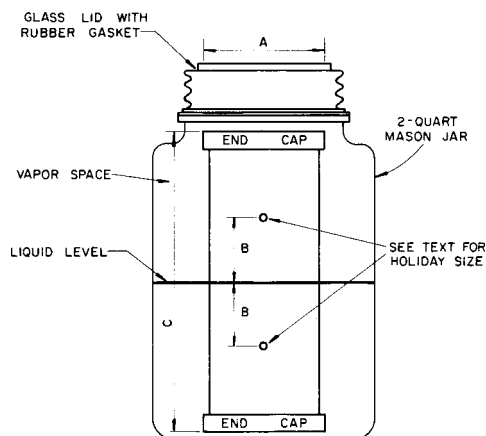

Dimensions
 A—70 mm (2.75 in.) Jar Opening
 B—45 mm (1.75 in.) Holiday Location
 C—90 mm (7.00 in.) Length of Pipe Specimen

NOTE 1—Dimensions shown for 2 in. IPS pipe.

FIG. 1 Chemical Immersion Test Schematic of Test Cell

5.2.1 To avoid pressure build-up within the test containers, the threaded cup shall be replaced with a solid-rubber stopper. A positive venting device, such as a water seal, shall be used when testing with volatile solvents at elevated temperatures.

5.2.2 A separate container shall be used for each test specimen.

5.3 *Oven or Constant-Temperature Room or Bath*—To ensure uniformity of test results, the test cells and specimen shall be maintained at the test temperature $\pm 5^{\circ}\text{C}$ (9°F) over the duration of the test period.

5.4 *Auxiliary Testing Devices*—Supplemental equipment used to determine specific mechanical properties of specimens before and after immersion shall conform to the requirements prescribed in the applicable ASTM test method.

6. Reagents

6.1 The reagents selected for coating-resistance tests should be those anticipated to occur in the environment or in the product being carried in the pipeline at the temperatures and in the concentrations expected. The numbers in parentheses refer to the list of standard reagents given in Section 4 of Practices D543.

- 6.1.1 *Acetic Acid* (5 %) (4.4.2).
- 6.1.2 *Acetone* (4.4.3).
- 6.1.3 *Carbon Disulfide*.
- 6.1.4 *Gasoline*.
- 6.1.5 *Hydrochloric Acid* (10 %) (4.4.23).
- 6.1.6 *Kerosine* (4.4.28).
- 6.1.7 *Lime Water, Saturated*.
- 6.1.8 *Methyl Alcohol* (4.4.29).
- 6.1.9 *Methyl Ethyl Ketone*.
- 6.1.10 *Nitric Acid* (10 %) (4.4.33).
- 6.1.11 *Sodium Carbonate Solution* (20 %) (4.4.38).
- 6.1.12 *Sodium Chloride Solution* (10 %) (4.4.40).
- 6.1.13 *Sodium Hydroxide Solution* (10 %) (4.4.42).
- 6.1.14 *Sulfuric Acid* (30 %) (4.4.46).
- 6.1.15 *Toluene* (4.4.48).
- 6.1.16 *Transformer Oil* (4.4.49).
- 6.1.17 *Trichlorethylene*.
- 6.1.18 Other selected environments.

7. Hazards

7.1 Take safety precautions to avoid personal contact, to eliminate toxic vapors, and to guard against explosion hazards in accordance with the hazardous nature of the particular reagents being used.

8. Test Specimen

8.1 The test specimen shall be prepared with its surface preparation and coating procedures equivalent to that of coated pipe.