



Designation: E1250 – 10

Standard Test Method for Application of Ionization Chambers to Assess the Low Energy Gamma Component of Cobalt-60 Irradiators Used in Radiation-Hardness Testing of Silicon Electronic Devices¹

This standard is issued under the fixed designation E1250; the number immediately following the designation indicates the year of original adoption or, in the case of revision, the year of last revision. A number in parentheses indicates the year of last reapproval. A superscript epsilon (ϵ) indicates an editorial change since the last revision or reapproval.

1. Scope

1.1 Low energy components in the photon energy spectrum of Co-60 irradiators lead to absorbed dose enhancement effects in the radiation-hardness testing of silicon electronic devices. These low energy components may lead to errors in determining the absorbed dose in a specific device under test. This method covers procedures for the use of a specialized ionization chamber to determine a figure of merit for the relative importance of such effects. It also gives the design and instructions for assembling this chamber.

1.2 This method is applicable to measurements in Co-60 radiation fields where the range of exposure rates is 7×10^{-6} to 3×10^{-2} C kg⁻¹ s⁻¹ (approximately 100 R/h to 100 R/s). For guidance in applying this method to radiation fields where the exposure rate is >100 R/s, see [Appendix X1](#).

NOTE 1—See Terminology [E170](#) for definition of exposure and its units.

1.3 The values stated in SI units are to be regarded as the standard. The values given in parentheses are for information only.

1.4 *This standard does not purport to address all of the safety concerns, if any, associated with its use. It is the responsibility of the user of this standard to establish appropriate safety and health practices and determine the applicability of regulatory limitations prior to use.*

2. Referenced Documents

2.1 *ASTM Standards*:²

- [E170 Terminology Relating to Radiation Measurements and Dosimetry](#)
- [E668 Practice for Application of Thermoluminescence-](#)

¹ This method is under the jurisdiction of ASTM Committee [E10](#) on Nuclear Technology and Applications and is the direct responsibility of Subcommittee [E10.07](#) on Radiation Dosimetry for Radiation Effects on Materials and Devices.

Current edition approved Dec. 1, 2010. Published January 2011. Originally approved in 1988. Last previous approved in 2005 as E1250-88(2005). DOI: 10.1520/E1250-10.

² For referenced ASTM standards, visit the ASTM website, www.astm.org, or contact ASTM Customer Service at service@astm.org. For *Annual Book of ASTM Standards* volume information, refer to the standard's Document Summary page on the ASTM website.

[Dosimetry \(TLD\) Systems for Determining Absorbed Dose in Radiation-Hardness Testing of Electronic Devices](#)
[E1249 Practice for Minimizing Dosimetry Errors in Radiation Hardness Testing of Silicon Electronic Devices Using Co-60 Sources](#)

3. Terminology

3.1 *absorbed dose, D*—quotient of $d\bar{\epsilon}$ by dm , where $d\bar{\epsilon}$ is the mean energy imparted by ionizing radiation to the matter in a volume element and dm is the mass of matter in that volume element.

$$D = d\bar{\epsilon}/dm \quad (1)$$

3.2 *absorbed dose enhancement factor*—ratio of the absorbed dose at a point in a material of interest to the equilibrium absorbed dose in that same material.

3.3 *average absorbed dose*—mass-weighted mean of the absorbed dose over a region of interest.

3.4 *average absorbed dose enhancement factor*—ratio of the average absorbed dose in a region of interest to the equilibrium absorbed dose.

3.5 *dosimeter*—any device used to determine the equilibrium absorbed dose in the material and at the irradiation position of interest. Examples of such devices include thermoluminescence dosimeters (TLDs), liquid chemical dosimeters, and radiochromic dye films. (See Practice [E668](#), for a discussion of TLDs.)

3.6 *equilibrium absorbed dose*—absorbed dose at some incremental volume within the material in which the condition of charged particle equilibrium (the energies, number, and direction of charged particles induced by the radiation are constant throughout the volume) exists. (See Terminology [E170](#).)

4. Significance and Use

4.1 Although Co-60 nuclei only emit monoenergetic gamma rays at 1.17 and 1.33 MeV, the finite thickness of sources, and encapsulation materials and other surrounding structures that are inevitably present in irradiators can contribute a substantial

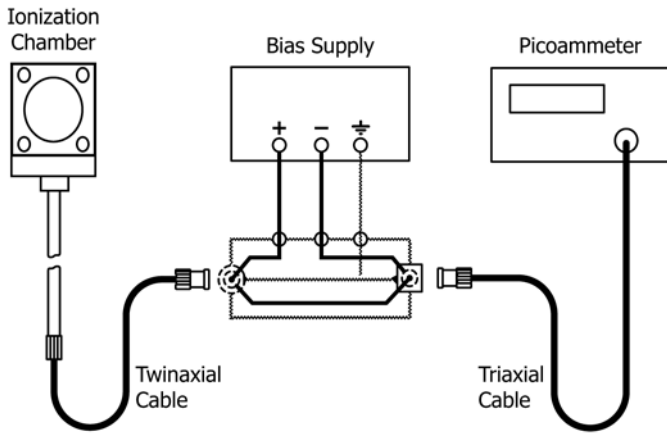

FIG. 1 Schematic Diagram of Experimental Setup

physical dimensions (all dimensions given in inches):

| | |
|--------------------------------------|-------|
| Nominal outer diameter | 0.242 |
| Conductor spacing (center to center) | 0.076 |
| Conductor dielectric outer diameter | 0.076 |
| Conductor diameter | 0.037 |

Other equivalent twinaxial cable types can be used, but the applicable dimensions of the ionization chamber body, clamp, stem, and cable clamp nut in Appendix X2 must then be adjusted.

5.5 *Triaxial Cable*, the triaxial cable that connects the ionization chamber and the bias supply to the electrometer is usually supplied with the electrometer, and must be of a type that is compatible with the electrometer type used (see Fig. 1).

6. Procedure

6.1 Assemble the ionization chamber, bias supply, and electrometer as shown in Fig. 1.

6.2 Turn on the bias supply, set the voltage to at least 60 V, and ensure that there is no appreciable leakage current ($I_{leakage} < 0.1$ pA). Turn the bias supply off.

6.3 Assemble the ionization chamber with the gold/aluminum electrodes (the gold sides facing the inside of the chamber). Place the ionization chamber in the irradiation position of interest. For directional sources, position the ionization chamber so that the direction of the main beam is perpendicular to the electrode plates.

6.4 Turn on the bias supply and measure the ionization current, I_{Au} , with the gold/aluminum electrodes in place, gold side facing inward.

6.5 Repeat steps 6.3 and 6.4 with aluminum electrodes and measure the ionization current I_{Al} . The ionization chamber location and orientation shall be the same for both measurements.

6.6 Calculate the ionization current ratio α as follows:

$$\alpha = I_{Au}/I_{Al} \quad (2)$$

This ratio provides a figure of merit for the particular Co-60 irradiator configuration under investigation.

NOTE 3—Since the relationship between ionization chamber current and exposure rate depends on such environmental factors as temperature, atmospheric pressure, and relative humidity, it is important to make the two measurements of I_{Au} and I_{Al} as nearly at the same time as possible to minimize the influence of environmental factors on the ratio I_{Au}/I_{Al} .

7. Interpretation of Measurement Results

7.1 Low values of the figure of merit, α (≈ 2 to 2.5) are indicative of a relatively small low-energy photon component, and high values of α (> 5) indicate a very large low-energy photon component. Appendix X3 gives a table of measured values of α for a variety of typical Co-60 irradiator facilities and experimental arrangements.

NOTE 4—Monoenergetic 1.25 MeV photon radiation would theoretically produce a value of $\alpha = 1.6$. Although this value is not attainable with any realistic Co-60 irradiator configuration, it is a theoretical lower limit on α .

7.2 If the measured value of α is > 2.5 , steps 6.1 – 6.5 should be repeated with the ionization chamber surrounded by a filter can or box of 1.5 to 2.0 mm (approximately 0.063 in.) of lead

amount of low-energy gamma radiation, principally by Compton scattering (1, 2).³ In radiation-hardness testing of electronic devices this low-energy photon component of the gamma spectrum can introduce significant dosimetry errors for a device under test since the equilibrium absorbed dose as measured by a dosimeter can be quite different from the absorbed dose deposited in the device under test because of absorbed dose enhancement effects (3, 4). Absorbed dose enhancement effects refer to the deviations from equilibrium absorbed dose caused by non-equilibrium electron transport near boundaries between dissimilar materials.

4.2 The ionization chamber technique described in this method provides an easy means for estimating the importance of the low-energy photon component of any given irradiator type and configuration.

4.3 When there is an appreciable low-energy spectral component present in a particular irradiator configuration, special experimental techniques should be used to ensure that dosimetry measurements adequately represent the absorbed dose in the device under test. (See Practice E1249.)

5. Apparatus

5.1 *Ionization Chamber*, a specially fabricated parallel-plate ionization chamber with interchangeable gold and aluminum electrodes. A specific design is described in Appendix X2.

5.2 *Bias Supply*, a battery or power supply capable of delivering 60 to 100 V dc at a current up to 1 mA.

5.3 *Electrometer*, an electrometer or picoammeter capable of measuring currents as low as 30 pA with a resolution of at least 0.1 pA.

5.4 *Twinaxial Cable*, the twinaxial cable that connects the ionization chamber to the bias supply and electrometer is an integral part of the ionization chamber (see Fig. 1).

NOTE 2—The ionization chamber dimensions given in Appendix X2 are appropriate to TWC 78-2 twinaxial cable.⁴ This cable has the following

³ The boldface numbers in parentheses refer to the list of references appended to this test method.

⁴ Available from Trompeter Electronics, 31186 La Baya Dr., Westlake Village, CA 91362-4047.

on the outside and 0.7 to 1.0 mm (approximately 0.030 in.) of aluminum on the inside. Use of such a filter will normally give a significant reduction in the low-energy component of the spectrum (see Practice E1249).

7.3 By repeating the procedure for a number of source configurations and filter options, the experimental conditions can be determined that minimize the low-energy photon component of the source spectrum and thus minimize the dosimetry errors for the device under test.

8. Application to Hardness Testing

8.1 Estimating the Absorbed Dose Enhancement Factor:

8.1.1 Although it is not possible to determine the absorbed dose enhancement factor for a particular geometry of a device under test using this method, the figure of merit, α , can be used to estimate an upper bound for the absorbed dose enhancement factor near an interface between any two materials (5).

8.1.2 A specific example of relating the figure of merit, α , to the absorbed dose enhancement is given in 8.1.4 for the case of a silicon-gold interface. This example is of particular interest in radiation-hardness testing of silicon electronic devices because it does exist for many devices, and is a worst-case configuration.

NOTE 5—Silicon-gold interfaces in electronic devices typically consist of relatively thin layers; however, the case considered here is an interface between two layers each having a thickness capable of producing absorbed dose equilibrium. This case has been used because it represents a configuration that is relatively easy to calculate. Further, it gives a worst case estimate of the absorbed dose enhancement factor for a silicon-gold interface.

8.1.3 The absorbed dose enhancement factor at the interface is defined by the following:

$$F_{DE}(Si: Au) = D_{Si}(IF)/D_{Si}(eq) \tag{3}$$

where:

- $D_{Si}(IF)$ = absorbed dose in silicon immediately adjacent to the silicon-gold interface, and
- $D_{Si}(eq)$ = equilibrium absorbed dose in silicon.

8.1.4 The relationship between the ionization current ratio, α , and an estimate of $F_{DE}(Si: Au)$ is shown in Fig. 2. The basis for this relationship is discussed briefly in Appendix X4.

NOTE 6—Based on the assumptions inherent in Fig. 2 and Appendix X4, monoenergetic 1.25 MeV photon radiation will produce a value of $F_{DE}(Si: Au) = 1.64$. Such a low value is not attainable in any practical Co-60 irradiator configuration.

8.1.5 An estimated absorbed dose enhancement factor at a gold-silicon interface irradiated by a practical Co-60 source may be obtained by using Fig. 2. For example, a measured ionization current ratio of 2.5 would be considered a good figure of merit for a given irradiator configuration. In this case, Fig. 2 gives an estimate of the absorbed dose enhancement factor of about 1.8 as compared to an estimated absorbed dose enhancement factor of 1.64 for monoenergetic 1.25 MeV gamma radiation; therefore, the dosimetry error for a device under test incurred by neglecting the low energy photon component would be about 10%. On the other hand, a measured ionization current ratio of 7.5 would be considered a poor figure of merit for another irradiator configuration. In this

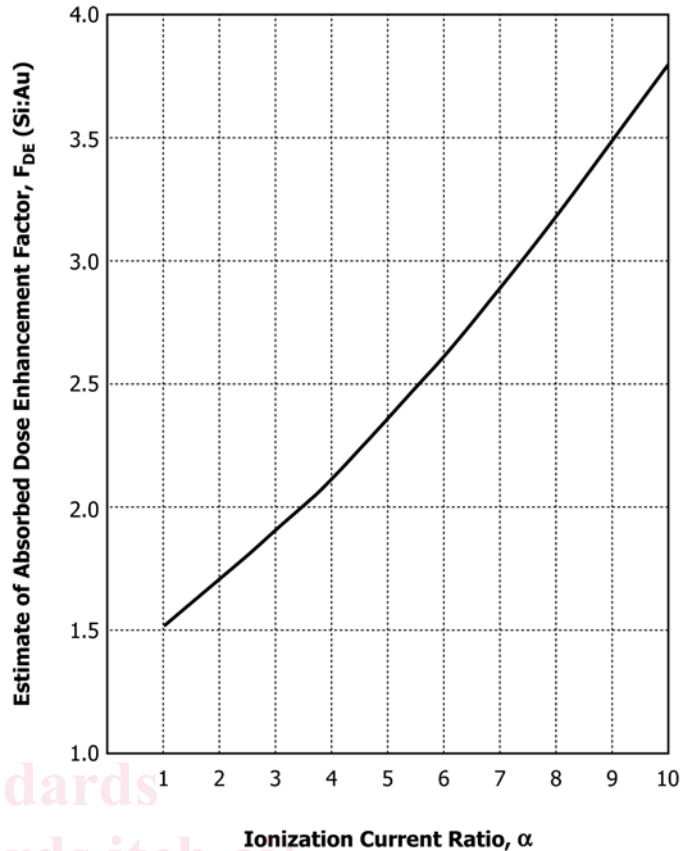

FIG. 2 Relationship for Estimating Absorbed Dose Enhancement Factor in Silicon at a Silicon-Gold Interface From the Ionization Current Ratio

case, the corresponding estimated absorbed dose enhancement factor would be about 3.0; therefore, neglecting the low energy spectral component would lead to a dosimetry error for a device under test of as much as a factor of 1.8. For such a configuration, the use of a lead-aluminum filter box would minimize the dosimetry error, and, therefore should be considered (see Practice E1249).

8.2 Selecting a Lead-Aluminum Filter for Spectrum Hardening:

8.2.1 Except for very soft spectra, the use of a filter box of 1.5 to 2.0 mm (≈ 0.063 in.) of lead on the source side, followed by 0.7 to 1.0 mm (≈ 0.030 in.) of aluminum on the test object side, (see Practice E1249), will harden the spectrum sufficiently to reduce α to ≤ 2.5 (see Table X3.1). This value of α corresponds to a dosimetry error of less than 10%.

8.2.2 A greater wall thickness of lead for the filter box than specified in 8.2.1 should be considered for a source configuration having a large fraction of low-energy photon components; that is, for $\alpha > 6$. For example, a wall thickness of 3.2 mm (≈ 0.125 in.) of lead may be useful for the cases of the last three entries in Table X3.1.

9. Precision and Bias

9.1 The lowest ionization chamber current to which this method is applicable is 30 pA (corresponding to 7×10^{-6} C $kg^{-1} s^{-1}$ [approximately 100 R/h]), which can be measured

with a precision of 0.5 pA or $\pm 1.7\%$, as specified by the instrument manufacturer. The ratio I_{Au}/I_{Al} can therefore be determined to an overall uncertainty of $\pm 2.4\%$ or better.

9.2 This method provides a figure of merit usable for comparing various source configurations, and for assessing the relative improvement that is achievable with a lead-aluminum filter. This method gives no quantitative information about absorbed dose enhancement factor other than an estimate of its upper limit.

10. Keywords

10.1 absorbed dose; Co-60 irradiators; dose enhancement; ionization chamber; radiation hardness testing

APPENDIXES

(Nonmandatory Information)

X1. APPLICATION OF THIS METHOD TO HIGH EXPOSURE RATES

X1.1 The limits of applicability of this method given in 1.2 are for exposure rates less than $3 \times 10^{-2} \text{ C kg}^{-1} \text{ s}^{-1}$ (<100 R/s). It may be possible to apply this method to exposure rates higher than 100 R/s if the following guidelines are applied.

X1.2 The collection efficiency, f , of an ionization chamber is defined as the ratio of the ions collected at the electrodes to the total number of ions generated in the active volume. Ideally, the collection efficiency of an ionization chamber should be ≈ 1.0 . This method deals with current ratios and not with absolute measurement of ionization current versus exposure rate. However, in order to achieve the precision of this method, a collection efficiency of ≥ 0.95 is recommended.

X1.3 *Relationship Between Collection Efficiency and Minimum Bias Voltage:*

X1.3.1 The collection efficiency of a parallel plate ionization chamber is given by the following (6):

$$f = 1 / (1 + m^2 \dot{X} d^4 / 6V^2) \quad (\text{X1.1})$$

where:

m = Boag's constant for air = $36.7 \text{ V s}^{1/2} \text{ cm}^{-1/2} \text{ esu}^{-1/2}$,
 \dot{X} = exposure rate, R/s (1 R/s = $\text{esu cm}^{-3} \text{ s}^{-1}$),

d = electrode spacing, cm (0.3 cm for this method), and
 V = bias voltage, volts.

X1.3.2 Solving Eq X1.1 for V results in the following:

$$V = d^2 \times [f m^2 \dot{X} / 6(1 - f)]^{1/2} \quad (\text{X1.2})$$

Use the following set of variables as follows:

$d = 0.3 \text{ cm}$,
 $f \geq 0.95$,
 $m = 36.7$, and
 $\dot{X} = 100 \text{ R/s}$.

The result is $V \geq 60 \text{ V}$.

X1.4 This method may be applied at exposure rates higher than 100 R/s if the bias voltage, V , is increased to values greater than 60 V according to Eq X1.2. However, the collection efficiency should be verified experimentally in each case by measuring the ionization current versus bias voltage up to the highest exposure rate anticipated. Then the method should yield valid results if no significant increase in measured ionization current occurs for a bias voltage greater than the one chosen.

X2. COMPLETE FABRICATION DRAWINGS FOR THE GOLD- AND ALUMINUM-WALLED IONIZATION CHAMBER

X2.1 This design is for a parallel plate ionization chamber with an active volume of 40-mm diameter and 3-mm thickness. The sensitivity of this ionization chamber with aluminum plates is approximately $4 \times 10^{-6} \text{ A/[C kg}^{-1} \text{ s}^{-1}]$ ($\approx 1.25 \text{ nA/[r s}^{-1}]$) (5).

X2.2 An exploded view of the complete ionization chamber is shown in Fig. X2.1. Details for the fabrication and assembly of the individual parts of the ionization chamber are given in Figs. X2.2-X2.8.

NOTE X2.1—All dimensions on Figs. X2.3-X2.8 are given in inches. 1 in. = 25.4 mm.

X2.3 *Assembly of the Ionization Chamber:*

X2.3.1 Strip the twinaxial cable to the dimensions shown in Fig. X2.2(a). (These dimensions are appropriate to Trompeter cable TWC 78-2, see Note 2 for the use of other cable types). Very light tinning of the stranded conductors is helpful to prevent fraying of the conductor ends.

X2.3.2 Insert the prepared cable into the stem (Fig. X2.7) so that approximately 2 mm of the braid protrudes from the knurled end of the stem (see Fig. X2.2(b)).

X2.3.3 Insert the cable and stem assembly into the ionization chamber body (Fig. X2.3) so that one conductor fits into each of the two #60 holes. Make sure that the conductor extends to the bottom of the hole.

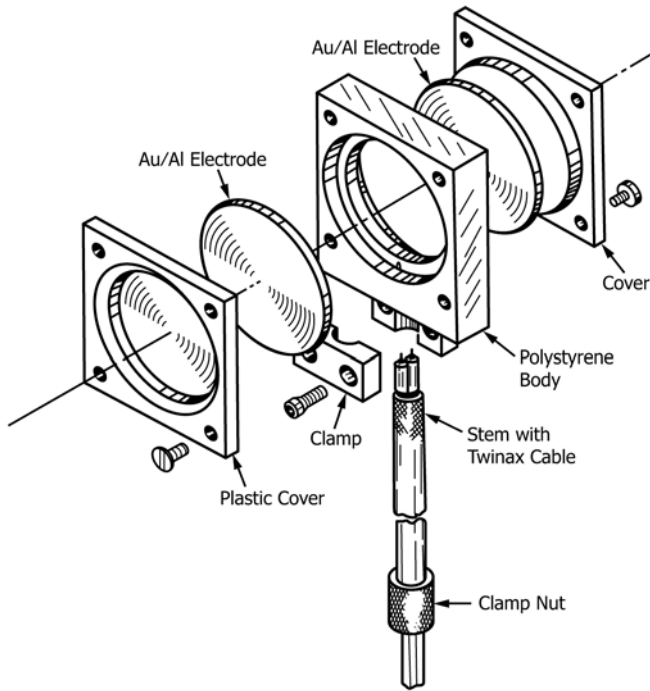
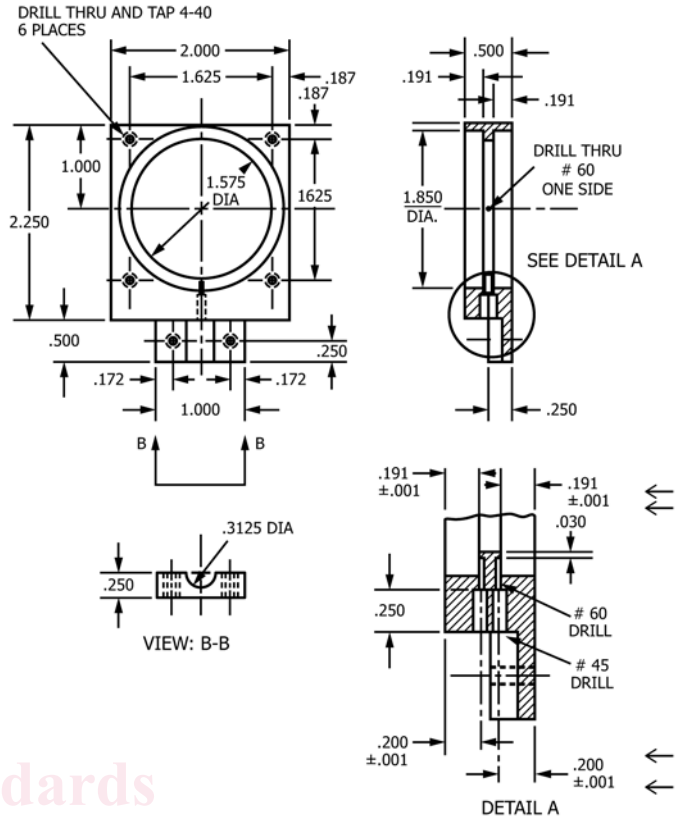

FIG. X2.1 Ionization Chamber (Exploded View)



Material: Polystyrene.
Quantity Required: 1.

NOTE 1—1 in. = 25.4 mm.

FIG. X2.3 Ionization Chamber Body

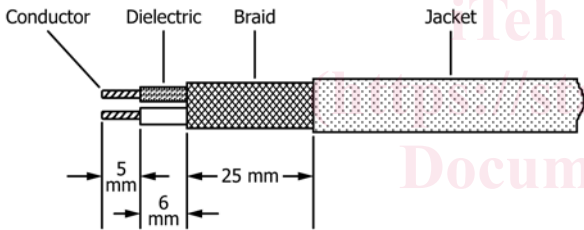

(a) Twinax Cable Preparation

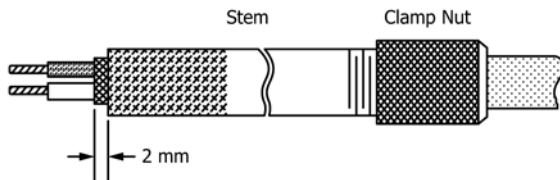

(b) Assembly of Twinax Cable to Stem

FIG. X2.2 Ionization Chamber Assembly Details

X2.3.4 Secure the stem (Fig. X2.7) to the ionization chamber body (Fig. X2.3) with the clamp (Fig. X2.4).

X2.3.5 Tighten the cable clamp nut (Fig. X2.8) to the stem (Fig. X2.7) so that the twinax cable is securely clamped to the stem.

X2.3.6 Cement the two 0.05 mm (0.002 in.) thick gold foil discs into the recesses in each side of the ionization chamber body (Fig. X2.3) and secure them with the ionization chamber covers (Fig. X2.5) by means of four screws as shown in Fig. X2.1. Electrical contact from the cable to the electrodes is accomplished by the covers pressing the electrodes against the exposed conductor ends of the twinax cable.

X2.3.7 Place the two electrodes (Fig. X2.6) into the recesses in each side of the ionization chamber body (Fig. X2.3) and secure them with the ionization chamber covers (Fig. X2.5) by means of four screws as shown in Fig. X2.1. Electrical contact from the cable to the electrodes is accomplished by the covers pressing the electrodes against the exposed conductor ends of the twinax cable.

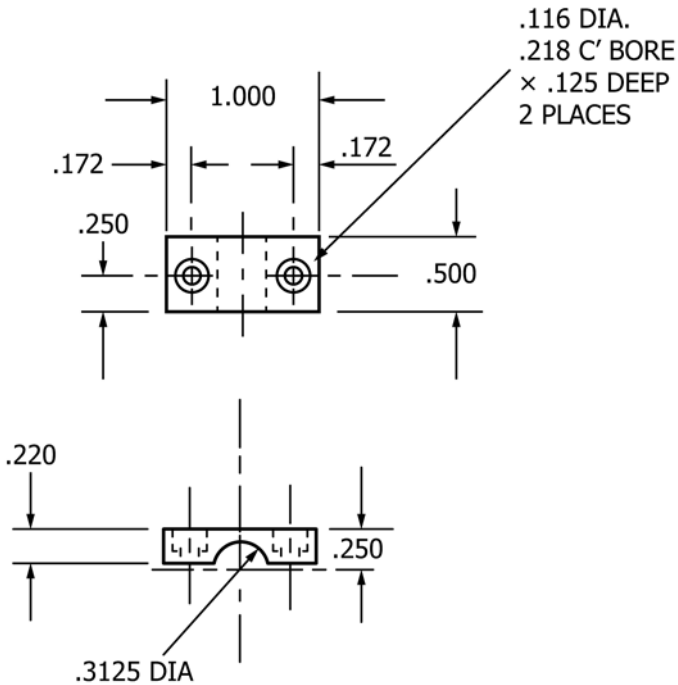

Material: Aluminum.
Quantity Required: 1.

NOTE 1—1 in. = 25.4 mm.

FIG. X2.4 Ionization Chamber Clamp

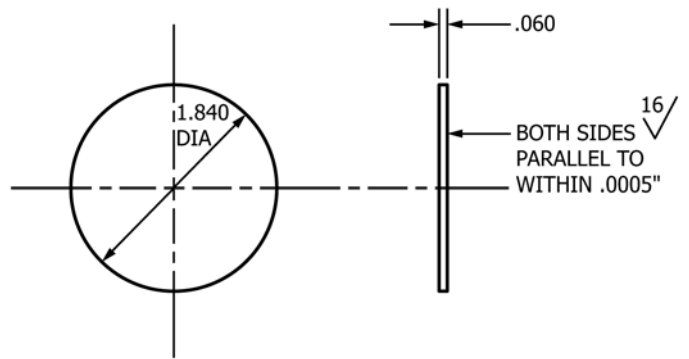

Material: Aluminum Alloy 7075.
Quantity Required: 4.

NOTE 1—

2 pieces plain.

2 pieces with 0.002 in. gold foil bonded to one side cyanoacrylate ester.

use adhesive.

NOTE 2—1 in. = 25.4 mm.

FIG. X2.6 Ionization Chamber Electrode

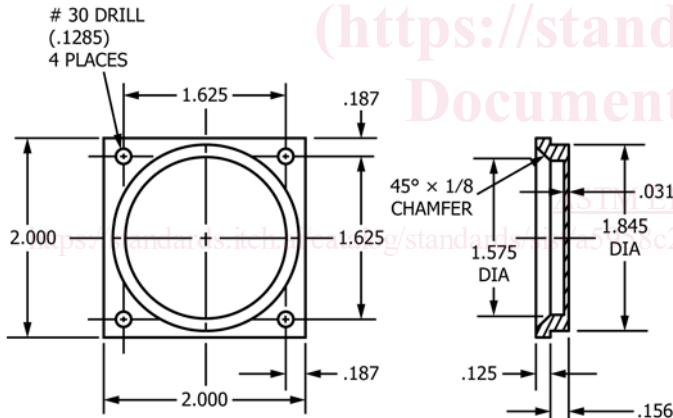

Material: Polycarbonate plastic.
Quantity Required: 2.

NOTE 1—1 in. = 25.4 mm.

FIG. X2.5 Ionization Chamber Cover

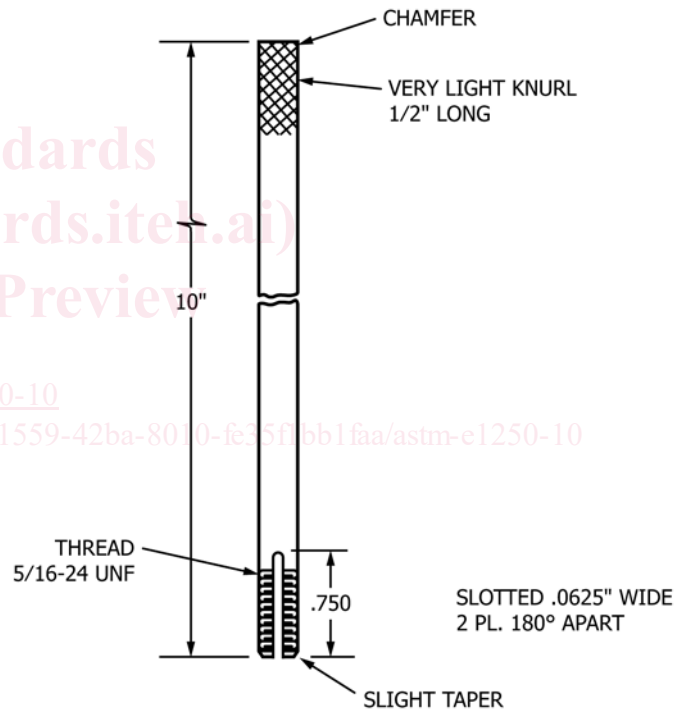

Quantity Required: 1.

Make from: 0.312 O.D. × 0.257 I.D. aluminum tubing.

NOTE 1—1 in. = 25.4 mm.

FIG. X2.7 Ionization Chamber Stem