



Designation: D4340 – 10

# Standard Test Method for Corrosion of Cast Aluminum Alloys in Engine Coolants Under Heat-Rejecting Conditions<sup>1</sup>

This standard is issued under the fixed designation D4340; the number immediately following the designation indicates the year of original adoption or, in the case of revision, the year of last revision. A number in parentheses indicates the year of last reapproval. A superscript epsilon ( $\epsilon$ ) indicates an editorial change since the last revision or reapproval.

## 1. Scope

1.1 This test method covers a laboratory screening procedure for evaluating the effectiveness of engine coolants in combating corrosion of aluminum casting alloys under heat-transfer conditions that may be present in aluminum cylinder head engines.

1.2 *This standard does not purport to address all of the safety concerns, if any, associated with its use. It is the responsibility of the user of this standard to establish appropriate safety and health practices and determine the applicability of regulatory limitations prior to use.* Specific precautionary statements are given in Sections 11 and 12.

## 2. Referenced Documents

2.1 *ASTM Standards:*<sup>2</sup>

D1176 Practice for Sampling and Preparing Aqueous Solutions of Engine Coolants or Antirusts for Testing Purposes

## 3. Summary of Test Method

3.1 In this test method, a heat flux is established through a cast aluminum alloy typical of that used for engine cylinder heads while exposed to an engine coolant under a pressure of 193 kPa (28 psi). The temperature of the aluminum specimen is maintained at 135°C (275°F) and the test is continued for 1 week (168 h). The effectiveness of the coolant for preventing corrosion of the aluminum under heat-transfer conditions (hereafter referred to as heat-transfer corrosion) is evaluated on the basis of the weight change of the test specimen.

## 4. Significance and Use

4.1 It is essential that engine coolants prevent heat-transfer corrosion of aluminum cylinder heads during engine operation. Any corrosion products formed may deposit on interior radia-

tor surfaces, reducing heat-transfer efficiency of the radiator. Overheating and boil-over of the cooling system may then occur.

4.2 This test method provides a means for selectively screening unused engine coolants and will readily distinguish those coolants that are unsuitable for use with aluminum cylinder head engines. However, satisfactory performance of a coolant in this test method does not ensure adequate long-term service performance. Additional, more comprehensive evaluations with simulated service, dynamometer, and vehicle tests should be used to establish the long-term effectiveness of the coolant.

## 5. Apparatus

5.1 *Heat-Transfer Corrosion Cell*—The assembled corrosion cell is shown schematically in Fig. 1. It is assembled from components, some of which require glass blowing or machining. The glass O-ring cell shall be constructed from two glass O-ring joints<sup>3</sup> joined to an additional middle section of glass tubing<sup>4</sup> of the same diameter to make a total length of 53 cm (21 in.). Heat-resistant O-rings<sup>5</sup> shall be used. Internal pressure shall be monitored using a suitable pressure gage,<sup>6</sup> and a pressure-relief valve<sup>7</sup> shall be installed to protect against bursting.

5.1.1 The top assembly plate (shown in Fig. 2) shall be constructed of stainless steel, and the heat-transfer bar and bottom assembly plate (also illustrated in Fig. 2) shall preferably be constructed of stainless steel. Mild steel may be used for the heat-transfer bar and bottom assembly plate.

<sup>3</sup> Corning 6780, No. 40 Pyrex Brand O-ring joints have been found satisfactory. Equivalent O-ring joints with a low coefficient of expansion may be used.

<sup>4</sup> Pyrex Brand Glass, a trademark of Corning Glass Works, with a standard wall thickness of 2.0 mm has been found satisfactory. Equivalent high-strength glass with a low coefficient of expansion may be used.

<sup>5</sup> Viton, a trademark of E.I. duPont de Nemours and Co., Inc. has been found satisfactory. Silicone O-rings may also be satisfactory. Polytetrafluoroethylene is not suitable due to a high creep rate at the test temperature.

<sup>6</sup> Ametek, U.S. Gauge Division, Model E-82 has been found satisfactory. An equivalent pressure gage may be used.

<sup>7</sup> Nupro, Catalog No. SS-4CPA2-3 has been found satisfactory. An equivalent pressure relief valve may be used.

<sup>1</sup> This test method is under the jurisdiction of ASTM Committee D15 on Engine Coolants and is the direct responsibility of Subcommittee D15.06 on Glassware Performance Tests.

Current edition approved Dec. 1, 2010. Published January 2011. Last previous edition approved in 2007 as D4340 – 96(2007). DOI: 10.1520/D4340-10.

<sup>2</sup> For referenced ASTM standards, visit the ASTM website, www.astm.org, or contact ASTM Customer Service at service@astm.org. For *Annual Book of ASTM Standards* volume information, refer to the standard's Document Summary page on the ASTM website.

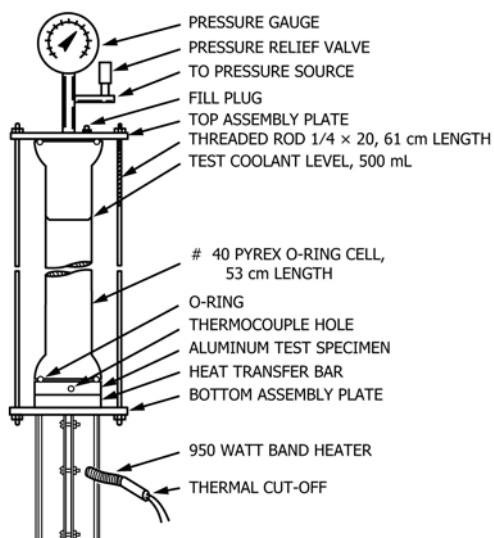
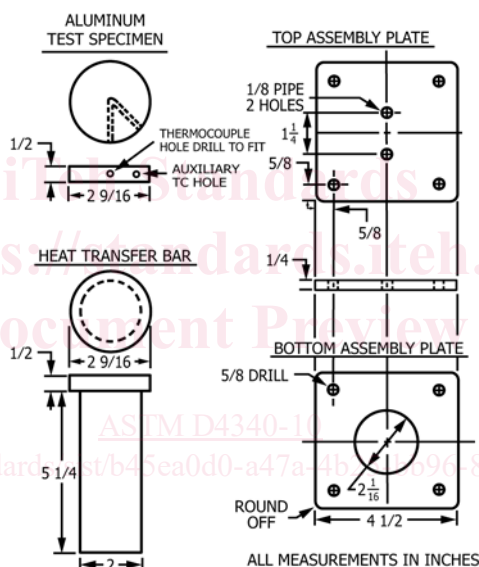

FIG. 1 Heat-Transfer Corrosion Test Assembly



Metric Equivalents

in.	1/4	1/2	5/8	1 1/4	2	2 1/16	2 9/16	4 1/2	5 1/4
mm	6.35	12.7	15.88	31.75	50.8	52.39	65.09	114.3	133.35

FIG. 2 Heat-Transfer Corrosion Test Components

5.2 *Temperature Controller*,<sup>8</sup> with high-temperature alarm option and temperature control range up to at least 150°C (302°F). Use Type J thermocouple. A heavy-duty electrical power relay or SCR solid-state contactor is connected to the temperature controller to carry the current load to the band heaters.

5.3 *Electrical Relay*,<sup>9</sup> 30-amp rating. The relay is changed after about every 50 000 cycles to prevent contact welding.

<sup>8</sup> Athena, Model 2500T-B-16 F/C used with an electrical power relay or Model 2500S-B-16 F/C used with an SCR solid-state contractor has been found satisfactory. An equivalent temperature controller may be used.

<sup>9</sup> Dayton 5X850A, SPST-NO-DM, 120 V, 30 amp has been found satisfactory. An equivalent mechanical or solid-state relay may be used.

5.4 *Band Heaters*,<sup>10</sup> at least 950 W, 120-V ac, 5.1-cm (2-in.) inside diameter, 12.7-cm (5-in.) length.

5.5 *Ultrasonic Cleaner*,<sup>11</sup> about 50 W, for cleaning aluminum test samples.

5.6 *Vacuum Oven*,<sup>12</sup> with temperature range up to about 150°C (302°F) for thoroughly drying cast aluminum samples.

<sup>10</sup> Hotwatt, 950-W standard construction band heater, standard tightening clamp, Type L terminal has been found satisfactory. An equivalent band heater may be used.

<sup>11</sup> Branson Model 12, 50 W, 1-qt capacity has been found satisfactory. An equivalent ultrasonic cleaner may be used.

<sup>12</sup> Thelco Model 10 has been found satisfactory. An equivalent vacuum oven may be used.