



Designation: D1995 – 92 (Reapproved 2011)

Standard Test Methods for Multi-Modal Strength Testing of Autohesives (Contact Adhesives)¹

This standard is issued under the fixed designation D1995; the number immediately following the designation indicates the year of original adoption or, in the case of revision, the year of last revision. A number in parentheses indicates the year of last reapproval. A superscript epsilon (ϵ) indicates an editorial change since the last revision or reapproval.

1. Scope

1.1 These test methods cover procedures by which autohesives can be tested in four commonly practiced stressing modes, namely: compression shear, cleavage, climbing drum peel, and T-peel, and in various combinations of rigid-to-rigid, flexible-to-rigid, and flexible-to-flexible adherends that include wood, aluminum, steel flakeboard, and plastic laminates. Quantitative test methods that involve bond formation by impact are also provided. Three pressure modes are provided: static, roller, and impact. Because there are many types of contact adhesives being used to bond many different materials under widely differing conditions, these test methods are designed to allow the user to select the test mode, coating thickness, temperature and relative humidity conditions, pressure magnitude and mode, open time, and bond-conditioning time.

1.1.1 The bond-formation process used with autohesives is unlike that of all other adhesives and in consequence, testing of autohesives requires methods that are unlike those provided by other ASTM standards. See [Annex A1](#).

1.2 A choice of adherends is available in each test mode. The combination of adherends that can be bonded together is limited to those shown in [Appendix X1](#).

1.3 Methods for application of pressure are available in each test mode. For a particular combination of substrates, the means available for application of pressure are limited to those shown in [Appendix X2](#).

1.4 The values stated in inch-pound units are to be regarded as standard. The values given in parentheses are mathematical conversions to SI units that are provided for information only and are not considered standard.

1.5 *This standard does not purport to address all of the safety concerns, if any, associated with its use. It is the responsibility of the user of this standard to establish appropriate safety and health practices and determine the applica-*

bility of regulatory limitations prior to use. Specific precautionary statements are given in [7.5](#).

2. Referenced Documents

2.1 ASTM Standards:²

- [D905 Test Method for Strength Properties of Adhesive Bonds in Shear by Compression Loading](#)
- [D907 Terminology of Adhesives](#)
- [D1062 Test Method for Cleavage Strength of Metal-to-Metal Adhesive Bonds](#)
- [D1151 Practice for Effect of Moisture and Temperature on Adhesive Bonds](#)
- [D1781 Test Method for Climbing Drum Peel for Adhesives](#)
- [D1876 Test Method for Peel Resistance of Adhesives \(T-Peel Test\)](#)
- [D2651 Guide for Preparation of Metal Surfaces for Adhesive Bonding](#)
- [E4 Practices for Force Verification of Testing Machines](#)

3. Terminology

3.1 Definitions:

3.1.1 Many terms in these test methods are defined in [Terminology D907](#).

3.1.2 *autohesion, n*—adhesion developed by interdiffusion of the molecules of two solid surfaces of the same material and consequent obliteration of the interface between them.

3.1.3 *autohesive, n*—an adhesive possessing the property of autohesion. (Also called contact-bond adhesive and dry-bond adhesive.)

3.1.4 *shear strength, n*—in adhesive joint, the maximum average stress when a force is applied parallel to the joint.

3.1.4.1 *Discussion*—In most adhesive test methods, the shear strength is actually the maximum average stress at failure of the specimen, not necessarily the true maximum stress in the material.

3.2 Definitions of Terms Specific to This Standard:

¹ These test methods are under the jurisdiction of ASTM Committee D14 on Adhesives and are the direct responsibility of Subcommittee D14.70 on Construction Adhesives.

Current edition approved Jan. 1, 2011. Published January 2011. Originally approved in 1991. Last previous edition approved in 2004 as D1995 – 92 (2004). DOI: 10.1520/D1995-92R11.

² For referenced ASTM standards, visit the ASTM website, www.astm.org, or contact ASTM Customer Service at service@astm.org. For *Annual Book of ASTM Standards* volume information, refer to the standard's Document Summary page on the ASTM website.

3.2.1 *autohesive (contact) failure, n*—a condition in which no contact appears to have occurred between the two layers of autohesive, as evidence by visual inspection of the specimen after destructive testing.

3.2.2 *bond-conditioning time, n*—the time elapsed between making the bonded assembly and testing it or specimens made from it.

4. Summary of Test Methods

4.1 The autohesive is conditioned to the temperature selected for the coating application, the substrates are surfaced flat, precut or cleaned, or both, as required, and then conditioned to the temperature and humidity preselected for the coating application. Under controlled temperature and humidity, a film of autohesive of predetermined wet-film thickness is coated on to the substrates, and allowed to dry for the duration of the open-assembly time. The coated materials are brought together with light finger pressure, and bonded assemblies are made by applying pressure. Pressure may be applied in one of three ways: static, impact, or roller. Assemblies are conditioned in a controlled environment for a specified time, the bond-conditioning time. Assemblies are cut into specimens where required. Assemblies requiring no cutting, or precut specimens, are tested destructively in either of the four modes described in Sections 8, 9, 10, and 11.

5. Significance and Use

5.1 The application procedures in these test methods yield films free of the irregularities, artifacts, and variations inherent in brushing, spraying, or trowelling. Accordingly, these test methods measure the strength of autohesive bonds between two autohesive films whose topography is characteristic of the autohesive itself rather than the artifacts of the application procedure. It is recommended that this information be considered in extrapolating results from these test methods.

5.2 The magnitude of the measured bond strengths also depends on other factors such as film thickness, the manner in which pressure is applied, the magnitude and duration of the application of pressure, and the temperature and humidity at various stages of the test. Accordingly, these parameters should be chosen in a manner consistent with the end use of the autohesive.

5.3 In case of a dispute arising from differences in reported results when using these test methods for acceptance testing of commercial shipments, the purchaser and the supplier should conduct comparative tests to diagnose the causes for lack of repeatability between their laboratories. Competent statistical assistance is recommended for the investigation of precision. As a minimum, the two parties should select a group of test specimens and visually examine their failure modes. The average results from the two laboratories should then be compared using Student's *t*-test for unpaired data and an acceptable probability level should be chosen by the two parties before testing is begun.

6. Apparatus

6.1 Testing Machines:

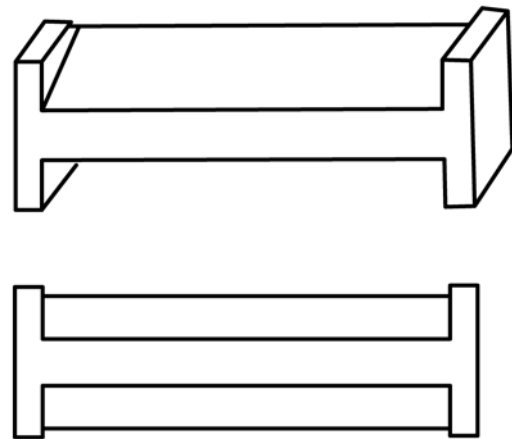

FIG. 1 One Type of Knife Applicator

6.1.1 Test Methods D905, D1062, D1781, D1876, and Guide D2651 independently specify the testing machine relevant to these test methods.

6.1.2 To perform all tests in these test methods, the testing machine must meet the following requirements:

6.1.2.1 Capability of performing tests in tension and compression; load range 4400 lb (2000 N).

6.1.2.2 Rate of movement of the cross-head must be constant and independent of any fluctuation of the load.

6.1.2.3 A range of cross-head speeds from 0.05 in./min (1.27 mm/min) to 2 in./min, (50 mm/min).

6.1.2.4 The machine must be provided with a load-rate controller capable of controlling the load rate from 600 to 700 lbf/min (2700 to 3200 N/min).

6.1.2.5 Autographic equipment to record the load-versus-head movement.

6.1.3 Verification of the testing equipment may be made in accordance with the recommendations of Practices E4.

6.2 *Equipment for Environmental Temperature and Humidity Control*—Equipment must be capable of maintaining relative humidity within $\pm 2\%$ of the selected value, and temperature within $\pm 2^\circ\text{F}$ ($\pm 1^\circ\text{C}$) of the selected value.

6.3 *Applicators*—Fixed or variable-gap applicators, commonly called knife applicators, may be used. The knife design, shown in Fig. 1³ or similar applicators provided with side guide arms at least 1 in. (25 mm) long, are preferred. Applicators shall be wide enough for the guide arms to ride on the rider pieces and at least 1 in. (25 mm), away from the edge of center substrate during application, as in Fig. 2. Wide-wound-rod applicators may also be used for deposition of wet films 0.002 to 0.010 in. (0.051 to 0.254 mm) thick. These applicators obviate the need for restraining devices to maintain flatness of sheet substrates while coating and are generally preferred over knife applicators provided the required wet-film thickness does not exceed 0.01 in. (0.254 mm). The wide-wound portion of the rod should be at least 2 in. (50 mm)

³ Available from Precision Gage and Tool Co., Dayton, Ohio 45410.

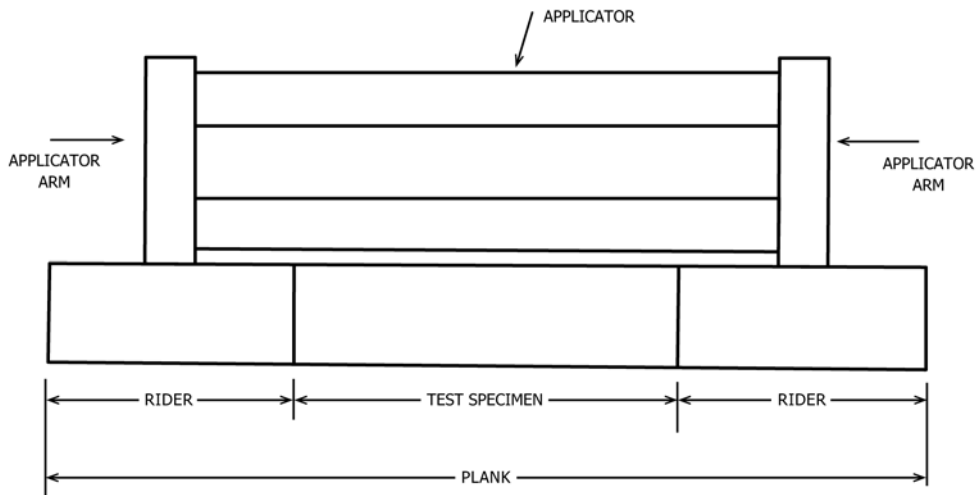

FIG. 2 Applicator Placed on Material for Coating

longer than the adherend width. The wet-film thickness deposited by all wide-wound-rod applicators is not predictable from the diameter of the wire. Consult the manufacturer's data.⁴

6.4 *Float-Glass Plate*, ¼ in. (6 mm) minimum thickness, minimum width and length 12 and 17 in. (0.3 and 0.4 m).

6.5 *Restraining Devices*, for coating sheet substrates while using knife applicators, restraining devices are required to maintain flatness.

6.5.1 *Machinists' Flat Magnetic Table*, recommended size 8 by 17 in. (0.2 by 0.4 m). (For steel only.)

6.5.2 *Vacuum Table*, minimum size 8 by 17 in. (0.2 by 0.4 m).

6.5.3 Whenever restraining devices in 6.5.1 and 6.5.2 are not available and knife applicators are to be used, sheet substrates can be rendered flat by taping their back sides to the plate-glass with 1 in. (25 mm) wide double-coated pressure-sensitive tape. The tape selected should allow removal of the sheets without creasing them.

6.6 *Pressure-Application Equipment*—Several methods for the application of pressure are provided. Selection is made by the user on the basis of field-use requirements.

6.6.1 *Static-Pressure-Application Equipment*—Hydraulic press: minimum capacity 5000 lb (23 000 N); minimum platen size 8 by 12 in. (0.2 by 0.3 m). Preferably, one of the platens should be mounted on a self-aligning joint. Both platens shall be ground flat and checked for parallelism and flatness with a machinist's straightedge.

6.6.2 *Rollers*—Steel rollers must be mounted on freely rotating axles; ball-bearing mounts are preferable. The roller design should conform generally with Fig. 3. Either of the two rollers specified may be used: a heavy roller 6 in. in diameter and 4 in. wide (155 mm in diameter by 100 mm wide) weighing 33 ± 1.0 lb (15 ± 0.5 kg); or a light roller 4-in.

⁴ Wire-wound applicators are available from the Leneta Co., PO Box 576 Ho-Ho-Kus, NJ 07423, from Byk Mallinckrodt Chemische Producte, 4230 Wessel Postfach 245, West Germany, and from Paul Gardner and Co. Inc., 218-D Commercial Blvd., Suite 205, Lauderdale-by-the-Sea, FL 33308-4491.

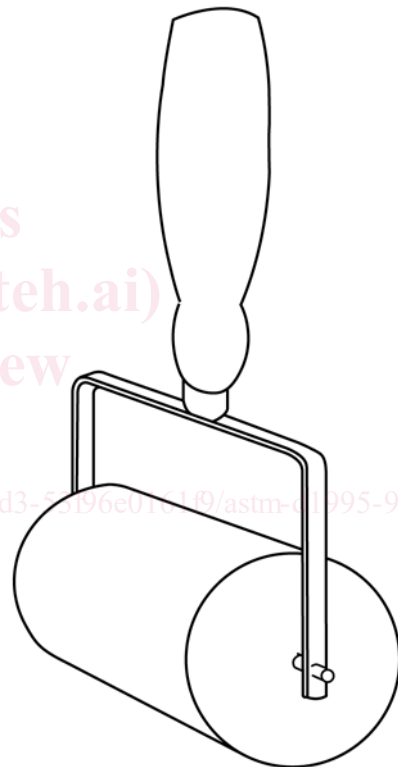

FIG. 3 Standard Steel Roller

diameter and 2.5 in. wide (100-mm diameter by 64 mm wide) weighing 10 ± 0.5 lb (4.5 ± 0.25 kg).

6.6.3 *Impact-Application Equipment*—The Bellows impact press consisting of a series B772-006 arbour stand and a “Bellows Air Motor” Series B8013.⁵ The “Bellows” impact press is shown in Fig. 4 and Fig. 5.

6.7 *Surfacing Machines for Solid Wood*—The following two types of wood-working machines are required to make solid-wood specimens that are flat and of an even thickness.

⁵ This equipment can be purchased from Bellows-Valvair, Akron, Ohio 44309. Also from the same company offices in Glendale, CA 91201 and Toronto, Canada.

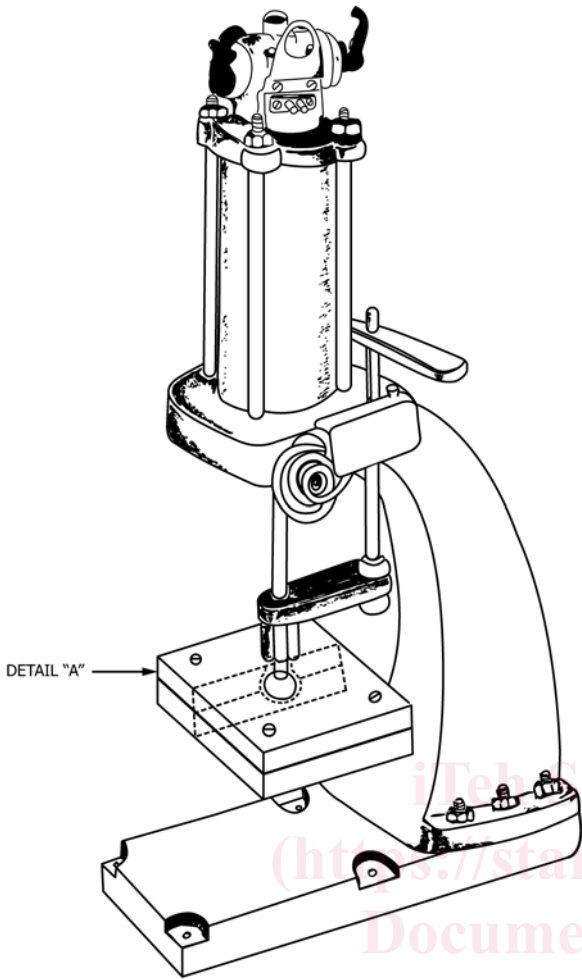

FIG. 4 The Bellows Air Valve Used for Impacting Peel Specimens

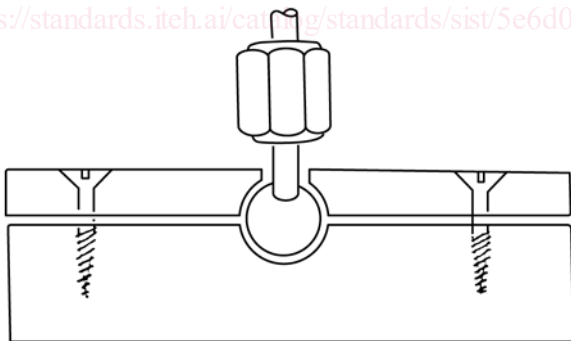

FIG. 5 Ball and Platen Assembly

6.7.1 A wood planer, sometimes referred to as a thickness planer. Any high-speed wood planer capable of producing a visibly smooth surface, free of any ripples or waves, and planks of equal thickness from end to end shall be acceptable.

6.7.2 A jointer-planer of sufficient width to accommodate 8-in. (20-cm) planks and that can be aligned to produce flat planks.

6.8 *Test Fixtures*—The fixtures described in the ASTM standards referenced in Section 2 were modified for the purposes of these test methods.

6.8.1 The climbing drum prescribed in Test Method D1781 has been modified according to Fig. 6, Fig. 7, Fig. 8, Fig. 9. The grooves in the drum customize it for use with the fixture in Fig. 8 by allowing the retaining lips on the fixturing device to fit into the grooves. This will unbalance the drum, but since controls are run and these are subtracted from the test results, the effect of the unbalance is nullified. The fixture in Fig. 8 is also a modification of the fixture in Fig. 4 of Test Method D1781. It does not require pre-drilling the test specimens.

6.8.2 The fixture required for the cleavage test, Fig. 10, is a modification of the fixture in Fig. 1 of Test Method D1062.

6.9 *Machinist's Straightedge*—A 12-in. (300-mm) machinist's straightedge (generally available from machinists' shops) is required. One of the lengthwise edges must be bevelled.

7. Test Materials

7.1 *Checking Flatness of Materials*—Lay the bevelled edge of a machinist's straightedge on the material perpendicular to its surface and along its width. While shining a bright light behind the straightedge, inspect the line of contact between the edge and the material. If the material is flat, no light should shine through. Make repeat observations at 2-in. (50-mm) intervals lengthwise. See Fig. 11.

7.1.1 *Material Dimensions*—See Table 1.

7.2 *Selection and Preparation of Maple Blocks*—Select hard maple blocks, kiln-dried, (*Acer saccharum* or *Acer nigrum*) having a minimum specific gravity of 0.65 based on oven-dry weight and volume, from planks that are of straight grain, that is, grain that runs parallel to the length of the plank, and free from defects including knots, birdseye, cross grain, decay, and any unusual discoloration. (See also Test Method D905.) Select pre-surfaced wood that is reasonably flat. To facilitate meeting the flatness requirements, condition the wood to be cut or surfaced to equilibrium moisture content at the same relative humidity and temperature selected for the coating operation. The cutting operations need not be performed under these temperature and humidity conditions, but it is strongly advised that the wood to be cut should be returned as quickly as possible to the temperature and humidity environment selected

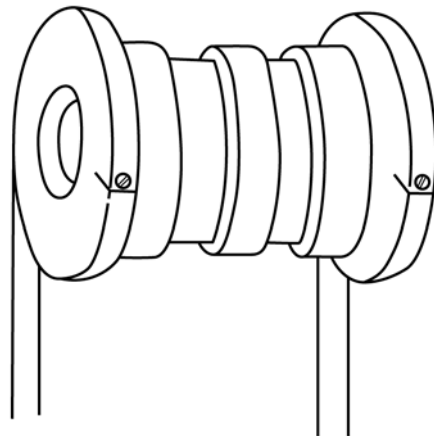

NOTE 1—Figures 6 and 7 show a drum that has been grooved to take in the fixturing lips of the fixture in Figs. 8 and 9.

FIG. 6 Climbing Peel Drum

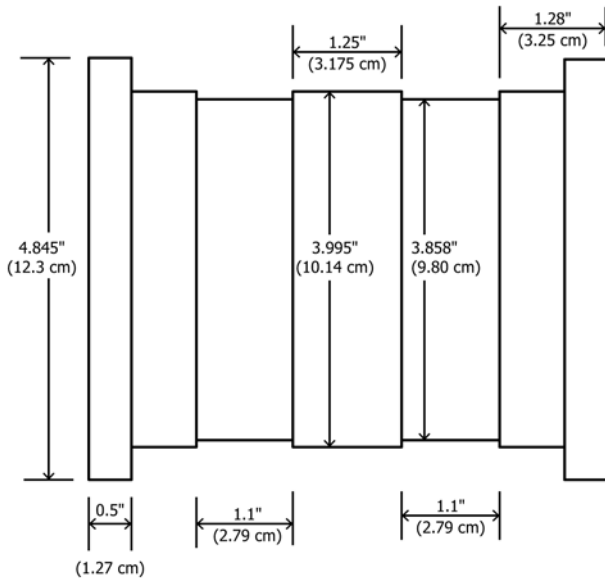

FIG. 7 Dimensions of Climbing Peel Drum

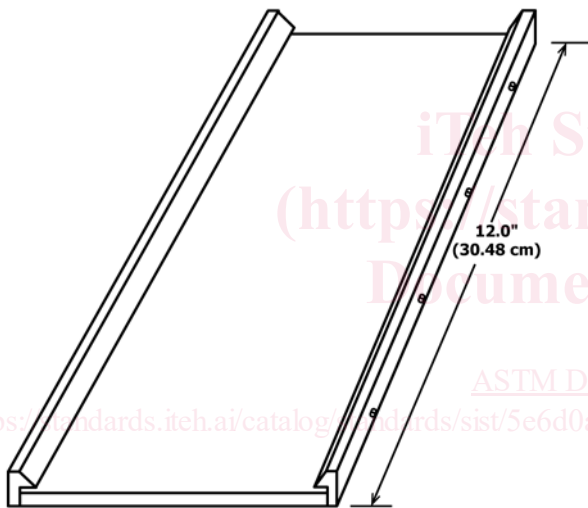

FIG. 8 End View of Specimen Holder for Climbing Drum Peel, Minus Specimen

for conditioning and coating. In this manner, changes in the moisture content of the wood that induce warping will be prevented. After moisture conditioning joint the surface to be bonded with a jointer-planer. Check the jointed surface for flatness with a machinist's straightedge. Then plane the opposite surface to the desired thickness with a thickness planer. Warping during storage can be minimized by stacking the wood with 3/4-in. (20-mm) spacers between planks. Restrain the ends by tying together cross pieces at the top and bottom of the bundle.

7.3 *Douglas Fir*—Solid wood Douglas fir blocks must have a minimum specific gravity of 0.4 based on oven-dry weight and volume. The grain must run parallel to the length of the plank, and be free from defects including knots, rosin exudations and discolorations within the test area. The same handling, storage, and flatness requirements apply as for hard

maple, see 7.2. See Table 1 for dimensions. (Take note that Douglas fir is not used in the cleavage test.)

7.4 Particleboard or flakeboard must have a minimum density of 45 lb/ft³ (0.73 g/cm³). As delivered, it should be flat. After cutting to size, verify the flatness of the board as in 7.1. Reject any non-flat pieces.

7.4.1 See 7.1.1 for dimensions, take note that flakeboard is not used in the cleavage test.

7.5 *Cold-Rolled Steel Sheets*—Inspect cut sheets for burrs and bends and file along the edges if necessary to remove any protrusions. Discard bent or creased sheets. Before use, vapor degrease in accordance with Guide D2651. Following degreasing, prepare specimens in accordance with Method D of Guide D2651. After degreasing, take care not to touch the surface to be bonded to avoid contamination and possible bond impairment.

NOTE 1—**Warning:** After degreasing, apply the autohesive within 1 h. Oxidation can occur in a very short time. Keep sheets that are not to be used within the hour immersed in water-free, pure, unused degreasing solvent, until ready for use.

7.6 *Sheet Aluminum:*

7.6.1 Any aluminum sheet alloy may be used. Typical sheet alloys are 2024-T3, 6061-T6, and 7075-T6.

7.6.2 Inspect cut sheets for burrs and bends and file along the edges if necessary to remove any protrusions. Discard bent or creased sheets. Follow by degreasing the sheets in accordance with 5.1 of Guide D2651. After degreasing, take care not to touch the surface to be bonded to avoid contamination and possible bond impairment.

7.7 *High-Pressure Laminate*—Sheets must be constructed of phenolic backing and melamine facings, formed at 1000 to 2000 psi (6.9 to 13.8 MPa). To be used as rigid adherends in the compression shear, climbing drum peel, and cleavage methods, the decorative face of the high-pressure laminate must first be bonded to another flat, rigid material such as hard maple, Douglas fir, or flakeboard. Prepare the decorative face for bonding by roughening with 120-grit abrasive paper. Take care not to touch the prepared surface to avoid contamination and possible bond impairment. For bonding, use any adhesive which is known to be stronger than the autohesive being tested. Epoxy, resorcinol-formaldehyde, and urea-formaldehyde adhesives have been found suitable. Furthermore, the adhesive should flow uniformly throughout the surface to prevent any uneven topography. Avoid using paste adhesives. To maintain the flatness of the plastic laminate/flakeboard assembly, carry out the curing operation on a press in accordance with 6.6.1, taking care that all surfaces that come in contact with the laminate backing are clean and free of oil and grease.

8. Strength Testing in Shear by Compression Loading (See Test Method D905)

8.1 The selections of adherends and pressure modes available in these test methods are shown in Table 1 and in Appendix X1 and Appendix X2. The strength of some of these materials may be inadequate for some autohesives under some test parameters. The materials listed rank as follows in decreasing order of strength: maple, Douglas-fir, flakeboard. Plastic

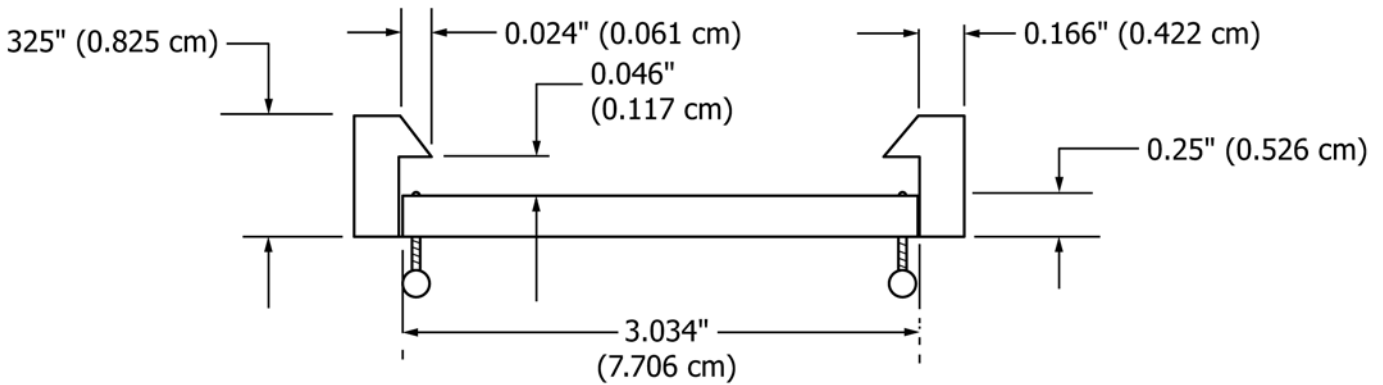

FIG. 9 Holding Fixture for 0.04 Steel Suitable for a Sample Width of 3.034 in. (7.706 cm)

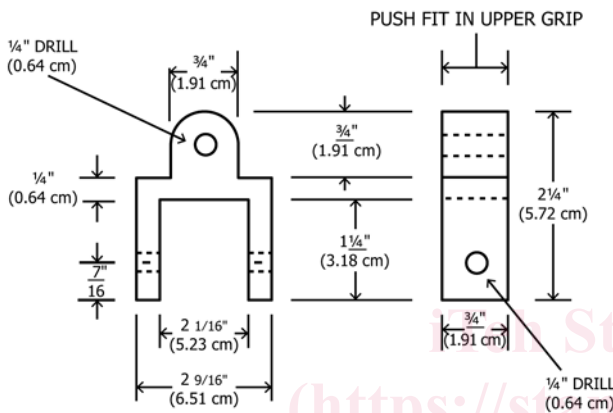

FIG. 10 Fixture for Cleavage Test

8.2 Select the relative humidity and temperature for conditioning the materials. (See also 7.2.) These conditions may also be set by agreement between the user and the party requiring these tests. In the $23 \pm 1^\circ\text{C}$ absence of any specific requirements, use the standard conditions ($73 \pm 2^\circ\text{F}$) and $50 \pm 2\%$ relative humidity given in Practice D1151. Maintain this environment while performing the operations described in 8.5, 8.6 (temperature only) 8.7, 8.8, 8.9, and 8.10.

8.3 Materials:

8.3.1 Precondition materials in the selected environment to equilibrium moisture content.

8.3.2 For dimensions see Table 1.

8.4 Surfacing, Precutting, Reassembling, and Reconditioning of Materials:

8.4.1 For wood and flakeboard see 7.1 and 7.2. In the precutting operation cut planks into the adherends proper (the centre pieces) and two side pieces that, when placed next to the adherends, serve as supports or riders for the knife applicator and also prevent the formation of irregularities on the surface edges upon drying of the autohesive.

8.4.2 Before precutting, make the pieces so that they can be later taped together in the same order. To avoid warping, remove the materials to be cut from the conditioning environment just prior to cutting, and cut only the materials that can be used in the same day. Precut each of the two planks along the length into three sections of which the center section shall be 2 in. (5 mm) wide. See Fig. 2, Fig. 11, and Fig. 12. Immediately after cutting, return all sections to the environment selected in 8.2.

8.5 Condition the materials for 1 h. Reassemble the materials at this time by laying all the pieces on the plate glass with the side to be bonded facing the glass. Tape all three sections together, first on the back and then edgewise, as in Fig. 12, taking care that the lengthwise edges of the sections are in tight contact with one another and that they maintain perfect surface alignment during the taping operation. Check the flatness of the taped assembly, as in 7.1. Reject it if it is not flat.

8.6 Condition the autohesive to the temperature selected in 8.2.

8.7 Application of the Autohesive, Beginning of the Open-Assembly Time—In a location free of air drafts place the taped assembly on the plate glass and recheck for flatness, as in 7.1,

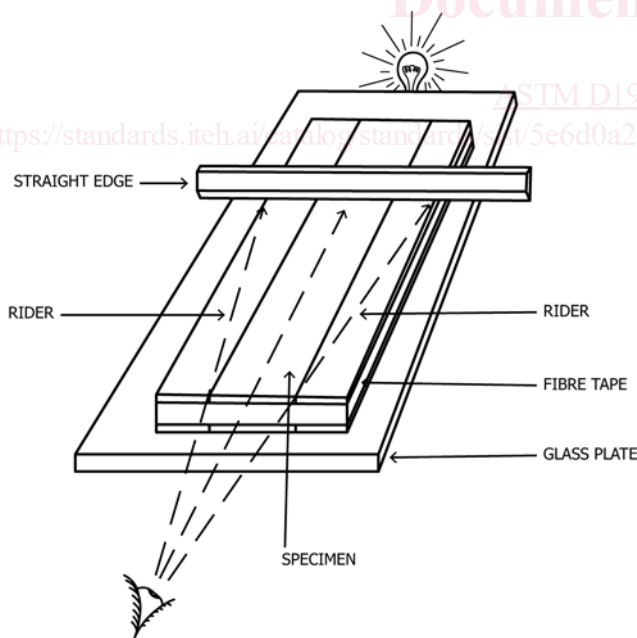

FIG. 11 Suspension for Flatness of Test Assembly Prior to Coating

laminates can be used in this test only by first laminating the decorative face of the laminate to one of the rigid materials as in 7.7.