



International  
Standard

**ISO 13506-1**

**Protective clothing against heat  
and flame —**

Part 1:

**Test method for complete  
garments — Measurement of  
transferred energy using an  
instrumented manikin**

*Habillement de protection contre la chaleur et les flammes —*

*Partie 1: Méthode d'essai pour vêtements complets — Mesurage  
de l'énergie transférée à l'aide d'un mannequin instrumenté*

**Second edition  
2024-06**

iTeh Standards  
(<https://standards.iteh.ai>)  
Document Preview

[ISO 13506-1:2024](https://standards.iteh.ai/catalog/standards/iso/ba138169-1e9d-4c36-96e1-3b5852febd84/iso-13506-1-2024)

<https://standards.iteh.ai/catalog/standards/iso/ba138169-1e9d-4c36-96e1-3b5852febd84/iso-13506-1-2024>



**COPYRIGHT PROTECTED DOCUMENT**

© ISO 2024

All rights reserved. Unless otherwise specified, or required in the context of its implementation, no part of this publication may be reproduced or utilized otherwise in any form or by any means, electronic or mechanical, including photocopying, or posting on the internet or an intranet, without prior written permission. Permission can be requested from either ISO at the address below or ISO's member body in the country of the requester.

ISO copyright office  
CP 401 • Ch. de Blandonnet 8  
CH-1214 Vernier, Geneva  
Phone: +41 22 749 01 11  
Email: [copyright@iso.org](mailto:copyright@iso.org)  
Website: [www.iso.org](http://www.iso.org)

Published in Switzerland

# Contents

	Page
<b>Foreword</b> .....	<b>v</b>
<b>Introduction</b> .....	<b>vi</b>
<b>1 Scope</b> .....	<b>1</b>
<b>2 Normative references</b> .....	<b>1</b>
<b>3 Terms and definitions</b> .....	<b>2</b>
<b>4 Overview</b> .....	<b>4</b>
4.1 General.....	4
4.2 Heat flux - energy balance on the sensor.....	4
4.3 Assumptions to achieve the required heat flux.....	5
<b>5 Apparatus</b> .....	<b>6</b>
5.1 Instrumented manikin.....	6
5.2 Posture of the manikin.....	9
5.3 Manikin sensors.....	10
5.3.1 Principle.....	10
5.3.2 Number of manikin sensors.....	11
5.3.3 Manikin sensor-measuring capability.....	12
5.3.4 Manikin sensor specification.....	12
5.3.5 Manikin sensor positioning.....	14
5.3.6 Manikin heat flux validation.....	14
5.4 Data acquisition system.....	16
5.5 Computer software program.....	16
5.5.1 General.....	16
5.5.2 Incident heat flux.....	17
5.5.3 Exposure heat flux.....	17
5.5.4 Thermal manikin protection factor (TMPF).....	17
5.5.5 Transferred energy.....	18
5.6 Flame exposure chamber.....	19
5.6.1 General.....	19
5.6.2 Chamber size.....	19
5.6.3 Chamber air flow.....	19
5.6.4 Chamber isolation.....	19
5.6.5 Chamber air exhaust system.....	19
5.6.6 Chamber safety devices.....	19
5.7 Fuel and delivery system.....	20
5.7.1 General.....	20
5.7.2 Fuel.....	20
5.7.3 Fuel delivery and shut-off system.....	20
5.7.4 Burner system.....	20
5.8 Image recording equipment.....	21
5.9 Safety checklist.....	21
5.10 Laboratory capability demonstration.....	22
<b>6 Sampling and test specimens</b> .....	<b>22</b>
6.1 General.....	22
6.2 Number of test specimens.....	22
6.3 Size of test specimen.....	22
6.4 Specimen preparation.....	23
6.4.1 Conditioning.....	23
6.4.2 Optional laundering.....	23
6.5 Standard reference garment design.....	23
<b>7 Pre-requisites for products implementing this test method</b> .....	<b>24</b>
<b>8 Procedure</b> .....	<b>25</b>
8.1 Preparation of test apparatus.....	25

# ISO 13506-1:2024(en)

8.1.1	General	25
8.1.2	Manikin sensor check	25
8.1.3	Flame exposure chamber purging	26
8.1.4	Confirming safe operation conditions and lighting of pilot flames	26
8.1.5	Gas line charging	26
8.1.6	Confirmation of nude and garment exposure conditions	26
8.2	Specimen testing procedure	27
8.2.1	General	27
8.2.2	Dressing the manikin	27
8.2.3	Recording the specimen identification, test conditions and test observations	28
8.2.4	Starting the image recording system	28
8.2.5	Setting time for heat transfer data acquisition	29
8.2.6	Exposure of the test specimen	29
8.2.7	Recording of specimen response remarks	29
8.2.8	Calculation of surface incident heat flux and transferred energy	29
8.2.9	Still images	29
8.3	Preparing for the next test exposure	29
<b>9</b>	<b>Test report</b>	<b>30</b>
9.1	General	30
9.2	Specimen identification	30
9.3	Exposure conditions	30
9.4	Results for each specimen	31
9.4.1	General	31
9.4.2	Heat flux data of each manikin sensor	31
9.4.3	Thermal manikin protection factor	31
9.4.4	Transferred energy	31
9.4.5	Other information that may be reported	32
9.5	Observations	32
<b>Annex A (informative) Considerations for conducting tests and using test results</b>		<b>33</b>
<b>Annex B (informative) Interlaboratory test data analysis</b>		<b>34</b>
<b>Annex C (normative) Calibration and validation procedure</b>		<b>36</b>
<b>Annex D (informative) Burner stand alignment for flame engulfment</b>		<b>39</b>
<b>Annex E (informative) Elements of a computer software program</b>		<b>42</b>
<b>Bibliography</b>		<b>44</b>

## Foreword

ISO (the International Organization for Standardization) is a worldwide federation of national standards bodies (ISO member bodies). The work of preparing International Standards is normally carried out through ISO technical committees. Each member body interested in a subject for which a technical committee has been established has the right to be represented on that committee. International organizations, governmental and non-governmental, in liaison with ISO, also take part in the work. ISO collaborates closely with the International Electrotechnical Commission (IEC) on all matters of electrotechnical standardization.

The procedures used to develop this document and those intended for its further maintenance are described in the ISO/IEC Directives, Part 1. In particular, the different approval criteria needed for the different types of ISO documents should be noted. This document was drafted in accordance with the editorial rules of the ISO/IEC Directives, Part 2 (see [www.iso.org/directives](http://www.iso.org/directives)).

ISO draws attention to the possibility that the implementation of this document may involve the use of (a) patent(s). ISO takes no position concerning the evidence, validity or applicability of any claimed patent rights in respect thereof. As of the date of publication of this document, ISO had not received notice of (a) patent(s) which may be required to implement this document. However, implementers are cautioned that this may not represent the latest information, which may be obtained from the patent database available at [www.iso.org/patents](http://www.iso.org/patents). ISO shall not be held responsible for identifying any or all such patent rights.

Any trade name used in this document is information given for the convenience of users and does not constitute an endorsement.

For an explanation of the voluntary nature of standards, the meaning of ISO specific terms and expressions related to conformity assessment, as well as information about ISO's adherence to the World Trade Organization (WTO) principles in the Technical Barriers to Trade (TBT), see [www.iso.org/iso/foreword.html](http://www.iso.org/iso/foreword.html).

This document was prepared by Technical Committee ISO/TC 94, *Personal safety — Protective clothing and equipment*, Subcommittee SC 13, *Protective clothing*, in collaboration with the European Committee for Standardization (CEN) Technical Committee CEN/TC 162, *Protective clothing including hand and arm protection and lifejackets*, in accordance with the Agreement on technical cooperation between ISO and CEN (Vienna Agreement).

This second edition cancels and replaces the first edition (ISO 13506-1:2017), which has been technically revised.

The main changes are as follows:

- revision of definitions (see [Clause 3](#));
- heat flux, requirements and its definition (see [Clauses 4](#) and [5](#));
- female manikin (see [Clause 5](#) and rest of document);
- manikin sensor calibration (see [Clause 5](#));
- heat flux symmetry (see [Clause 5](#));
- thermal manikin protection factor (TMPF) (see [Clause 5](#));
- transferred energy and its calculation (see [Clause 5](#));
- interlaboratory test data analysis results (see [Annex B](#));
- calibration and validation procedure (see [Annex C](#)).

A list of all parts in the ISO 13506 series can be found on the ISO website.

Any feedback or questions on this document should be directed to the user's national standards body. A complete listing of these bodies can be found at [www.iso.org/members.html](http://www.iso.org/members.html).

## Introduction

The purpose of heat and flame-resistant protective clothing is to shield the wearer from hazards that can cause skin burn injury. The clothing is made from one or more materials. The evaluation of materials for potential use in this type of clothing generally involves two steps. First, the materials are tested to gauge their ability to limit flame spread. They are then tested to determine the rate of transferred energy through them when exposed to a particular hazard. A variety of bench scale test methods are used in these two steps. Bench scale test methods permit testing fabrics, seams, zippers, pockets, badges, buttons or other closures, metal and plastic clips or other features that can be included in a complete garment. Once suitable materials are identified, they are made into complete garments or ensembles. The overall design and performance of the garment can be assessed on a manikin-fire exposure system. This test method is not designed to measure material properties directly, but to evaluate the interaction of material behaviour and garment design.

In this test method, a stationary, upright adult-sized manikin (male or female) is dressed in a complete garment and exposed to a laboratory simulation of a fire with controlled heat flux, duration and flame distribution. The average incident heat flux to the exterior of the garment is  $84 \text{ kW/m}^2$ , a value similar to those used in ISO 9151, ISO 6942 and ISO 17492. The protection offered by the test specimens is evaluated through quantitative measurements and observations. Heat flux sensors fitted to the surface of the manikin are used to measure the heat flux variation with time and location on the manikin and to determine the total energy absorbed over the data-gathering period. The data gathering period is selected to ensure that the total energy transferred has been completed. These measurements are suitable for use in predicting skin burn injury (see ISO 13506-2).

The fire simulations are dynamic. The heat flux resulting from the exposure is neither constant nor uniform over the surface of the manikin/garment. Under these conditions, the results are expected to have more variability than carefully controlled bench scale tests (interlaboratory results are found in [Annex B](#)).

Fit of the garment on the manikin is important. Variations in garment design and how the manikin is dressed by the operator can influence the test results. A test garment or specimen size is selected by the laboratory from the size range provided by the manufacturer to properly fit the laboratory's manikin. Variations in the fit of the test garment that can occur when sitting, bending or moving are not evaluated.

Most manikins do not have sensors on the hands and feet, but it is possible to assess some aspects of hand protection depending upon the specific design of the hands. All manikins contain heat flux sensors in the head. The reason for this is that many outer garments include an integral hood, but not gloves or footwear. Tests for gloves and footwear are covered by other ISO documents for specific end uses.

The method described in this document as an optional part in the fire fighter standards ISO 11999-3, EN 469<sup>[11]</sup> and as an optional part in the industrial heat and flame protective clothing standard ISO 11612. The National Fire Protection Association (NFPA) specifies a test method similar to the one described in this document as part of a certification process for garments (see NFPA 2112<sup>[13]</sup>).

# Protective clothing against heat and flame —

## Part 1: Test method for complete garments — Measurement of transferred energy using an instrumented manikin

### 1 Scope

This document specifies the overall requirements, equipment and calculation methods to provide results that can be used for evaluating the performance of complete garments or protective clothing ensembles exposed to short duration flame engulfment.

This test method establishes a rating system to characterize the thermal protection provided by single-layer and multi-layer garments made of flame resistant materials. The rating is based on the measurement of heat transfer to a full-size manikin exposed to convective and radiant energy in a laboratory simulation of a fire with controlled heat flux, duration and flame distribution. The heat transfer data is summed over a prescribed time to give the total transferred energy. Transferred energy and thermal manikin protection factor (TMPF) assessment methods provide a means to quantify product performance.

The exposure heat flux is limited to a nominal level of 84 kW/m<sup>2</sup> and durations of 3 s to 20 s dependant on the risk assessment and expectations from the thermal insulating capability of the garment.

The results obtained apply only to the particular garments or ensembles, as tested, and for the specified conditions of each test, particularly with respect to the heat flux, duration and flame distribution.

This test method covers visual evaluation, observation, inspection and documentation on the overall behaviour of the test specimen(s) before, during and after the exposure. The effects of body position and movement are not addressed in this test method.

The heat flux measurements can also be used to calculate the predicted skin burn injury resulting from the exposure (see ISO 13506-2).

This test method does not simulate high radiant exposures such as those found in arc flash exposures, some types of fire exposures where liquid or solid fuels are involved, nor exposure to nuclear explosions.

**NOTE** This test method is complex and requires a high degree of technical expertise in both the test setup and operation. Even minor deviations from the instructions in this test method can lead to significantly different test results.

### 2 Normative references

The following documents are referred to in the text in such a way that some or all of their content constitutes requirements of this document. For dated references, only the edition cited applies. For undated references, the latest edition of the referenced document (including any amendments) applies.

ISO 3801, *Textiles — Woven fabrics — Determination of mass per unit length and mass per unit area*

ISO 11610, *Protective clothing — Vocabulary*

ISO 13506-2:2024, *Protective clothing against heat and flame — Part 2: Skin burn injury prediction — Calculation requirements and test cases*

ISO/IEC 17025, *General requirements for the competence of testing and calibration laboratories*

### 3 Terms and definitions

For the purposes of this document, the terms and definitions given in ISO 11610 and the following apply.

ISO and IEC maintain terminology databases for use in standardization at the following addresses:

- ISO Online browsing platform: available at <https://www.iso.org/obp>
- IEC Electropedia: available at <https://www.electropedia.org/>

#### 3.1 absorbed energy

$q_{\text{net}}$   
net *energy* (3.7) absorbed by the sensor that accounts for all modes of heat transfer interacting with the sensor surface when exposed to the *incident energy* (3.16)

Note 1 to entry: The energy balance including losses unique for each sensor type are detailed in the respective sensor technology documents.

Note 2 to entry: See [Figure 1](#) in [4.2](#) for a schematic representation of this definition.

#### 3.2 associated area area of body region per sensor

Note 1 to entry: See [Table 3](#).

#### 3.3 data acquisition period time elapsed during which data is recorded during a test

#### 3.5 data calculation period defined time over which data are used for a calculation

#### 3.6 conditioning keeping samples under standard conditions of temperature and relative humidity for a minimum period of time

#### 3.7 energy *heat flux* (3.13) integrated over a specified time period multiplied by *associated area* (3.2)

Note 1 to entry: Energy is expressed in joules (J).

#### 3.8 exposure duration exposure time time from the initial opening of the valves nearest to the burner to the closing of the same valve (8.2.6.)

#### 3.9 exposure heat flux incident heat flux averaged among the manikin sensors during data calculation period

#### 3.10 fire rapid oxidation process which is a chemical reaction of fuel and oxygen resulting in the evolution of light, heat and combustion products in varying intensities

Note 1 to entry: The fuel can be a form of solid, dust, aerosol or a gas of an ignitable substance. The fire will last as long as there is a combustible fuel-air mixture.



### 3.11

#### **flame distribution**

spatial distribution of the flame engulfment from the test facility burners which provides a controlled *exposure heat flux* (3.9) over the manikin surface

### 3.12

#### **garment ease**

difference between body (manikin) dimensions and garment dimensions

### 3.13

#### **heat flux**

heat through a surface area perpendicular to the direction of heat flow

Note 1 to entry: Heat flux is expressed in kW/m<sup>2</sup>. For any conversion from kW/m<sup>2</sup> to cal/cm<sup>2</sup>.s; the following ratio is to be used 4,184 J = 1 cal.

#### 3.13.1

##### **absorbed heat flux**

net *heat flux* (3.13) absorbed by the sensor that accounts for all modes of heat transfer interacting with the sensor surface when exposed to the *incident heat flux* (3.13.2)

#### 3.13.2

##### **incident heat flux**

*heat flux* (3.13) to which a test item or sensor is exposed

Note 1 to entry: for incident heat flux to manikin sensors, see fig on energy balance (4.2)

### 3.14

#### **heat flux sensor**

##### **manikin sensor**

device, fulfilling the requirements of this document, capable of measuring the *heat flux* (3.13) to the manikin's surface under test conditions, or of providing data that can be used to calculate the heat flux

### 3.15

#### **incident energy**

*energy* (3.7) to which a sensor is exposed during a *nude exposure* (3.18)

<https://standards.iteh.ai/catalog/standards/iso/ba138169-1e9d-4c36-96e1-3b5852febd84/iso-13506-1-2024>

#### 3.15.1

##### **total incident energy**

sum of the *incident energy* (3.16) of a specified set of *manikin sensors* (3.15) during the nude exposure for the specified time period

### 3.16

#### **instrumented manikin**

model representing an adult-sized human (male or female) which is fitted with *manikin sensors* (3.15) in the surface

### 3.17

#### **nude exposure**

test performed on the uncovered surface of the *instrumented manikin* (3.17)

### 3.18

#### **maximum absorbed heat flux**

highest value of *absorbed heat flux* (3.13.1) calculated from the recorded output of a *manikin sensor* (3.15) during a test

### 3.19

#### **transferred energy**

*absorbed energy* (3.1) by a single sensor under the test item

Note 1 to entry: Each manikin sensor has an *associated area* (3.2). It is assumed that the measured energy transferred for each manikin sensor is uniform over this associated area. Some manikins have a sensor layout that has the same area associated with each manikin sensor, others do not.

### 3.19.1

#### **total transferred energy**

sum of the *transferred energy* (3.20) of a specified set of covered *manikin sensors* (3.15) over the *data calculation period* (3.5)

Note 1 to entry: Total transferred energy can refer to either the whole covered area of the manikin or to a specific covered manikin region.

### 3.20

#### **thermal manikin protection factor**

#### **TMPF**

factor representing the overall protective garment or ensemble performance as a function of exposure and test specimen mass

## 4 Overview

### 4.1 General

The method evaluates the thermal protective performance of the test specimen, which is either a garment or an ensemble. The protective performance is a function of both the materials of construction and design. The average incident heat flux is 84 kW/m<sup>2</sup> with an exposure duration of 3 s to 20 s.

The performance standard shall indicate all the necessary boundary conditions of the test such as but not limited to pass/fail criteria, the exposure time, test garment preparation, the minimum number of samples to be tested, etc. (see [Clause 7](#)).

The conditioned test specimen is placed on a stationary upright adult-size manikin and exposed to a laboratory simulation of a fire with controlled heat flux, duration and flame distribution. The test procedure, data acquisition, result calculations and preparation of the test report are performed with computer hardware and software programs (see [Annex E](#)).

Energy transferred through the test specimen during and after the exposure is measured by manikin sensors<sup>[15][16]</sup>. These measurements shall be used to calculate the total energy transferred to the surface of the manikin.

NOTE 1 The results are used to calculate the degree of predicted skin burn injury and total predicted skin burn injury areas resulting from the exposure as described in ISO 13506-2. The predicted skin burn injury information is used in the calculation of the thermal manikin protection factor.

Identification of the test garment, test conditions, comments and response of the test specimen to the exposure are recorded and are included as part of the test report. The performance of the test specimen is indicated by the calculated total transferred energy through the test specimen over the data acquisition period, thermal manikin protection factor (TMPF) and the way the test specimen responds to the test exposure.

NOTE 2 This test method can be used for other purposes such as for research on fabrics and garment designs, comparison of garment ensembles, or evaluation of any garment or ensemble to particular applications or end use standards or specifications.

### 4.2 Heat flux - energy balance on the sensor

When energy from flames impinges a manikin sensor, its energy balance of convective heat and radiant heat on the surface of the manikin sensor and the losses - it is critical to using the right calibration techniques

and making the adequate correction (see [Annex C](#)). The energy definitions in [clause 3](#) are better understood when looking at [Figure 1](#). When a garment covers the sensor or even touches the sensor, a number of additional factors apply which are described in more detail in [C.3](#).

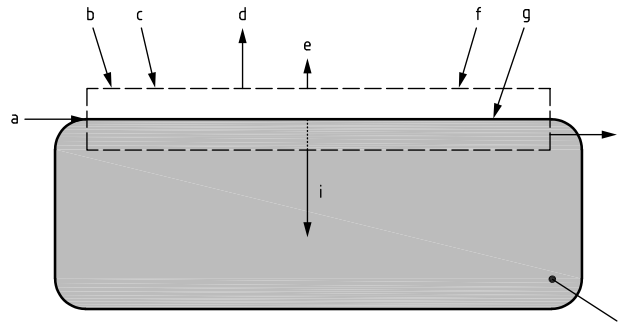

a	Control volume.	f	$q_{\text{convection}}$ .
b	$q_{\text{inc, radiant}}$ .	g	$T_{\text{surface}}$ .
c	$q_{\text{inc, radiant walls}}$ .	h	$q_{\text{losses}}$ .
d	$q_{\text{inc, radiant reflected}}$ .	i	$q_{\text{net}}$ .
e	$q_{\text{emitted, radiant}}$ .	j	Sensing surface.

**Figure 1 — Energy balance on the surface of a manikin sensor**

$$q_{\text{net}} = \alpha q_{\text{inc, radiant}} + \alpha q_{\text{inc, radiant, walls}} + q_{\text{inc, convective}} - q_{\text{radiant, emitted}} - q_{\text{losses}} \quad (1)$$

where

$q_{\text{net}}$	net absorbed heat flux by the surface;
$\alpha$	absorptivity of the surface;
$q_{\text{inc, radiant}}$	the radiant heat flux striking the sensor surface from the flame;
$q_{\text{inc, radiant, walls}}$	the radiant heat flux striking the sensor surface from the walls;
$q_{\text{inc, convective}}$	convection heat from the flame to the sensor surface [ $h(T_{\text{flame}} - T_{\text{surface}})$ ], where $h$ = convection heat transfer coefficient, $\text{W/m}^2\cdot\text{°C}$ ;
$q_{\text{radiant, emitted}}$	radiant heat flux emitted by the sensor surface to the flame and surroundings [ $\epsilon\sigma T^4$ ], where $\epsilon = \alpha$ (Kirchhoff's law), $\sigma$ = Stefan Boltzmann constant, and $T$ is in K;
$q_{\text{losses}}$	heat losses from the side and back of the sensor due to its mounting in the manikin shell (specific to each sensor technology).

The  $q_{\text{inc, radiant}}$  reflected shown in [Figure 1](#), does not heat the sensor surface. It is included in [Figure 1](#) for completeness of the energy flows between the flame and the sensor surface. The amount reflected equals  $(1 - \alpha) q_{\text{inc, radiant}}$ .

### 4.3 Assumptions to achieve the required heat flux

For the purposes of this test, the following conditions are assumed when calculating the incident heat flux:

- the heat is 60 % radiative and 40 % convective (Kemp et al.)[\[18\]](#);
- the temperature of the flame on the manikin is 1 100 °C;
- the paint used to cover the surface of the thermal energy sensor has an  $\alpha = 0,9$ .

NOTE Different sensors react differently to the incident energy (approximately 40 % convective energy in the incident nude exposure). Take care when making corrections for absorbed energy under the test specimen as the air gap between the inside of the garment and the sensor as the distribution of heat flux (conduction, radiant, and convection) is unknown and could result in a higher or lower protection value attributed to the fabric or ensemble.

## 5 Apparatus

### 5.1 Instrumented manikin

An upright manikin in the shape and size of a female or male adult human shall be used [see [Figure 2](#)]. The manikin shall consist of a head, a chest/back, an abdomen/buttocks, arms, hands, legs and feet. Representative dimensions are provided for the male form in [Table 1](#) and for the female form in [Table 2](#). [Figure 3](#) contains a visual key of dimension locations

The arms should be able to rotate through a sufficient arc at the shoulder to ease the garment donning and doffing on the manikin.

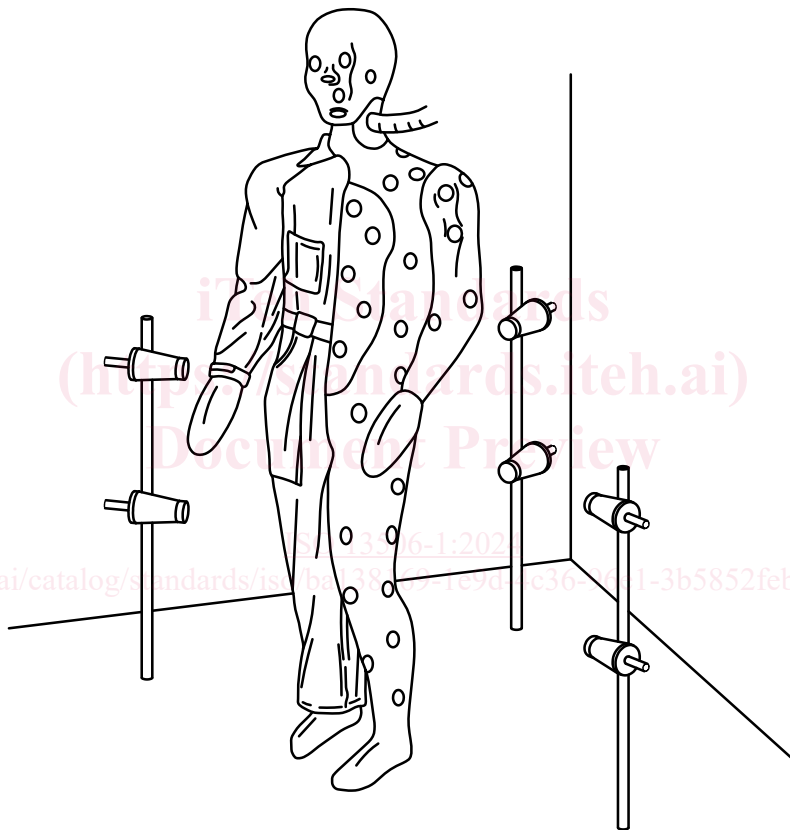

**Figure 2 — Example of an instrumented thermal manikin and partial view of torch stands (burner system)**

NOTE 1 Only six burners of the total are shown in [Figure 2](#) (see [5.7.4](#)).

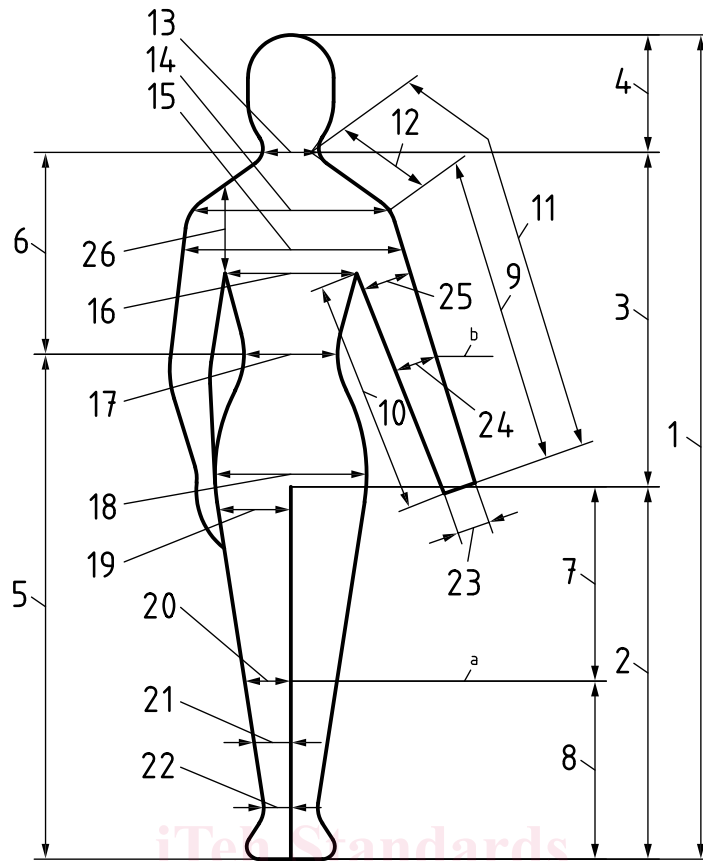

- a Knee level.
- b Elbow level.

iTech Standards  
 (https://standards.itih.ai)  
 Document Preview

**Figure 3 — Manikin measurement locations**

ISO 13506-1:2024

NOTE 2 The instrumented manikin matches the dimensions given in Table 1 (male form), Table 2 (female form). The key to the numbers referenced in Figure 3 correspond to the measurements in both Tables.

**Table 1 — Measurements for an adult male manikin**

No	Description of male manikin <sup>a</sup>	Measurement mm	Tolerance mm
1	Stature/total height	1 810	±60
2	Inside leg height (crotch height, from heel) (about 7+8)	880	±75
3	Center trunk length (from back of neck to crotch back to front neck)	1 560	±60
4	Head height, including neck (Top point of head to side of neck point)	255	±45
5	Waist height, from heel	1 125	±50
6	Collarbone to back waist (Front neck point to waist)	480	±70
7	Crotch to knee	330	±45
8	Knee height, standing	530	±70
9	Top of shoulder to wrist along arm (shoulder to wrist, elbow bent)	585	±75
10	Under arm length (Arm inseam)	470	±40
11	Back neck point to wrist length, 3-point measurement from between collarbones to wrist 3 (shoulder to elbow, elbow bent) (about 9+12)	785	±65
12	Shoulder length (from side of neck to shoulder point)	170	±75
13	Neck girth (circumference)	420	±60

ISO 13506-1:2024(en)

Table 1 (continued)

No	Description of male manikin <sup>a</sup>	Measurement mm	Tolerance mm
14	Across back shoulder width (from one shoulder across back to other shoulder through back of neck point)	500	±90
15	Chest girth, (100 mm down from front neck point)	475	±95
16	Chest circumference, at the armpits	995	±105
17	Waist girth	870	±25
18	Maximum hip girth	1 015	±15
19	Thigh girth below the gluteal fold	590	±40
20	Knee girth	390	±50
21	Calf girth (maximum horizontal girth)	400	±30
22	Ankle girth(measured at minimum leg girth)	280	±30
23	Wrist girth	205	±30
24	Elbow girth	290	±25
25	Upper arm girth, at midpoint between shoulder point and elbow point	320	±35
26	Armscye girth	410	±50

NOTE The descriptions for measurements areas are based on the ISO 8559-series.

<sup>a</sup> Manikins meeting these requirements are available from:

- Composites USA, 1 Peninsula Drive, Northeast, Maryland, USA. Ph. +1 302 834 7712,
- Precision Products LLC, 7400 Whitepine Road, Richmond, Virginia, USA, Ph. +1 804 561 0777,
- Thermetrics, LLC, 4220 - 24th Avenue West, Seattle, WA 98199, USA,
- MYAC Consulting Inc., 23046 Township Road 514, Sherwood Park, AB, T8B 1K9, Canada.

This information is given for the convenience of users of this document and does not constitute an endorsement by ISO. Equivalent products may be used if they can be shown to lead to the same results.

Table 2 — Measurements for an adult female manikin

No	Description of female manikin <sup>a</sup>	Measurement mm	Tolerance mm
1	Stature/total height	1 612	±55
2	Inside leg height (crotch height, from heel) (about 7+8)	788	±50
3	Center trunk length (from back of neck to crotch back to front neck)	1 503	±55
4	Head height, including neck (Top point of head to side of neck point)	230	±45
5	Waist height, from heel	981	±45
6	Collarbone to back waist (Front neck point to waist)	405	±60
7	Crotch to knee	352	±40
8	Knee height, standing	437	±40
9	Top of shoulder to wrist along arm (shoulder to wrist, elbow bent)	580	±50
10	Under arm length (Arm inseam)	422	±30
11	Back neck point to wrist length, 3-point measurement from between collarbones to wrist (shoulder to elbow, elbow bent) (about 9+12)	685	±65
12	Shoulder length (from side of neck to shoulder point)	104	±55
13	Neck girth (circumference)	373	±45
14	Across back shoulder width (from one shoulder across back to other shoulder through back of neck point)	445	±75
15	Across chest, (100 mm down)		
16	Chest circumference, at the armpits	952	±80
17	Waist girth	827	±60