



Designation: G134 – 95 (Reapproved 2010)<sup>e1</sup>

## Standard Test Method for Erosion of Solid Materials by Cavitating Liquid Jet<sup>1</sup>

This standard is issued under the fixed designation G134; the number immediately following the designation indicates the year of original adoption or, in the case of revision, the year of last revision. A number in parentheses indicates the year of last reapproval. A superscript epsilon ( $\epsilon$ ) indicates an editorial change since the last revision or reapproval.

<sup>e1</sup> NOTE—Updated Section 3 to reflect Terminology G40–10b editorially in December 2010.

### 1. Scope

1.1 This test method covers a test that can be used to compare the cavitation erosion resistance of solid materials. A submerged cavitating jet, issuing from a nozzle, impinges on a test specimen placed in its path so that cavities collapse on it, thereby causing erosion. The test is carried out under specified conditions in a specified liquid, usually water. This test method can also be used to compare the cavitation erosion capability of various liquids.

1.2 This test method specifies the nozzle and nozzle holder shape and size, the specimen size and its method of mounting, and the minimum test chamber size. Procedures are described for selecting the standoff distance and one of several standard test conditions. Deviation from some of these conditions is permitted where appropriate and if properly documented. Guidance is given on setting up a suitable apparatus, test and reporting procedures, and the precautions to be taken. Standard reference materials are specified; these must be used to verify the operation of the facility and to define the normalized erosion resistance of other materials.

1.3 Two types of tests are encompassed, one using test liquids which can be run to waste, for example, tap water, and the other using liquids which must be recirculated, for example, reagent water or various oils. Slightly different test circuits are required for each type.

1.4 This test method provides an alternative to Test Method G32. In that method, cavitation is induced by vibrating a submerged specimen at high frequency (20 kHz) with a specified amplitude. In the present method, cavitation is generated in a flowing system so that both the jet velocity and the downstream pressure (which causes the bubble collapse) can be varied independently.

1.5 The values stated in SI units are to be regarded as standard. No other units of measurement are included in this standard.

1.6 *This standard does not purport to address all of the safety concerns, if any, associated with its use. It is the responsibility of the user of this standard to establish appropriate safety and health practices and determine the applicability of regulatory limitations prior to use.*

### 2. Referenced Documents

#### 2.1 ASTM Standards:<sup>2</sup>

- A276 Specification for Stainless Steel Bars and Shapes
- B160 Specification for Nickel Rod and Bar
- B211 Specification for Aluminum and Aluminum-Alloy Rolled or Cold Finished Bar, Rod, and Wire
- D1193 Specification for Reagent Water
- E691 Practice for Conducting an Interlaboratory Study to Determine the Precision of a Test Method
- G32 Test Method for Cavitation Erosion Using Vibratory Apparatus
- G40 Terminology Relating to Wear and Erosion
- G73 Test Method for Liquid Impingement Erosion Using Rotating Apparatus

#### 2.2 ASTM Adjuncts:

- Manufacturing Drawings of the Apparatus<sup>3</sup>

### 3. Terminology

3.1 See Terminology G40 for definitions of terms relating to cavitation erosion. For convenience, definitions of some important terms used in this test method are reproduced below.

#### 3.2 Definitions:

3.2.1 *cavitation, n*—the formation and subsequent collapse, within a liquid, of cavities or bubbles that contain vapor or a mixture of vapor and gas.

3.2.1.1 *Discussion*—Cavitation originates from a local decrease in hydrostatic pressure in the liquid, usually produced by motion of the liquid (see **flow cavitation**) or of a solid

<sup>1</sup> This test method is under the jurisdiction of ASTM Committee G02 on Wear and Erosion and is the direct responsibility of Subcommittee G02.10 on Erosion by Solids and Liquids.

Current edition approved Dec. 1, 2010. Published December 2010. Originally approved in 1995. Last previous edition approved in 2006 as G134–95(2006). DOI: 10.1520/G0134-95R10E01.

<sup>2</sup> For referenced ASTM standards, visit the ASTM website, www.astm.org, or contact ASTM Customer Service at service@astm.org. For *Annual Book of ASTM Standards* volume information, refer to the standard's Document Summary page on the ASTM website.

<sup>3</sup> Available from ASTM International Headquarters. Order Adjunct No. ADJG0134.

boundary (see **vibratory cavitation**). It is distinguished in this way from boiling, which originates from an increase in liquid temperature.

3.2.1.2 *Discussion*—The term cavitation, by itself, should not be used to denote the damage or erosion of a solid surface that can be caused by it; this effect of cavitation is termed **cavitation damage** or **cavitation erosion**. To erode a solid surface, bubbles or cavities must collapse on or near that surface. **G40**

3.2.2 *cavitation erosion, n*—progressive loss of original material from a solid surface due to continued exposure to cavitation. **G40**

3.2.3 *cumulative erosion, n—in cavitation and impingement erosion*, the total amount of material lost from a solid surface during all exposure periods since it was first exposed to cavitation or impingement as a newly-finished surface. (More specific terms that may be used are *cumulative mass loss*, *cumulative volume loss*, or *cumulative mean depth of erosion*. See also **cumulative erosion-time curve**.)

3.2.3.1 *Discussion*—Unless otherwise indicated by the context, it is implied that the conditions of cavitation or impingement have remained the same throughout all exposure periods, with no intermediate refinishing of the surface. **G40**

3.2.4 *cumulative erosion rate, n*—the cumulative erosion at a specified point in an erosion test divided by the corresponding cumulative exposure duration; that is, the slope of a line from the origin to the specified point on the cumulative erosion-time curve. (*Synonym*: **average erosion rate**) **G40**

3.2.5 *cumulative erosion-time curve, n—in cavitation and impingement erosion*, a plot of cumulative erosion versus cumulative exposure duration, usually determined by periodic interruption of the test and weighing of the specimen. This is the primary record of an erosion test. Most other characteristics, such as the incubation period, maximum erosion rate, terminal erosion rate, and erosion rate-time curve, are derived from it. **G40**

3.2.6 *flow cavitation, n*—cavitation caused by a decrease in local pressure induced by changes in velocity of a flowing liquid. Typically, this may be caused by flow around an obstacle or through a constriction, or relative to a blade or foil. A cavitation cloud or “cavitating wake” generally trails from some point adjacent to the obstacle or constriction to some distance downstream, the bubbles being formed at one place and collapsing at another. **G40**

3.2.7 *incubation period, n—in cavitation and impingement erosion*, the initial stage of the erosion rate-time pattern during which the erosion rate is zero or negligible compared to later stages. Also, the exposure duration associated with this stage. (Quantitatively it is sometimes defined as the intercept on the time or exposure axis, of a straight line extension of the maximum-slope portion of the cumulative erosion-time curve.) **G40**

3.2.8 *maximum erosion rate, n—in cavitation and liquid impingement erosion*, the maximum instantaneous erosion rate in a test that exhibits such a maximum followed by decreasing erosion rates. (See also **erosion rate-time pattern**.)

3.2.8.1 *Discussion*—Occurrence of such a maximum is

typical of many cavitation and liquid impingement tests. In some instances, it occurs as an instantaneous maximum, in others as a steady-state maximum which persists for some time. **G40**

3.2.9 *normalized erosion resistance,  $N_e$ , n—in cavitation and liquid impingement erosion*, a measure of the erosion resistance of a test material relative to that of a specified reference material, calculated by dividing the volume loss rate of the reference material by that of the test material, when both are similarly tested and similarly analyzed. By “similarly analyzed,” it is meant that the two erosion rates must be determined for corresponding portions of the erosion rate time pattern; for instance, the maximum erosion rate or the terminal erosion rate.

3.2.9.1 *Discussion*—A recommended complete wording has the form, “The normalized erosion resistance of (test material) relative to (reference material) based on (criterion of data analysis) is (numerical value).” **G40**

3.2.10 *normalized incubation resistance,  $N_o$ , n*—the nominal incubation period of a test material, divided by the nominal incubation period of a specified reference material similarly tested and similarly analyzed. (See also **normalized erosion resistance**.) **G40**

3.2.11 *terminal erosion rate, n—in cavitation or liquid impingement erosion*, the final steady-state erosion rate that is reached (or appears to be approached asymptotically) after the erosion rate has declined from its maximum value. (See also **terminal period** and **erosion rate-time pattern**.) **G40**

### 3.3 Definitions of Terms Specific to This Standard:

3.3.1 *cavitating jet, n*—a continuous liquid jet (usually submerged) in which cavitation is induced by the nozzle design or sometimes by a center body. See also *jet cavitation*.

3.3.2 *cavitation number,  $\sigma$* —a dimensionless number that measures the tendency for cavitation to occur in a flowing stream of liquid, and that, for the purpose of this test method, is defined by the following equation. All pressures are absolute.

$$\sigma = \frac{(p_d - p_v)}{\frac{1}{2} \rho V^2} \quad (1)$$

where:

$p_v$  = vapor pressure,  
 $p_d$  = static pressure in the downstream chamber,  
 $V$  = jet velocity, and  
 $\rho$  = liquid density.

3.3.2.1 For liquid flow through any orifice:

$$\frac{1}{2} \rho V^2 = p_u - p_d \quad (2)$$

where:

$p_u$  = upstream pressure.

3.3.2.2 For erosion testing by this test method, the cavitating flow in the nozzle is choked, so that the downstream pressure, as seen by the flow, is equal to the vapor pressure. The cavitation number thus reduces to:

$$\sigma = \frac{p_d - p_v}{p_u - p_v} \quad (3)$$

which for many liquids and at many temperatures can be approximated by:

$$\sigma = \frac{p_d}{p_u} \quad (4)$$

since

$$p_u \gg p_d \gg p_v \quad (5)$$

3.3.3 *jet cavitation, n*—the cavitation generated in the vortices which travel in sequence singly or in clouds in the shear layer around a submerged jet. It can be amplified by the nozzle design so that vortices form in the vena contracta region inside the nozzle.

3.3.4 *stand-off distance, n*—in this test method, the distance between the *inlet* edge of the nozzle and the target face of the specimen. It is thus defined because the location and shape of the inlet edge determine the location of the vena contracta and the initiation of cavitation.

3.3.5 *tangent erosion rate, n*—the slope of a straight line drawn through the origin and tangent to the *knee* of the cumulative erosion-time curve, when the shape of that curve has the characteristic S-shape pattern that permits this. In such cases, the tangent erosion rate also represents the maximum cumulative erosion rate exhibited during the test.

3.3.6 *vena contracta, n*—the smallest locally occurring diameter of the main flow of a fluid after it enters into a nozzle or orifice from a larger conduit or a reservoir. At this point the main or primary flow is detached from the solid boundaries, and vortices or recirculating secondary flow patterns are formed in the intervening space.

#### 4. Summary of Test Method

4.1 This test method produces a submerged cavitating jet which impinges upon a stationary specimen, also submerged, causing cavitation bubbles to collapse on that specimen and thereby to erode it. This test method generally utilizes a commercially available positive displacement pump fitted with a hydraulic accumulator to damp out pulsations. The pump delivers test liquid through a small sharp-entry cylindrical-bore nozzle, which discharges a jet of liquid into a chamber at a controlled pressure. Cavitation starts in the vena contracta region of the jet within the length of the nozzle; it is stabilized by the cylindrical bore and it emerges, appearing to the eye as a cloud which is visible around the submerged liquid jet. A button type specimen is placed in the path of the jet at a specified stand-off distance from the entry edge of the nozzle. Cavitation bubbles collapse on the specimen, thus causing erosion. Both the upstream and the downstream chamber pressures and the temperature of the discharging liquid must be controlled and monitored. The test specimen is weighed accurately before testing begins and again during periodic interruptions of the test, in order to obtain a history of mass loss versus time (which is not linear). Appropriate interpretation of the cumulative erosion-time curve derived from these measurements permits comparisons to be drawn between different materials, different test conditions, or between differ-

ent liquids. A typical test rig can be built using a 2.5-kW pump capable of producing 21-MPa pressure. The standard nozzle bore diameter is 0.4 mm, but this may be changed if required for specialized tests.

#### 5. Significance and Use

5.1 This test method may be used to estimate the relative resistances of materials to cavitation erosion, as may be encountered for instance in pumps, hydraulic turbines, valves, hydraulic dynamometers and couplings, bearings, diesel engine cylinder liners, ship propellers, hydrofoils, internal flow passages, and various components of fluid power systems or fuel systems of diesel engines. It can also be used to compare erosion produced by different liquids under the conditions simulated by the test. Its general applications are similar to those of Test Method G32.

5.2 In this test method cavitation is generated in a flowing system. Both the velocity of flow which causes the formation of cavities and the chamber pressure in which they collapse can be changed easily and independently, so it is possible to study the effects of various parameters separately. Cavitation conditions can be controlled easily and precisely. Furthermore, if tests are performed at constant cavitation number ( $\sigma$ ), it is possible, by suitably altering the pressures, to accelerate or slow down the testing process (see 11.2 and Fig. A2.2).

5.3 This test method with *standard conditions* should not be used to rank materials for applications where electrochemical corrosion or solid particle impingement plays a major role. However, it could be adapted to evaluate erosion-corrosion effects if the appropriate liquid and cavitation number, for the service conditions of interest, are used (see 11.1).

5.4 For metallic materials, this test method could also be used as a screening test for applications subjected to high-speed liquid drop impingement, if the use of Practice G73 is not feasible. However, this is not recommended for elastomeric coatings, composites, or other nonmetallic aerospace materials.

5.5 The mechanisms of cavitation erosion and liquid impingement erosion are not fully understood and may vary, depending on the detailed nature, scale, and intensity of the liquid/solid interactions. Erosion resistance may, therefore, arise from a mix of properties rather than a single property, and has not yet been successfully correlated with other independently measurable material properties. For this reason, the consistency of results between different test methods (for example, vibratory, rotating disk, or cavitating jet) or under different experimental conditions is not very good. Small differences between two materials are probably not significant, and their relative ranking could well be reversed in another test.

5.6 Because of the nonlinear nature of the erosion-time curve in cavitation erosion, the shape of that curve must be considered in making comparisons and drawing conclusions. Simply comparing the cumulative mass loss at the same cumulative test time for all materials will not give a reliable comparison.

6. Apparatus

6.1 General Arrangement:

6.1.1 Fig. 1 shows an arrangement of the test chamber. A cavitating jet supplied from a constant pressure source ( $p_u$ ) discharges, through a long-orifice nozzle (Fig. 2), into a chamber held at specified constant pressure ( $p_d$ ). A flat-ended cylindrical specimen (Fig. 3) is mounted coaxially with the nozzle so that the stand-off distance between the nozzle inlet edge and the specimen face can be set at any required value. A movable jet deflector (Fig. 1, Item 11) may be provided to protect the specimen while test conditions are being set up. Windows may be provided at both sides of the chamber so that the erosion process can be observed. Unless the complete test chamber assembly can withstand maximum operating pressures that could occur under any conceivable circumstances, a pressure relief valve must be fitted.

6.1.2 Manufacturing drawings of the apparatus giving pertinent dimensions are given in an Adjunct.<sup>3</sup> For special applications; for example, where the nature of the test specimen material is granular with granules comparable to the nozzle size, a larger apparatus is required. All linear dimensions must then be increased proportionately; for example, by a factor of two to five for rock or concrete specimens.

6.2 The long-orifice nozzle (Fig. 2) is simply a cylindrical bore hole of length equal to  $3.0 \pm 0.1$  bore diameters. It is important that the inlet edge is sharp and free from manufacturing defects and burrs. The nozzle must be made from a highly erosion- and corrosion-resistant alloy. The shape of the nozzle holder affects the nozzle performance so it is also specified in Fig. 2.

6.3 The specimen is held in place in a two-jaw collet. A line shall be scribed on the top of the holder so that it can be aligned with a corresponding line on the specimen to ensure that the specimen is fitted always in the same angular position. Similar provision shall be made so that the holder fits only one way into the chamber block.

6.4 The complete test circuit is shown in Fig. 4, and further described in Annex A1. The test chamber (12) can be used with either open or recirculating systems. The open system uses a tap water supply with the discharge running to waste, while in the closed system the test liquid is recirculated. (**Warning**—If tests with corrosive liquids are contemplated, all system components including the pump should be of stainless steel or other materials capable of handling such liquids.)

6.5 A pump capable of producing a pressure of 21 MPa and a flow of 4.5 L/min is required.

6.6 For measurement of upstream and chamber pressures, either standard test gages (0.25 % accuracy) or pressure transducers of at least equal precision and stability, having appropriate pressure ranges, shall be provided. It is strongly recommended that the low-pressure gage used for the downstream pressure measurement be protected by an appropriate pressure relief valve.

6.7 For measurement of the liquid temperature, a thermometer well or thermocouple shall be provided in the outlet pipe just downstream of the test chamber.

6.8 A suitable heater shall be provided in the system so that the desired test temperature can be maintained.

6.9 It is useful and makes testing easier if pressure regulators are fitted to control upstream and downstream pressures.

6.10 As the nozzle and regulating valve openings are small and solid particles must not reach the specimen, filters (40  $\mu\text{m}$  or finer) shall be fitted in both upstream and downstream lines. Alternatively a settling tank can be fitted on the downstream side.

6.11 If a recirculating system is used, a sump large enough to ensure adequate cooling shall be provided. A sump capacity of not less than 100 L is recommended; cooling is essential in such a system.

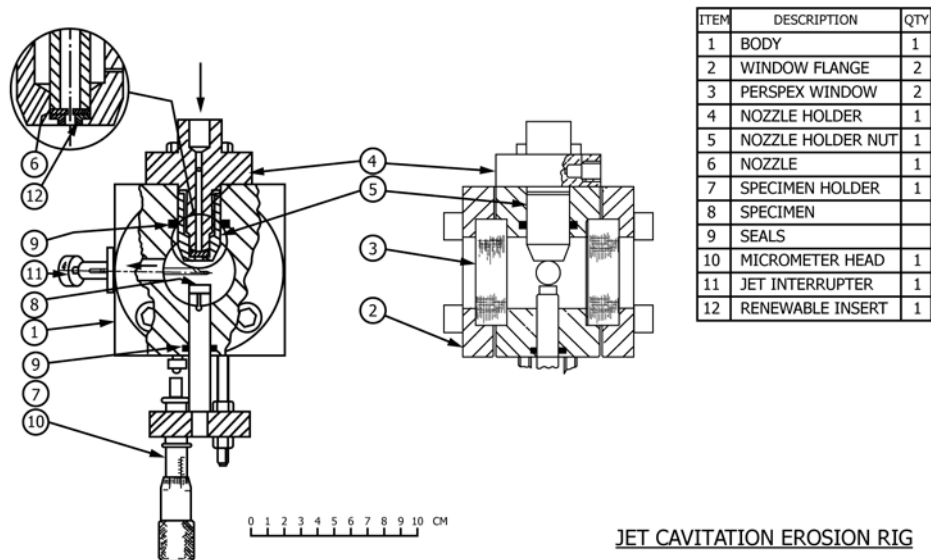

NOTE 1—Reprinted by permission of the University of Nottingham.

FIG. 1 Test Chamber Assembly

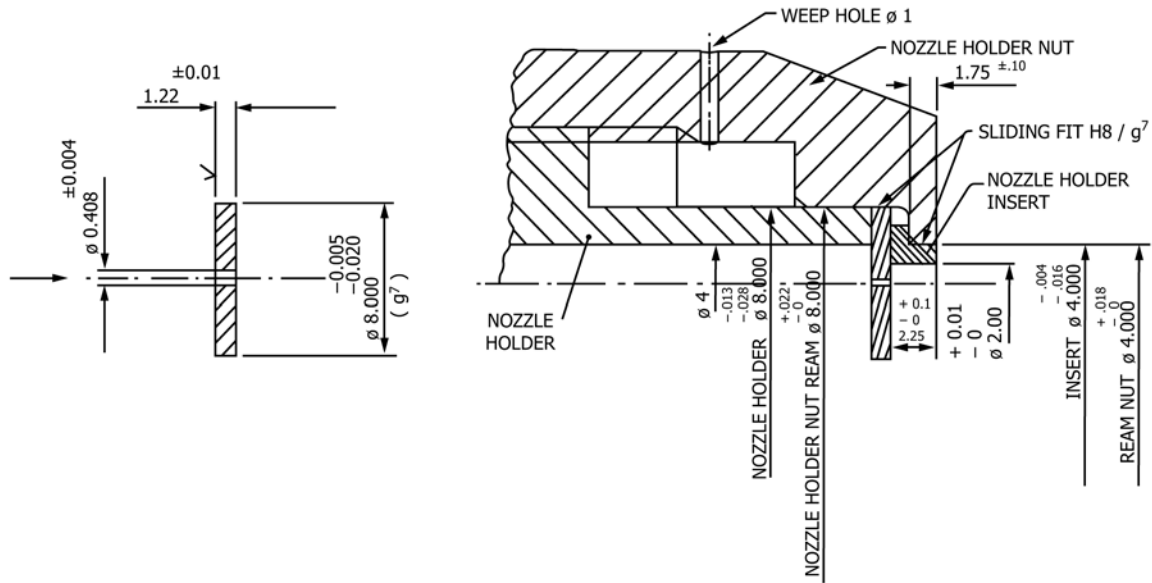

NOTE 1—Material is Nitronic 60.  
 NOTE 2—It is important that the inlet corner is sharp. It must not reflect light.  
 NOTE 3—Before drilling small hole, polish both sides with 1200 paper. Drill first, 0.35 and follow with, 0.40.  
 NOTE 4—All dimensions are in mm.

FIG. 2 Nozzle and Nozzle Holder

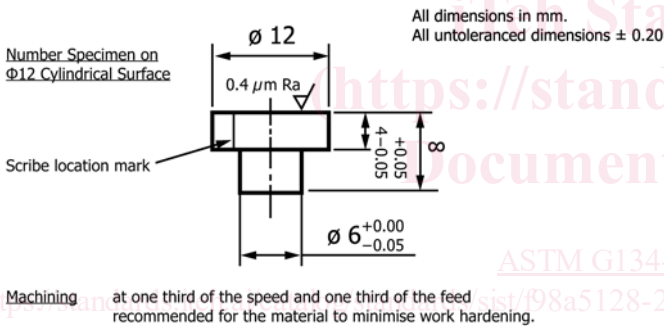

NOTE 1—See Section 8 for additional information.

FIG. 3 Test Specimen

6.12 A very useful addition to the facility is an automatic timer which switches the pump off after a preset test time has elapsed.

## 7. Precautions

7.1 **Caution**—When testing relatively weak or brittle materials, ensure that they will not be damaged by merely the stagnation pressure developed by the jet and that, therefore, the erosion is attributable solely to cavitation. This can be done most easily by a preliminary test during which cavitation is suppressed while the jet velocity is kept constant; this is achieved by increasing both the downstream pressure and the upstream pressure by the same amount. Sometimes it may be advisable to check on the margin of safety by increasing the upstream pressure (but not exceeding the safe pressure limits for the apparatus) in this preliminary test until damage to the specimen does occur.

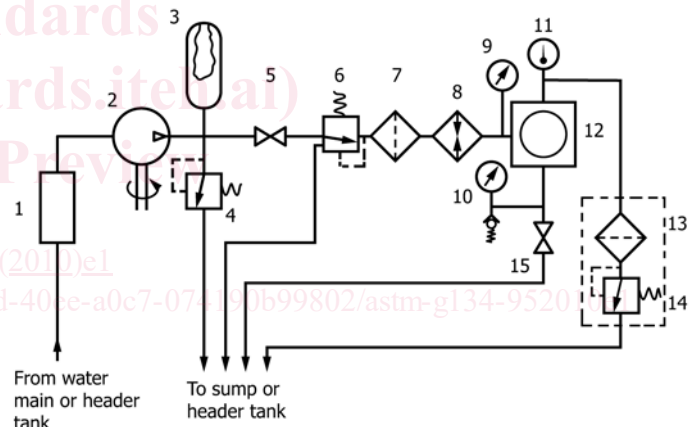

NOTE 1—Key:

- |  |  |
|--|--|
| 1. Pulsation damper                                    | 8. Heater  |
| 2. Pump  | 9. Upstream pressure gage 0 to 25 MPa                    |
| 3. Hydraulic accumulator pulsation damper              | 10. Downstream pressure gage with protector 0 to 0.6 MPa |
| 4. Pressure-relief valve                               | 11. Thermometer  |
| 5. On-Off valve  | 12. Test chamber   |
| 6. Pressure-regulating valve or by-pass throttle valve | 13. Downstream regulator                                 |
| 7. H.P. filter   | 14. Pressure regulator                                   |
|  | 15. Drain valve  |

NOTE 2—If closed system with header tank is used, cooling is essential.

FIG. 4 Test Circuit

7.2 **Caution**—This apparatus can generate high sound levels, so the use of ear protection may be necessary.

## 8. Test Specimen

8.1 The test specimen is shown in Fig. 3. The test surface shall be plane, and normal to the specimen axis within an indicator reading of 0.02 mm.

8.2 Unless otherwise required, the test surface shall be lightly machined, then optionally ground or polished to a maximum surface roughness of 0.4 μm (16 μin.), in such a way as to minimize surface damage or alteration. (For some materials, machining at one third the speed and one third the feed normally recommended has been found satisfactory.) While extremely fine finish is not required, there shall be no visible pits or scratch marks that would serve as sites for accelerated cavitation damage. For final finishing, 600-grit emery cloth may be used.

8.3 Some materials may require heat treatment to remove effects caused by machining and to ensure uniform hardness. The treatment must not alter the desired state of the material.

8.4 For materials available in sheet form, it is permissible to fix a disk of material by an appropriate adhesive to a suitably modified carrier. Ensure that the test material thickness is sufficient to accommodate erosion without weakening the specimen. A thickness of 3 mm would generally be sufficient.

8.5 A number of additional specimens may be required for setting up test conditions; for example, pressures, temperatures.

8.6 Ensure that a sufficient number of test specimens are prepared from the same stock.

9. Calibration

9.1 A pressure/flow test as described in A2.1, to determine its discharge coefficient, shall be carried out on a new nozzle and thereafter at regular intervals, initially after 40 h of use, to check that the nozzle has not deteriorated. If there develops any change in discharge coefficient greater than 1 %, take corrective action. An increase in the discharge coefficient indicates wear of the inlet edge; a decrease indicates blockage. Also examine the nozzle holder exit for erosion.

9.2 Perform a complete test on a standard reference material (see 12.9 and Table 1) at standard test conditions (see 10.1) from time to time to verify the consistency of performance of

the apparatus. Conduct this calibration at standard test conditions even if the apparatus is usually operated at optional test conditions.

9.3 As a brief check, a sample of previously tested material can be inserted for an interval of time appropriate to the material, say half an hour for steel. The result can then be compared with the previously obtained data.

10. Standard Test Conditions

10.1 If this test method is cited without additional test parameters, it shall be understood that the test conditions selected conform to the following:

10.1.1 The test liquid shall be tap water or reagent water conforming to Type IV of Specification D1193.

10.1.2 The water temperature at nozzle inlet shall be 35 ± 1°C.

10.1.3 Preliminary tests shall be carried out at two cavitation numbers on two different specimens, to enable assessment at various cavitation conditions and to determine appropriate testing times. These two values and the corresponding pressures are prescribed in Table 1.

10.1.4 The major tests shall be carried out at one constant cavitation number (selected on the basis of 10.1.3) so that cavitation conditions remain constant. One of the pressures must be specified and the other can be calculated from definition of cavitation number, σ (see 3.3.2). The value will depend on the materials tested and should be chosen so that the test durations are acceptable.

10.1.5 The tests shall be carried out at the stand-off distance at which maximum cumulative erosion rate occurs. This value of stand-off distance depends on cavitation number σ. As a guide for establishing this optimum stand-off distance, Fig. 5 may be used. The exact value for the apparatus used shall be determined experimentally; see A2.3. If the value of the cavitation number is to be changed, a new optimum stand-off distance must be established.

TABLE 1 Standard Test Conditions and Reference Materials

NOTE 1—Test liquid: Water (tap or deionized)  
 Test temperature: T = 35 (±1)°C  
 Corresponding vapor pressure: p<sub>v</sub> = 0.00563 MPa

NOTE 2—Upstream pressure (p<sub>u</sub>) and downstream pressure (p<sub>d</sub>) given in MPa absolute, for different cavitation numbers (σ) and reference materials.

NOTE 3—If two materials are to be used as references, nickel is to be tested at the lower pressure if the other material is aluminum, or at the higher pressure if the other material is steel.

Material	σ = 0.014		σ = 0.025	
	p <sub>u</sub>	p <sub>d</sub>	p <sub>u</sub>	p <sub>d</sub>
Soft aluminum 1100, UNS A91100, Specification B211. (Heat for 2 h at 400°C, air cool.)	12.5	0.18	12.5	0.32
Annealed wrought Nickel 200, UNS N02200, Specification B160. (See Note 3)	17.5	0.25	17.4	0.44
Austenitic stainless steel Type 316, UNS S31600, Specification A276, Hardness 150 to 175 HV.	17.5	0.25	17.4	0.44

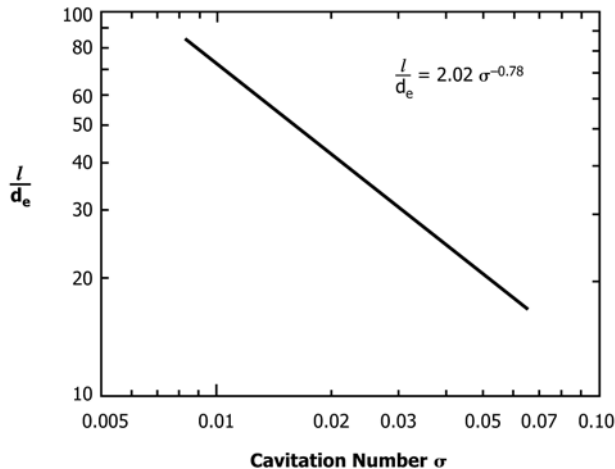

l = stand-off distance, d<sub>e</sub> = d√C<sub>d</sub>, C<sub>d</sub> = discharge coefficient, d = nozzle diameter

FIG. 5 Variation of Stand-Off Distance With Cavitation Number