



Designation: F519-08 Designation: F519 - 10

Standard Test Method for Mechanical Hydrogen Embrittlement Evaluation of Plating/ Coating Processes and Service Environments¹

This standard is issued under the fixed designation F519; the number immediately following the designation indicates the year of original adoption or, in the case of revision, the year of last revision. A number in parentheses indicates the year of last reapproval. A superscript epsilon (ϵ) indicates an editorial change since the last revision or reapproval.

This standard has been approved for use by agencies of the Department of Defense.

1. Scope

1.1 This test method describes mechanical test methods and defines acceptance criteria for coating and plating processes that can cause hydrogen embrittlement in steels. Subsequent exposure to chemicals encountered in service environments, such as fluids, cleaning treatments or maintenance chemicals that come in contact with the plated/coated or bare surface of the steel, can also be evaluated.

1.2 This test method is not intended to measure the relative susceptibility of different steels. The relative susceptibility of different materials to hydrogen embrittlement may be determined in accordance with Test Method F1459 and Test Method F1624.

1.3 This test method specifies the use of air melted AISI E4340 steel per SAE AMS-S-5000 (formerly MIL-S-5000) heat treated to 260 – 280 ksi (pounds per square inch x 1000) as the baseline. This combination of alloy and heat treat level has been used for many years and a large database has been accumulated in the aerospace industry on its specific response to exposure to a wide variety of maintenance chemicals, or electroplated coatings, or both. Components with ultimate strengths higher than 260 – 280 ksi may not be represented by the baseline. In such cases, the cognizant engineering authority shall determine the need for manufacturing specimens from the specific material and heat treat condition of the component. Deviations from the baseline shall be reported as required by section 12.1.2. The sensitivity to hydrogen embrittlement shall be demonstrated for each lot of specimens as specified in section 9.5.

1.4 Test procedures and acceptance requirements are specified for seven specimens of different sizes, geometries, and loading configurations.

1.5 *Pass/Fail Requirements*—For plating/coating processes, specimens must meet or exceed 200 h using a sustained load test (SLT) at the levels shown in Table 3.

1.5.1 The loading conditions and pass/fail requirements for service environments are specified in Annex A5.

1.5.2 If approved by the cognizant engineering authority, a quantitative, accelerated (≤ 24 h) incremental step-load (ISL) test as defined in Annex A3 may be used as an alternative to SLT.

1.6 This test method is divided into two parts. The first part gives general information concerning requirements for hydrogen embrittlement testing. The second is composed of annexes that give specific requirements for the various loading and specimen configurations covered by this test method (see section 9.1 for a list of types) and the details for testing service environments.

1.7 The values stated in the foot-pound-second (fps) system in inch-pound units are to be regarded as standard. The values given in parentheses are mathematical conversions to SI units that are provided for information only and are not considered standard.

1.8 *This standard does not purport to address all of the safety concerns, if any, associated with its use. It is the responsibility of the user of this standard to establish appropriate safety and health practices and determine the applicability of regulatory limitations prior to use.*

2. Referenced Documents

2.1 *ASTM Standards:*²

B374 [Terminology Relating to Electroplating](#)

B851 [Specification for Automated Controlled Shot Peening of Metallic Articles Prior to Nickel, Autocatalytic Nickel, or Chromium Plating, or as Final Finish](#)

¹ This test method is under the jurisdiction of ASTM Committee F07 on Aerospace and Aircraft and is the direct responsibility of Subcommittee F07.04 on Hydrogen Embrittlement.

Current edition approved May 1, 2008. Published July 2008. Originally approved in 1977. Last previous edition approved in 2006 as F519-06 ^{ϵ 2}. DOI: 10.1520/F0519-08. Current edition approved Dec. 1, 2010. Published January 2011. Originally approved in 1977. Last previous edition approved in 2008 as F519-08. DOI: 10.1520/F0519-10.

² For referenced ASTM standards, visit the ASTM website, www.astm.org, or contact ASTM Customer Service at service@astm.org. For *Annual Book of ASTM Standards* volume information, refer to the standard's Document Summary page on the ASTM website.

D1193 Specification for Reagent Water
 E4 Practices for Force Verification of Testing Machines
 E8 Test Methods for Tension Testing of Metallic Materials
 E18 Test Methods for Rockwell Hardness of Metallic Materials
 E29 Practice for Using Significant Digits in Test Data to Determine Conformance with Specifications
 E691 Practice for Conducting an Interlaboratory Study to Determine the Precision of a Test Method
 E709 Guide for Magnetic Particle Testing
 E1417 Practice for Liquid Penetrant Testing
 E1444 Practice for Magnetic Particle Testing
 E1823 Terminology Relating to Fatigue and Fracture Testing
 F1459 Test Method for Determination of the Susceptibility of Metallic Materials to Hydrogen Gas Embrittlement (HGE)
 F1624 Test Method for Measurement of Hydrogen Embrittlement Threshold in Steel by the Incremental Step Loading Technique
 F2078 Terminology Relating to Hydrogen Embrittlement Testing
 G5 Reference Test Method for Making Potentiostatic and Potentiodynamic Anodic Polarization Measurements
 G38 Practice for Making and Using C-Ring Stress-Corrosion Test Specimens
 2.2 *SAE AMS Standard:*³
 AMS 2430 (R) Shot Peening, Automatic
 AMS 2759/2 Heat Treatment of Low-Alloy Steel Parts Minimum Tensile Strength 220 ksi (1517 MPa) and Higher
 AMS 2759/11 Stress Relief of Steel Parts
 AMS 6360 Steel Tubing, Seamless 0.95Cr – 0.20Mo (0.28 – 0.33C) (SAE 4130) Normalized or Stress Relieved
 AMS-QQ-P-416 Plating, Cadmium (Electrodeposited)
 AMS-S-5000 Steel, Chrome-Nickel-Molybdenum (E4340) Bars and Reforging Stock
 2.3 *Military and Federal Standards and Commercial Item Descriptions:*⁴
 MIL-PRF-16173 Corrosion Preventive Compound, Solvent Cutback, Cold-Application
 Commercial Item Description (CID) A-A-55827 Chromium Trioxide, Technical

3. Terminology

3.1 *Definitions*—Definitions of terms used in this test method may be found in Terminology B374, Terminology E1823 and Terminology F2078.

3.2 *Acronyms and Abbreviations* :

AISI = American Iron and Steel Institute

a/W = notch depth-to-width ratio

d/D = ratio of minor to major diameters at the notch [ASTM F519-10](#)

ESH = Environmental, Safety and Health

fps = foot pound second

HRC = Rockwell Hardness Scale C

ID = inside diameter

ISL = incremental step load

kip = pounds load multiplied by 1000

ksi = pounds-force per square inch multiplied by 1000

K_t = stress concentration factor

LS = longitudinal short transverse

NFS = notched fracture strength

OD = outside diameter

psi = pounds-force per square inch

RMS = root mean square

SAE AMS = Society of Automotive Engineers Aerospace Material Specification

SCE = saturated calomel electrode

SLT = sustained load test

T.I.R. = total indicated runout

4. Summary of Test Methods

4.1 *Plating/coating Processes*—Unstressed test specimens are cleaned, plated/coated, and baked (if applicable) in accordance with the specification to which the process is to be qualified. Specimens are then maintained under a sustained load in air to

³ Available from Society of Automotive Engineers (SAE), 400 Commonwealth Dr., Warrendale, PA 15096-0001, <http://www.sae.org>.

⁴ Copies of these documents are available at <http://assist.daps.dla.mil/quicksearch/> or <http://assist.daps.dla.mil> or from the Standardization Document Order Desk, 700 Robins Ave., Building 4D, Philadelphia, PA 19111-5094.

measure the time to rupture/completion of the test period.

4.2 *Service Environments*—Specimens are tested in the service environment. The sequence of exposure to the environment and loading shall be as defined in Annex A5. If plated/coated test specimens are to be utilized for evaluating a service environment, then the plating/coating process must first be determined to be acceptable in accordance with section 4.1.

5. Significance and Use

5.1 *Plating/coating Processes*—This test method provides a means by which to detect possible hydrogen embrittlement of steel parts during manufacture by verifying strict controls during production operations such as surface preparation, pretreatments, and plating/coating. It is also intended to be used as a qualification test for new plating/coating processes and as a periodic inspection audit for the control of a plating/coating process.

5.2 *Service Environment*—This test method provides a means by which to detect possible hydrogen embrittlement of steel parts (plated/coated or bare) due to contact with chemicals during manufacturing, overhaul and service life. The details of testing in a service environment are found in Annex A5.

6. Apparatus

6.1 *Testing Machine*—Testing machines shall be within the guidelines of calibration, force range, resolution, and verification of Practices E4.

6.2 *Gripping Devices*—Various types of gripping devices may be used in either tension or bending to transmit the load applied by the testing machine or self-loading frame to the test specimen.

6.3 *Service Environment Testing*—For testing in service environments, an inert container and fixture arrangement that is suitably electrically isolated from the specimen or compensated to prevent galvanic coupling shall be used for testing in aqueous environments. The corrosion potential of the specimen may be controlled with a reference Saturated Calomel Electrode (SCE) or equivalent reference electrode such as with Ag/AgCl in accordance with Reference Test Method G5.

7. Materials and Reagents

7.1 Materials:

7.1.1 Air melted AISI E4340 per AMS-S-5000 (formerly MIL-S-5000).

7.1.2 Aluminum oxide (150 grit or finer), and 180-grit silicon-carbide paper.

7.1.3 Conditioned shot, in accordance with AMS 2430.

7.2 Reagents:

7.2.1 Corrosion preventive compound, meeting the requirements of MIL-PRF-16173, Grade 2.

7.2.2 Cadmium cyanide electroplating bath (SAE AMS-QQ-P-416, formerly Federal Specification QQ-P-416. (Table 2).

7.2.3 Maintenance chemicals, cleaners, paint strippers, and aqueous environments.

7.2.4 Chromic acid (CID A-A-55827, formerly Federal Specification O-C-303D).

7.2.5 Water (Specification D1193 Type IV).

8. Hazards

8.1 Environmental, Safety and Health (ESH):

8.1.1 Equipment, materials, solutions, and emissions (if applicable) shall be controlled, handled, used, and disposed in accordance with the applicable governing ESH regulations.

9. Test Specimens

9.1 Configuration—:

9.1.1 Dimensional drawings with tolerances are given for the two types of specimens in the following annexes:

9.1.1.1 Type 1—Notched Specimens

Type 1a: Notched, Round, Tension

Type 1a.1—Standard Size—per Fig. A1.1

Annex A1

Type 1a.2—Oversized—per Fig. A1.2

Annex A1

Type 1b: Notched, Round, Tension Self Loading Fixture—per Figs. A2.1-A2.5

Annex A2

Type 1c: Notched, Round, Bend Self Loading Fixture—per Fig. A2.6, Fig. A2.7

Annex A2

Type 1d: Notched, C-Ring, Bend Self Loading Fixture—per Fig. A2.8, Fig. A2.9

Annex A2

Type 1e: Notched, Square, Bend—per Fig. A3.1

Annex A3

9.1.1.2 Type 2—Smooth Specimens

Type 2a: O-Ring, Bend Self Loading Fixture—per Fig. A4.1, Fig. A4.2

Annex A4

9.1.2 The notched round tension, round bend and square bend specimens shall be loaded in the longitudinal grain direction, but the C-Ring and O-Ring can only be loaded normal to the longitudinal grain direction.

9.2 *Manufacture:*

9.2.1 Stress concentration factors (K_t) for each of the specimen types were calculated using Finite Element Analysis (FEA) and the dimensions in the drawings.

iTeh Standards
(<https://standards.itih.ai>)
Document Preview

[ASTM F519-10](#)

<https://standards.itih.ai/catalog/standards/sist/a427b527-2390-45b8-b616-d90ecc65f4c5/astm-f519-10>

NOTE 1—An ASTM Research Report documenting the analysis is in process and a reference number will be included in a future revision.

| Type | K_t | | |
|------|----------------------|---------|----------------------|
| | Minimum ^A | Nominal | Maximum ^A |
| 1a.1 | 3.16 | 3.30 | 3.48 |
| 1a.2 | 3.31 | 3.59 | 3.76 |
| 1b | 2.86 | 3.07 | 3.33 |
| 1c | 3.30 | 3.45 | 3.62 |
| 1d | 3.73 | 4.03 | 4.42 |
| 1e | 3.95 | 4.27 | 4.60 |
| 2a | NA | NA | NA |

^A Minimum and maximum K_t s calculated from worst case combinations of dimensional tolerances.

9.2.2 If the 60° notch angle does not permit plating/coating to the root of the notch, then an angle of 90° ± 1° shall be used only with prior approval of the cognizant engineering authority.

NOTE 2—The FEA determined that changing the notch angle from 60° to 90° had a negligible effect on the K_t . Therefore, no dimensional changes are required to compensate for this deviation. However, such deviation shall be reported as required in 12.1.2.

9.2.3 The baseline material/condition for test specimens is normalized and tempered, hot or cold drawn bar stock, air melted AISI E4340 steel per AMS-S-5000 (formerly MIL-S-5000) heat treated per AMS 2759/2 Class A to a tensile strength between 260 and 280 ksi (51 to 53 Rockwell C Hardness Scale (HRC)) as determined according to Test Methods E18. Rounding per Practice E29 permits an absolute hardness range of 50.6 to 53.4 HRC of the average of three measurements.

9.2.3.1 Other steels or final hardnesses may only be substituted if agreed upon by the cognizant engineering authority. Deviations from the baseline shall be reported as required in 12.1.2.

9.2.4 Rough machine blanks as required.

9.2.5 Heat treat as a finished part to a strength level of 260 to 280 ksi per AMS 2759/2 Class A as follows:

9.2.5.1 Austenitize at 1500 – 1550°F in a protective atmosphere and then quench in oil.

9.2.5.2 Double temper, 2 h each, at 425 – 490°F.

9.2.6 Verify heat treat response by pulling 4 specimens in accordance with Test Method E8 and Table 1.

9.2.7 Finish machine the reduced section and notch configuration.

9.2.7.1 The entire notch shall be ground to size.

9.2.7.2 Single-point machining of the notch is not permitted.

9.2.7.3 Burnishing of the notch is not permitted.

9.2.7.4 Shot peening/blasting/mechanical cleaning of the notch during specimen manufacturing is not permitted.

9.2.8 After grinding, all specimens shall receive a stress relief bake at 375 ± 25°F (190 ± 14°C) per AMS 2759/11 for 4–5 h. A suitable protection from discoloration due to surface oxidization shall be used.

9.2.9 Acid or cathodic electrolytic cleaning is prohibited.

9.2.10 Straightening after final heat treatment is prohibited.

9.3 *Storage:*

9.3.1 After stress relief baking, all specimens shall be protected during storage to prevent corrosion. A suitable means of protection is to coat the specimen with a corrosion preventive compound meeting the requirements of MIL-PRF-16173, Grade 2.

9.4 *Inspection:*

9.4.1 A lot shall consist of those specimens cut from the same heat of steel in the same orientation, heat treated together in the same furnace load, quenched and tempered together and subjected to the same manufacturing processes together.

9.4.2 All notched specimens in the lot shall be suitable for test purposes if the inspection results on samples from that lot conform to the requirements of Table 1 and section 9.5.

9.5 *Sensitivity Test:*

9.5.1 The sensitivity to hydrogen embrittlement shall be demonstrated for each lot of specimens by exposing six trial specimens to two different embrittling environments after manufacture and inspection in accordance with Section 9.

9.5.1.1 Three specimens shall be electroplated under the highly embrittling conditions produced in a bright cadmium cyanide bath by Treatment A (Table 2) and the remaining three specimens shall be electroplated under the less embrittling conditions of Treatment B (Table 2). An equivalent plating/coating or imposed potential may be used only with the approval of the cognizant engineering authority if its sensitivity is demonstrated to be equivalent to that found in Table 2.

9.5.2 Using the SLT method, each lot of specimen shall be of suitable sensitivity only if all three specimens plated by Treatment A fracture within 24 h and none of the three specimens plated by Treatment B fracture within 200 h after applying the sustained loads specified in Table 3 .

9.5.3 Using the ISL test method, each lot of specimens shall be of suitable sensitivity only if all three specimens plated by Treatment A initiate a crack at less than 50 % NFS and all of the three specimens plated by Treatment B fracture above 90% NFS identified in Table 3. The loading profile to be used with this standard is fifteen load increments of 5 % NFS sustained for one hour plus five increments of 5 % NFS for 2 h each or (15/5/1) + (5/5/2), which totals to a maximum of 24 hour loading profile for a maximum anticipated load of 100 % NFS.

9.6 *Certification:*

9.6.1 Each lot of specimens manufactured and sold shall be certified in writing to indicate that it meets the conditions found

TABLE 1 Lot Acceptance Criteria for Notched Specimens

| Type | Item | Sampling of Each Lot | Requirement/Method |
|------|---|----------------------|--|
| 1 | Tensile Strength | 4 each | Test Method E8. Tensile strength of each specimen must be within 10 ksi of the average. |
| 1 | Hardness ^A | 5 % | 51 to 53 HRC per Test Methods E18. Round the average of three readings per specimen per Practice E29. |
| 1 | Dimensions | 100 % | Meet tolerances of corresponding drawings. Notch dimension verified with shadow graphic projection at 50 to 100× or equivalent. |
| 1 | Notched Fracture Strength (NFS) | 10 ea | Test Method E8. NFS of each specimen must be within 10 ksi |
| 1c | Self-loading notched round specimen bend fixture, Fig. A2.7 | 10 ea | of the average. Alternate: The number of turns of the loading bolt, which is required to produce fracture in each specimen, must be within 5 % of the average. |
| 1d | Self-loading notched C-Ring bend fixture, Fig. A2.8 | 10 ea | Alternate: The change in diameter at fracture load for each specimen must be within 0.008 inches of the average. |

^A If the hardness requirements of any of the sampled specimens are not satisfied, only those specimens of the lot that are individually inspected for conformance to these requirements shall be used for testing.

TABLE 2 Electroplating Bath Compositions and Operating Conditions for Sensitivity Test

| Item | Treatment A | Treatment B |
|---|--|--|
| Bath composition: | Range | Optimum |
| Cadmium (as CdO) | 2.9 to 5.5 oz/gal (22 to 41 g/L) | 4.5 oz/gal (33.7 g/L) |
| Total Sodium cyanide (NaCN) | 12.0 to 16.0 oz/gal (89.9 to 120 g/L) | 14 oz/gal (104 g/L) |
| Ratio NaCN to CdO | 2.8/1 to 6.0/1 | 3.0/1 |
| pH | 12.0 or greater | 12.0 |
| Temperature | 70–90°F (21–32°C) | 75°F (24°C) |
| Sodium hydroxide (NaOH) ^A | 1.0 to 3.2 oz/gal (7.5 to 24.0 g/L) | 2.5 oz/gal (18.7 g/L) |
| Brightener such as ROHCO 20 X L or equivalent | Manufacturer's suggested range | None |
| Electroplating current | 10 A/ft ² (108 A/m ²) | 60 A/ft ² (645 A/m ²) |
| Electroplating time | 30 minutes | 6 minutes |
| Baking | | |
| Baking temperature | 375 ± 25°F (190 ± 14°C) | same as Treatment A |
| Baking time: Type 1 Specimen | Do Not Bake | 23 h |
| Baking time: Type 2a Specimen | 8 h | 23 h |
| Chromate Treatment ^B | Yes | same as Treatment A |

^A Addition of sodium hydroxide may not be required on solution makeup, since the addition of 1 oz/gal of cadmium oxide is equivalent to 0.6 oz/gal of free hydroxide.

^B After baking, the specimens shall be dipped into any appropriate chromate conversion coating solution for minimum time that will produce an adherent and continuous coating as described in AMS-QQ-P-416 Type II.

in this section, including the following information:

- 9.6.1.1 Manufacturer of specimen lot.
- 9.6.1.2 Steel supplier, heat number, and certificate for chemical composition and heat treatment response.
- 9.6.1.3 Heat treat process certification for specimen lot.

TABLE 3 Pass/Fail Loading Requirements of Test Specimens

| | |
|-------------------------|--|
| Type 1a, 1b, 1c, 1d, 1e | 75 % of the tensile or bend NFS (Table 1). |
| Type 2a | 92 % of the Test Methods E8, E4 ultimate strength, obtained by deflecting a 2.300-inch diameter O-Ring specimen with a 2.525-inch stressing bar. |

9.6.1.4 Test results for requirements in Table 1 and 9.6, including the corresponding average rupture load in units of X.XX kips (1 kip = 1000 pounds load).

10. Procedure

10.1 Plating/coating Processes:

10.1.1 *Number of Specimens*—A minimum of four specimens shall be used per test.

10.1.2 *Re-Use of Specimens*—Test specimens produced and tested per this test method shall only be used once. Stripping and reuse of specimens are prohibited.

10.1.3 *Plating/Coating Coverage*—~~The notch, including the root, shall be covered by plating/coating as determined by a visual inspection.~~ The entire specimen with the exception of the grip areas shall be covered by plating/coating as determined by a visual inspection.

10.1.4 *Masking of Grip Areas of Specimens*—The grip areas of the specimens may be masked to prevent plating/coating deposit when required to avoid interference with the test fixture. If the grip area is masked, this fact shall be reported.

10.1.5 *Masking To Provide Hydrogen Escape Path*—Non-porous plating/coatings such as nickel or bright cadmium can inhibit the outward diffusion of hydrogen. Therefore, when plating specimens with these types of plating/coatings it is necessary to leave a portion of the specimen unplated/coated so that the hydrogen can be baked out. The following guidelines are established for masking specimens to be plated/coated with hard, non-porous coatings:

10.1.5.1 *All notched Types (1a.1, 1a.2, 1b, 1c, 1d, and 1e)*—The entire notch and 0.5 inch on either side of the notch shall be plated/coated.

10.1.5.2 *Type 2a Smooth Ring*—Only the edges may be masked. The entire ID and OD shall be plated/coated.

10.1.6 *Dimensions for Stress Calculations*—The dimensions of the bare metal specimen shall be used in stress calculations.

10.1.7 *SLT Method*—:

10.1.7.1 *Load*—Sustained load specimens shall be loaded in accordance with Table 3.

10.1.7.2 *Time*—Sustained loads shall be maintained for a minimum of 200 h. Actual fracture times may be electronically monitored with a relay switch system.

10.1.8 The alternate, ISL accelerated test (≤ 24 h) as described in Annex A3 of this document and as further defined in Test Method F1624 may be used only if specified by the cognizant engineering authority.

10.2 *Service Environments:*

10.2.1 The testing protocol (number, load, and time) shall be as specified in Annex A5.

11. Interpretation of Results

11.1 *No Fracture*—For the SLT method, a plating/coating process shall be considered non-embrittling if none of the plated/coated specimens fracture within 200 h after loading as specified in Table 3. Self-loading specimen Types (1b, 1c, 1d and 2a) may need to be examined using magnetic particle per Practice E1444 or liquid penetrant per Practice E1417 to determine if a crack initiated but did not propagate due to load relaxation.

11.2 *One of Four Fracture*—If only one of a minimum of four specimens fractures within the 200-h sustained load exposure time, the remaining three specimens may be step loaded every 2 h in 5 % increments to 90 % of the NFS after completion of the 200-h sustained load. If the three remaining specimens all sustain 90 % NFS for 2 h, the plating/coating process shall be considered non-embrittling.

11.3 *Two or More Fracture*—If two or more specimens fracture within the sustained load exposure time, the plating/coating process shall be considered embrittling.

11.4 *Replacement Testing*—Replacement testing shall only be conducted after the root cause of any failure has been determined to be anomalous.

11.4.1 *Root Cause Determination*—A failure may be ruled anomalous if it is determined that an error was made in the plating/coating process of the specimens or if a metallurgical examination of the fractured specimen indicates some defect in the manufacture of the specimen.

11.4.1.1 Pre-existing specimen defects such as cracks, grinding burns, or nonmetallic inclusions can be considered a basis for invalidation of test results and replacement testing.

11.4.1.2 Fracture at any location other than the notch invalidates the test and is a basis for replacement testing for all notched specimens (that is, all types except 2a).

11.4.2 *Number of Specimens*—A replacement test shall use four specimens. If any specimen fractures during the replacement test, the plating/coating process shall be considered embrittling. If the failure is determined to be anomalous, retesting per 11.4 may be repeated.

12. Report

12.1 A test report shall be produced upon completion of testing that bears the minimum information specified in 12.1.1 through 12.1.5.

12.1.1 A lot acceptance and sensitivity certification report.

NOTE 3—The lot acceptance and sensitivity report may be provided by the specimen manufacturer.

12.1.2 The type and number of specimens tested including deviations from baseline geometry, material, temper, K_t , or masking practices.

12.1.3 A description of the plating/coating process and test environment (concentration, temperature, and so forth) if other than ambient air.

12.1.4 The sustained or threshold load, or percent of NFS or notch bend strength of unplated specimens, or displacement as appropriate for the type of specimen tested.

12.1.5 The time under load in the test environments.

13. Precision and Bias

13.1 *Precision*—The sensitivity test requirement in section 9.5 and the acceptance and rejection criteria in Section 11 are the judgments for precision, and may vary with the precision on applied stress and test specimen geometry.

13.2 *Bias*—Random lot-to-lot bias in the properties of specimens related to raw material or specimen manufacture may exist.

14. Keywords

14.1 cleaner; coating; delayed failure; fluids; hydrogen embrittlement; maintenance chemicals; plating/coating; steel; stress cracking; threshold

iTeh Standards
(<https://standards.iteh.ai>)
Document Preview

[ASTM F519-10](#)

<https://standards.iteh.ai/catalog/standards/sist/a427b527-2390-45b8-b616-d90ecc65f4c5/astm-f519-10>

ANNEXES

(Mandatory Information)

A1. SPECIAL REQUIREMENTS FOR THE TESTING OF NOTCHED ROUND TENSION SPECIMENS

A1.1 *Type 1a*—The notched round tension specimen is given in two sizes. If the specimen geometry is not called out, the Type 1a.1, standard notched round specimen under load control, shall be used.

A1.1.1 *Type 1a.1 Standard*—The dimensions for the standard sized specimen for the sustained load test (SLT) are shown in Fig. A1.1. The test machine shall have a minimum load capacity of 10 kips to measure the NFS in accordance with Table 1. Correspondingly, a test machine with a minimum load capacity of 7.5 kips is required to maintain a sustained load of 75 % of the NFS in accordance with Table 3.

A1.1.2 *Type 1a.2*—The dimensions for the oversized specimen for SLT are shown in Fig. A1.2. The test machine must have a minimum capacity of 16 kips to measure the NFS in accordance with Table 1. Correspondingly, a minimum 12-kip test machine is required to maintain a sustained load of 75 % of the NFS in accordance with Table 3.

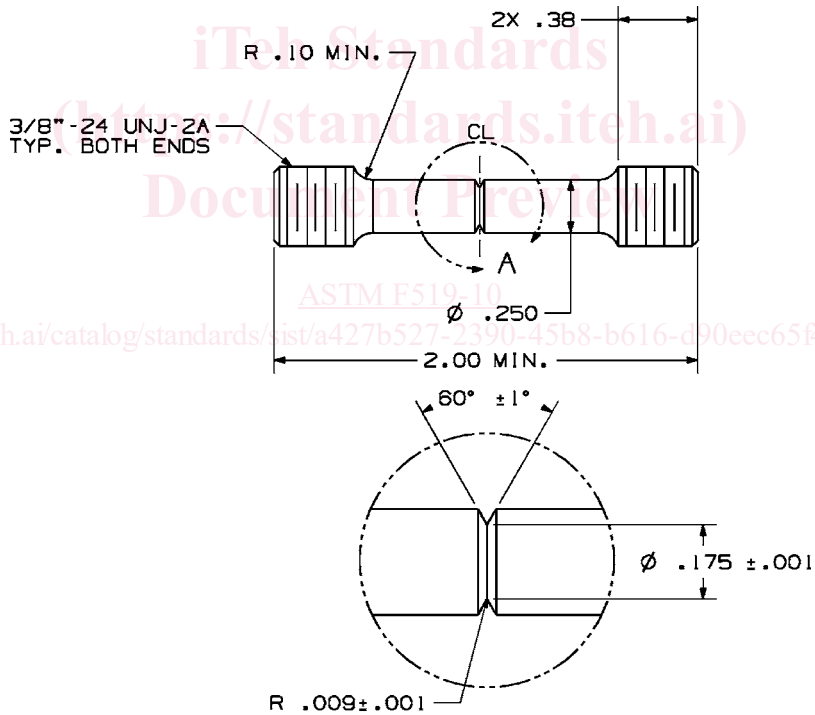

DETAIL A

Tolerances unless otherwise specified:

- X.X ± 0.1
- X.XX ± 0.03
- X.XXX ± 0.005

NOTE 1—Specimen preparation must comply with section 9.2.

NOTE 2—Surface finish of notch shall be 32 RMS or better, all other surfaces shall be 63 RMS or better.

NOTE 3—Configuration of the ends of the specimen is optional so long as any external threaded ends have the minor diameter greater than 0.25 inch.

NOTE 4—Root radii, reduced section, and notch root radius must be concentric with centerline of specimen within 0.002 T.I.R. (total indicated runout).

FIG. A1.1 Dimensional Requirements for the Type 1a.1 Specimen

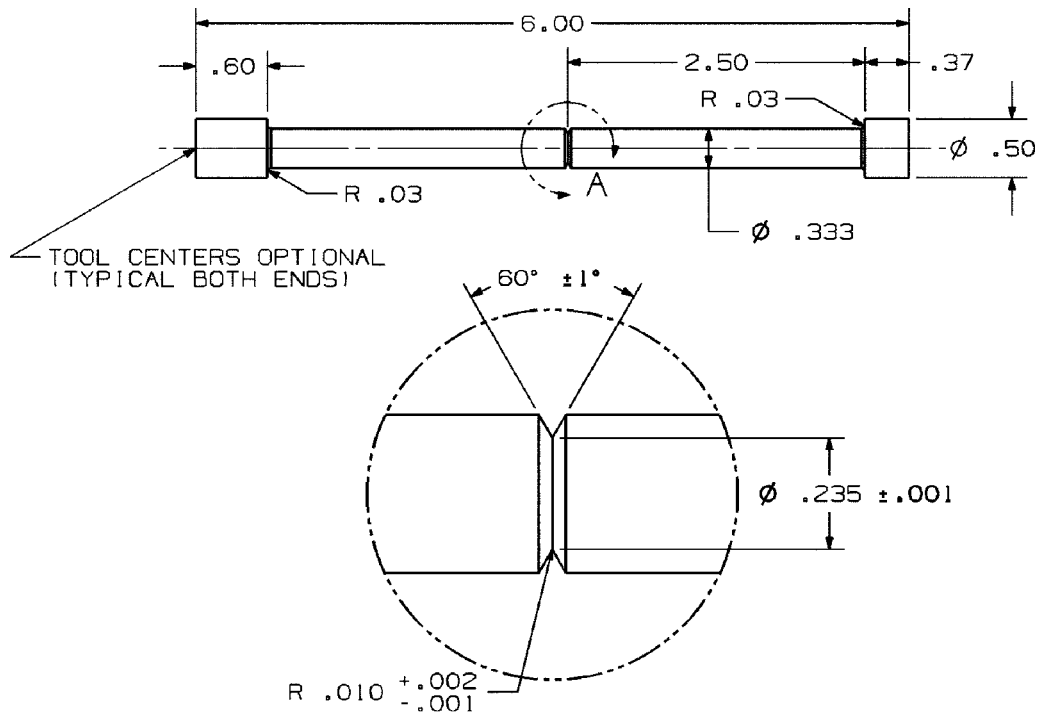

DETAIL A
Tolerances unless otherwise specified:
X.X ± 0.1
X.XX ± 0.05
X.XXX ± 0.007

- NOTE 1—Specimen preparation must comply with section 9.2.
NOTE 2—Surface finish of notch shall be 32 RMS or better, all other surfaces shall be 63 RMS or better.
NOTE 3—Configuration of the ends of the specimen is optional so long as any external threaded ends have the minor diameter greater than 0.35 inch.
NOTE 4—Root radii, reduced section, and notch root radius must be concentric with centerline of specimen within 0.002 T.I.R.

FIG. A1.2 Dimensional Requirements for the Type 1a.2 Specimen

A2. SPECIAL REQUIREMENTS FOR THE TESTING OF NOTCHED SPECIMENS IN SELF-LOADING FIXTURE

A2.1 *Type 1b—Notched Tension Specimen*—Type 1b is a sub-sized specimen where the ratio of minor to major diameters at the notch ($d/D = 0.0895/0.188$). The specimen is loaded under a constant displacement and requires a special sustained loading device for loading to 75 % of the NFS. The capacity of the testing machine for determination of the NFS in accordance with Table 1 must exceed 2.5 kips. Consideration should also be given to Test Methods E8 - 04, Note 5, Figure 8 concerning the use of subsize specimens.

A2.1.1 The method of spring-loading notched round specimens in tension uses a pre-calibrated ring as detailed in Figs. A2.1-A2.5. The ring manufacturer calibrates each ring by determining the change in diameter of the ring when subjected to a load equivalent to that required to stress a test specimen to 75 % NFS.

A2.1.2 Mechanisms used to load a test specimen in a stressed ring must be able to hold the test specimen at a stress level of 90 % of the maximum load applied to the specimen. A method that allows loading and locking test specimens at stress levels as high as 75 % NFS is described as follows.

A2.1.3 Insert the test specimen in a calibrated ring. Fit the end of the specimen extending through the ring with a stainless steel retaining collar and insert it into the jaws of a hydraulic loading device. As the load is applied, the collar is swaged to the shaft of the specimen. No torsional loads shall be introduced during loading. The change in ring diameter after removal from the hydraulic loading device indicates the actual stress level obtained (test load) and this must be at least 90 % of the change in ring diameter produced during initial loading. If the specimen has not failed by the end of the test period, the measured ring diameter must be within 0.001 in. of that measured after initiating the test.