



Designation: ~~F1505-07~~ Designation: F1505 - 10

## Standard Specification for Insulated and Insulating Hand Tools<sup>1</sup>

This standard is issued under the fixed designation F1505; the number immediately following the designation indicates the year of original adoption or, in the case of revision, the year of last revision. A number in parentheses indicates the year of last reapproval. A superscript epsilon ( $\epsilon$ ) indicates an editorial change since the last revision or reapproval.

### 1. Scope\*

1.1 This specification covers the testing of insulated and insulating hand tools used for working on, or in close proximity to, energized electrical apparatus or conductors operating at maximum voltage of 1000 V ac or 1500 V dc.

1.2 The specific use ~~and maintenance~~ of these tools are beyond the scope of this specification.

1.3 The values stated in SI units are to be regarded as the standard. The inch-pound units given in parentheses are for information only.

1.4 The following precautionary caveat pertains to the test method portion only, Section 7, of this specification: *This standard does not purport to address all of the safety concerns, if any, associated with its use. It is the responsibility of the user of this standard to establish appropriate safety and health practices and determine the applicability of regulatory limitations prior to use.*

1.5 This specification does not purport to address all of the safety problems associated with the use of tools on, or in close proximity to, energized electrical apparatus.

### 2. Referenced Documents

#### 2.1 ASTM Standards:<sup>2</sup>

D149 Test Method for Dielectric Breakdown Voltage and Dielectric Strength of Solid Electrical Insulating Materials at Commercial Power Frequencies

D618 Practice for Conditioning Plastics for Testing

D5025 Specification for Laboratory Burner Used for Small-Scale Burning Tests on Plastic Materials

#### 2.2 ASME/ANSI Standards:

~~ASME B107 Series on Hand Tools and Accessories~~ ASME/ANSI Standards:<sup>3</sup>

ASME B18.3-2002 Socket Cap, Shoulder, Set Screws, Hex and Spline Keys

#### 2.3 IEC Standard:<sup>4</sup>

IEC 60900:2004 Live Working – Hand tools for use up to 1000 V ac and 1500 V dc

#### 2.4 ISO Standards:<sup>5</sup>

ISO 1174-1:1996 Assembly tools for screws and nuts—Driving Squares—Part 1: Driving squares for hand socket tools

ISO 5744:2004 Pliers and nippers—Methods of test

### 3. Terminology

#### 3.1 Definitions:

3.1.1 *insulated hand tools, n*—those covered with insulating material in order to protect the user from electric shock and to minimize the risk of short circuits between parts at different potentials.

3.1.2 *insulating hand tools, n*—those made predominantly of insulating material, except for metal inserts at the working head or active part or used for reinforcement but with no exposed metal parts. In either case, to protect the user from electric shocks, as well as, to prevent short-circuits between exposed parts at different potentials.

#### 3.2 Definitions of Terms Specific to This Standard:

3.2.1 *acceptance test, n*—a contractual test to prove to the customer that the device meets certain conditions of its specification.

<sup>1</sup> This specification is under the jurisdiction of ASTM Committee F18 on Electrical Protective Equipment for Workers and is the direct responsibility of Subcommittee F18.35 on Tools & Equipment.

Current edition approved Feb. 15, 2007. Published April 2007. Originally approved in 1994. Last previous edition approved in 2001 as F1505-01. DOI: 10.1520/F1505-07. Current edition approved Dec. 1, 2010. Published January 2011. Originally approved in 1994. Last previous edition approved in 2007 as F1505-07. DOI: 10.1520/F1505-10.

<sup>2</sup> For referenced ASTM standards, visit the ASTM website, [www.astm.org](http://www.astm.org), or contact ASTM Customer Service at [service@astm.org](mailto:service@astm.org). For *Annual Book of ASTM Standards* volume information, refer to the standard's Document Summary page on the ASTM website.

<sup>3</sup> Available from American Society of Mechanical Engineers (ASME), ASME International Headquarters, Three Park Ave., New York, NY 10016-5990, <http://www.asme.org>.

<sup>4</sup> Available from Institute of Electrical and Electronics Engineers, Inc. (IEEE), 445 Hoes Ln., P.O. Box 1331, Piscataway, NJ 08854-1331, <http://www.ieee.org>.

<sup>5</sup> Available from International Organization for Standardization (ISO), 1 rue de Varembe, Case postale 56, CH-1211, Geneva 20, Switzerland, <http://www.iso.ch>.

\*A Summary of Changes section appears at the end of this standard.

3.2.2 *formation of lots or batches, n*—the product is assembled into identifiable lots, sub-lots, batches, or in such other manner as may be prescribed. Each lot or batch, as far as practicable, consists of units of product of a single type, grade, class, size, and composition, manufactured under essentially the same conditions and essentially the same time.

3.2.3 *routine test, n*—a test to which each individual device is subjected during or after manufacture to ascertain whether it complies with certain criteria.

3.2.4 *sampling test, n*—a test on a number of devices taken at random from a batch.

3.2.5 *type test, n*—a test of one or more devices made to a certain design to show that the design meets certain specifications.

#### 4. Performance Requirements

4.1 Insulated and insulating tools shall be designed and manufactured in such a way that they do not constitute a danger for the user or the installation if they are used properly.

4.2 The mechanical specifications for insulated and insulating hand tools having the same function shall comply with the corresponding ANSI or ISO standards. The mechanical performance of the working parts shall be maintained even after the application of any insulating layer(s). The insulation material shall be such that it will adequately withstand the electrical, mechanical, and thermal stresses to which it may be exposed during normal use. Insulating hand tools specially designed for live working in an environment of live parts at different potentials (boxes with electrical equipment, live working on underground cables, etc.), that generally are used to hold or move live conductors or to cut wires of small section, must have adequate mechanical properties to avoid the risk of breaking and the possible corresponding electrical consequences. These tools shall be checked for compliance with 7.8.

4.3 All insulating material shall be flame resistant in accordance with 7.7.

4.4 The insulating coating may consist of one or more layers. If two or more layers are utilized, contrasting colors shall be employed.

4.5 The design and construction of the handles shall provide a secure handhold and prevent unintentional slipping.

4.6 The tool shall have an operating temperature range from  $-20$  to  $+70^{\circ}\text{C}$ .

4.7 The insulating material shall adhere securely to the conductive parts of the tool and any outer layer of the material over the temperature range from  $-20$  to  $+70^{\circ}\text{C}$ .

4.8 Tools intended for use at extremely low temperatures ( $-40^{\circ}\text{C}$ ) shall be designated “Category C” and shall be designed for this purpose.

4.9 Double-ended tools such as box wrenches, keys for hexagonal socket screws, double ended socket wrenches, double-head open-end wrenches, etc., are not allowed for insulated tools but are allowed for insulating tools.

4.10 *Tools Capable of Being Assembled:*

4.10.1 *Retaining Devices for Tools Capable of Being Assembled*—Tools capable of being assembled shall have suitable retaining devices to prevent unintentional separation of the assembly. The retaining forces shall be tested in accordance with 7.9.

4.10.2 *Insulation Design for Tools Capable of Being Assembled*—In the case of connecting parts of tools capable of being assembled, the insulation shall be applied in such a manner that if any part becomes detached during use, no conductive part, which may still be live, can be inadvertently touched or cause a disruptive charge.

4.10.3 *Tools Capable of Being Assembled with Square Drives*—Tools capable of being assembled with square drives shall have square drives and square sockets in accordance with ISO 1174-1 (for separating forces, see 7.9.1). To ensure compatibility of insulation between different manufacturers, these tools shall be designated with overlapping elements described in Fig. 1. Their dimensions and tolerances shall be in accordance with Table 1.

4.10.4 *Interchangeability of Components Made by Different Manufacturers*—Tools capable of being assembled and designed to be interchangeable between different manufacturers shall be specifically marked in accordance with 5.6.5. There are considerable difficulties in developing a unified standard for the mechanical joining systems for components and tools for different manufacturers. For safety reasons, only mechanically locked retaining systems shall be used for these kind of tools. Manufacturers shall include the following information in the instructions for use: To ensure that the complete assembly of insulated tool components from different manufacturers will withstand separating forces that are expected during the intended use, prior to the use of any assembly the use shall ensure, by pulling by hand in a separating direction, that the retaining devices of all used elements are working efficiently and no component gets separated.

#### 5. Additional Requirements

5.1 *Screwdrivers and Wrenches*—The following uninsulated areas on the working head are permissible (see Fig. 2):

5.1.1 *Screwdrivers* for slotted head screws, 15-mm ( $\frac{9}{16}$ -in.) maximum length,

5.1.2 *Other Types of Screwdrivers*, 18-mm ( $\frac{3}{4}$ -in.) maximum length, and

5.1.3 *Box Wrenches, Socket Wrenches, and T-Wrenches*—The working surfaces that contact the fastener.

5.1.4 *Engineer’s Wrenches*—The working surface.

NOTE 1—At the request of the customer, the uninsulated area may be extended to the working head.

5.1.5 *Bit Screwdrivers*—Bit screwdrivers are regarded as tools capable of being assembled. They shall meet the relevant requirements. The outer diameter of the insulation may exceed the dimensions of 5.2.

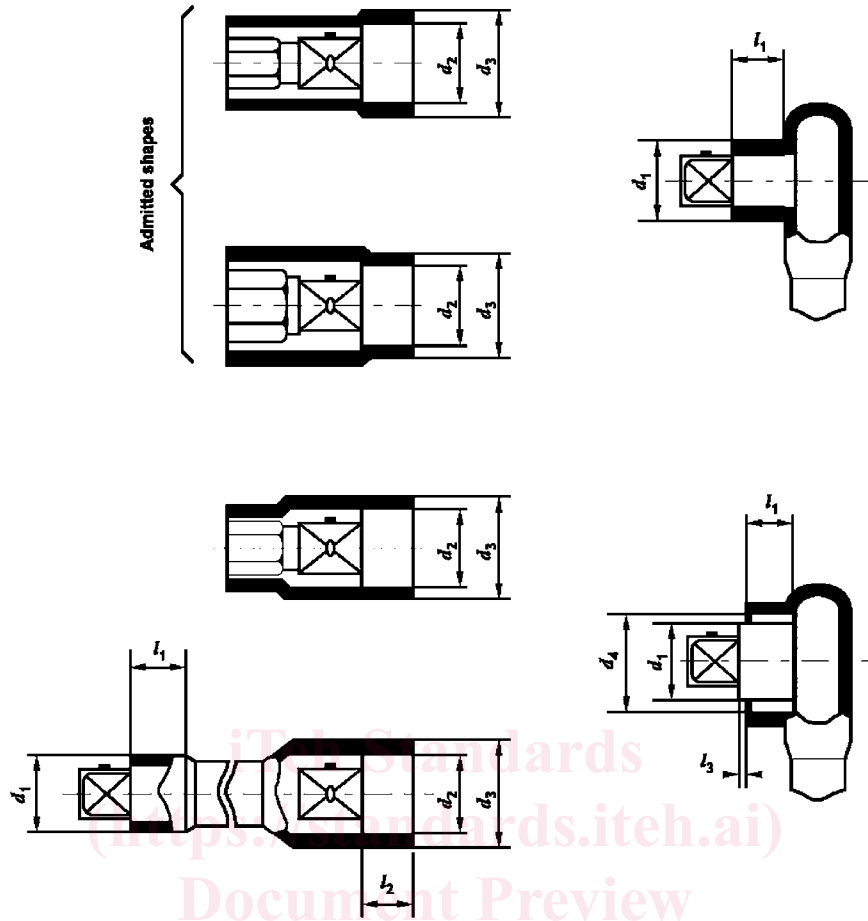

NOTE 1—Dimensions in millimetres

FIG. 1 Description of the Insulating Overlapping Element and Different Assembly Configurations for Tools Capable of Being Assembled with Square Drives (see 4.10.3)

TABLE 1 Dimensions and Tolerances of the Insulating Overlapping Element<sup>A</sup>

NOTE—Dimensions in millimetres.

Nominal size	$l_1$ min	$l_2$	$l_3$	$d_1$	$d_2$	$d_3$	$d_4$
		+2 0	+0.05 -0.05	0 -1.5	+1.5 0	0 -1.5	+1.5 0
6.3	19	16	2	12.5	13	18	19
10	19	16	2	17.5	18	23	24
12.5	19	16	2	21.5	22	27	28
20	19	16	2	32	33	38	39

<sup>A</sup> $l_1, l_2, l_3, d_1, d_2, d_3,$  and  $d_4$  are described in Fig. 1

5.1.6 *Screwdrivers with Screw Retaining Devices*—If a screwdriver has a screw retaining device, the screwdriver itself shall meet the requirements of this standard. The outer diameter of the retaining device may exceed the dimensions of 5.2. The retaining device shall be made from insulating material.

5.2 The blade insulation of screwdrivers shall be bonded to the handle. The outer diameter of the insulation, over a length of 30 mm ( $1\frac{3}{16}$  in.), in Area C of Fig. 2, shall not exceed the width of the blade at the tip by more than 2 mm ( $\frac{1}{16}$  in.). This area may be parallel or tapered towards the tip.

5.3 *Pliers, Strippers, Cable Cutting Tools, Cable Scissors:*

5.3.1 The handle insulation shall have a guard so that the hand is prevented from slipping towards the uncovered metal parts of the head (see Fig. 3(a) as an example). The height of the guard shall be sufficient to resist slippage of the fingers towards the conductive part during work. For pliers, the minimum dimensions of the guard shall be 10 mm ( $\frac{3}{8}$  in.) on the left and the right side of the pliers positioned on a flat surface, 5 mm ( $\frac{3}{16}$  in.) on the upper and lower part of the pliers positioned on a flat surface (see Fig. 3(a)).

5.3.2 The minimum insulated distance between the inner edge of the guard and the non-insulated part shall be 12 mm ( $\frac{1}{2}$  in.).

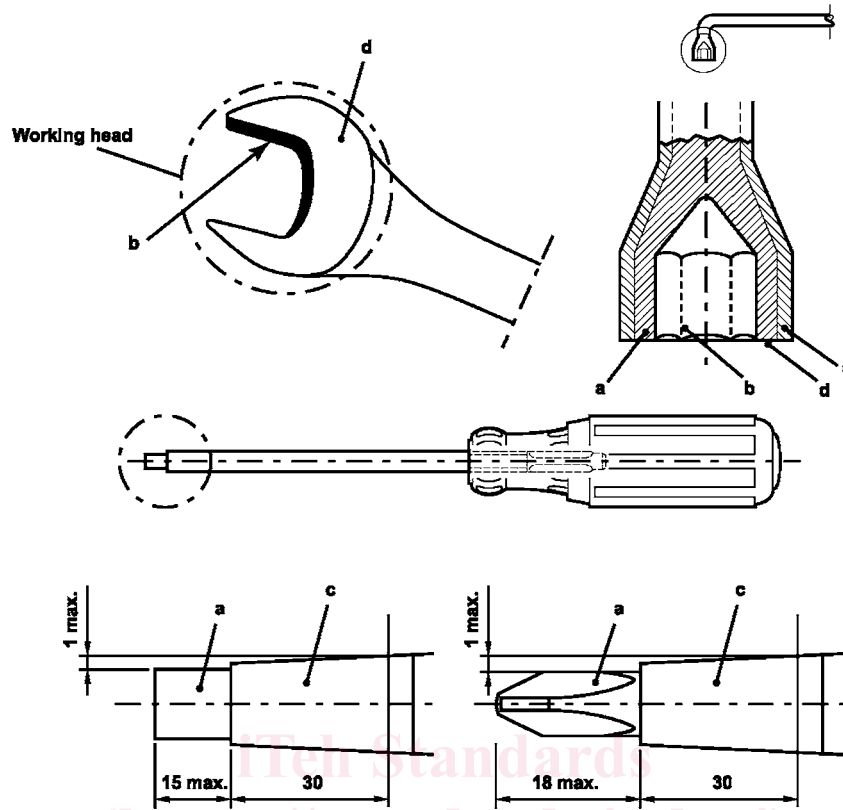

NOTE 1—Dimensions in millimetres.

NOTE 2—a = conductive part,  
b = working part,  
c = insulation, and  
d = contact part.

FIG. 2 Illustrations of Insulation of Typical Tools—Examples (see 5.1 and 5.2)

(see Fig. 3(a)). The insulating material shall extend as far as possible towards the working end of the tool.

5.3.3 In the case of a slip joint and an adjustable joint plier, a guard of 5 mm ( $\frac{3}{16}$  in.) minimum shall be provided for the inner part of the handles (see Fig. 4).

5.3.4 In the case of “micro tools” (that is, pliers and nippers for electronics) the dimensions of the guard shall be at least 5 mm on the left and right side of the pliers held on a flat surface and 3 mm on the upper part and the lower part of the pliers held on a flat surface. The minimum insulated distance between the inner edge of the guard and the non-insulated part shall extend as far as possible towards the working head (see Fig. 5).

5.3.5 If the handles of the tools exceed the length of 400 mm (16 in.), a guard is not required.

5.4 *Knives*—The minimum length of the insulated handle shall be 100 mm (4 in.). The handle shall have a guard on the side (see Fig. 3(b)) toward the blade to prevent the slipping of the hand onto the conductive blade. The minimum height of the guard shall be 5 mm ( $\frac{3}{16}$  in.). The minimum insulated distance between the inner edge of the guard and the non-insulated part shall be 12 mm ( $\frac{1}{2}$  in.) (see Fig. 3(b), letter b). The length of the uninsulated part of the knife blade shall not be longer than 65 mm ( $2\frac{1}{2}$ -in.) (see Fig. 3(b), letter c).

5.5 *Tweezers* (see Fig. 6):

5.5.1 The total length ( $l$ ) shall be 130-mm (5-in.) minimum and 200-mm (8-in.) maximum. The length of the handle ( $g$ ) shall be 80-mm (3-in.) minimum.

5.5.2 Both handles of the tweezers shall have a guard towards the working head. The guard shall not be movable. Its height  $h$  and width  $b$  shall be sufficient (5 mm ( $\frac{3}{16}$  in.) minimum, to prevent any slipping of the fingers during the work towards the uninsulated working head  $u$ . On both handles, the insulated part between the guard and the working head  $e$  shall be 12-mm ( $\frac{1}{2}$ -in.) minimum and 35-mm ( $1\frac{3}{8}$ -in.) maximum.

5.5.3 In the case of tweezers with a metallic working head, the metallic part shall have a minimum hardness of 35 HCR (Rockwell Hardness – C Scale) at least from the working head to the handles.

5.5.4 The uninsulated length  $u$  of the working head shall not exceed a length of 20 mm ( $\frac{3}{4}$  in.).

5.5.5 Insulating tweezers shall not have exposed conductive parts.

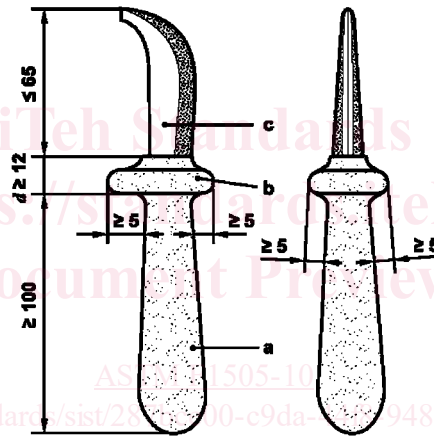
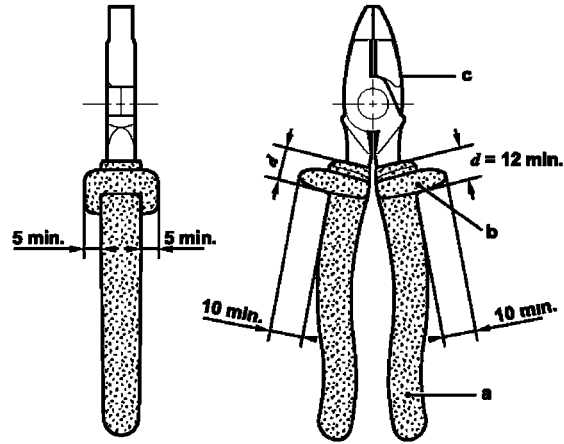

(a) Insulation of Pliers  
(b) Insulation of Knives

NOTE 1—Dimensions in millimetres.

NOTE 2—a = insulated handle or leg,

b = guard,

c = working head (not insulated), and

d = distance between the inner edge of the guard and the non-insulated part.

**FIG. 3 (a and b) Illustrations of Insulation of Pliers and Knives**  
(see 5.3.1, 5.3.2 and 5.4)

5.6 *Marking*—Each tool or tool component, or both, shall be marked permanently and legibly with the following information:

5.6.1 On the insulating material layer or on the metal conductive part include the following information:

5.6.1.1 Manufacturer's name or trademark,

5.6.1.2 Type or product reference.

5.6.2 On the insulating material layer include the following (see Fig. 7):

5.6.2.1 The double triangle symbol,

5.6.2.2 1000 V (the electrical working limit for alternating current), and

5.6.2.3 Year of manufacture (at least the last two digits of the year).

5.6.2.4 For tools designed for use at extremely low temperatures ( $-40^{\circ}\text{C}$ ), include letter "C".

5.6.2.5 The number of the relevant ASTM standard in the vicinity of the symbol with the year of publication (ASTM F1505-07).

Where there is a lack of space on the product itself, it is permissible to limit this marking to the number of the standard. In such

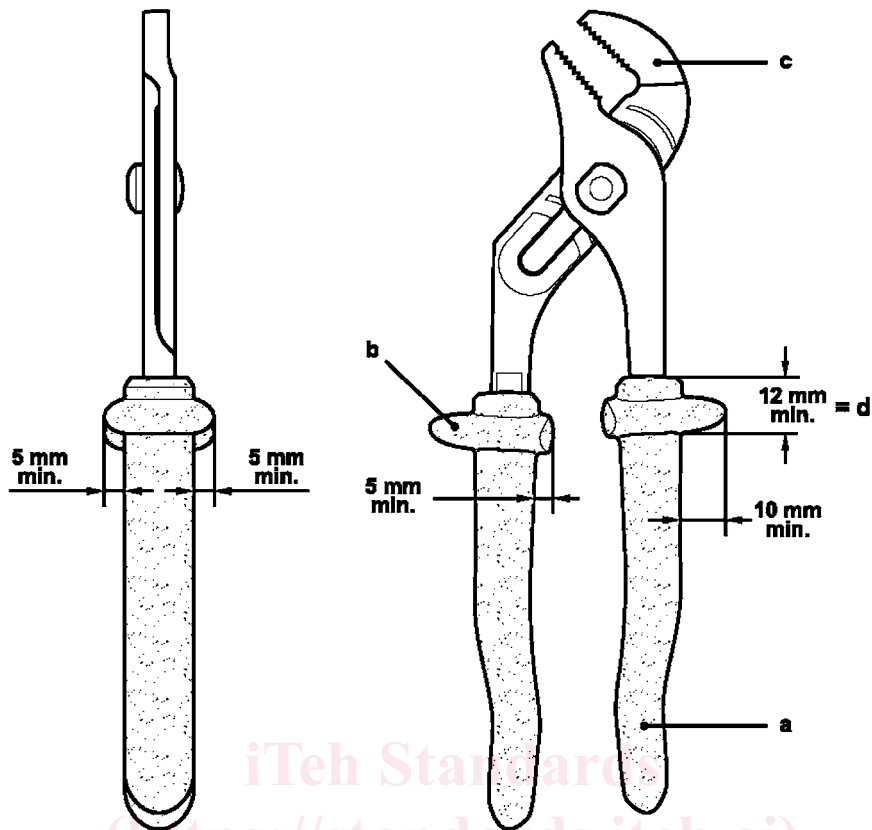

NOTE 1—Dimensions in millimetres

FIG. 4 Example for Insulation of the Handles of Multiple-Position, Adjustable and Slip-Joint Pliers (see 5.3.3)

case, the complete marking, including the year of publication shall appear on the smallest unit container in which the product is packaged.

5.6.3 The double triangle symbol shall be at least 3 mm ( $\frac{1}{8}$  in.) high. The letters and the figures shall be at least 2 mm ( $\frac{1}{16}$  in.) high (see Fig. 8).

5.6.4 The voltage markings described in 5.6.2 shall be the only voltage shown on the tool.

NOTE 2—The indication of a test voltage may lead to the erroneous assumption that the tool is suitable for work at that voltage.

5.6.5 The symbol for tools capable of being assembled and designed to be interchangeable between different manufacturers—the marking symbol and the dimensions are given in Fig. 9. The dimension  $H$  shall be greater than or equal to 5 mm.

5.6.6 Additional markings where specified by the customer.

5.7 *Instructions for Use*—In the case of tools that require assembly or adjustment, the proper method shall be stated in the instructions for use. Other instructions, such as verification before use and test methods should be given by the manufacturer, distributor, or user (see Appendix X4).—In the case of tools that require assembly or adjustment, the proper method shall be stated in the instructions for use. See Section 12.

## 6. Significance and Use

6.1 The performance and durability of the tools covered in this specification are not covered beyond those referenced in the applicable ASME, ANSI, or ISO standards.

6.2 The technical requirements of this specification either meet or exceed IEC 60900:2004 at the time of issue.

## 7. Type Tests

7.1 *General Test Specification* —The following tests shall be utilized to check compliance with the requirements outlined in Sections 4 and 5:

7.1.1 Perform the test procedures in 7.2-7.10 on each specimen sample in the sequence listed.

7.1.2 Perform the type tests on at least three samples of the same batch.

7.1.3 If there is any change in the design or manufacture of the tool since the last type test, repeat the type test.

7.1.4 Should a sample fail any part of the type tests, repeat the type tests on at least six additional samples of the same batch. Should any one sample then fail in any part of the repeated type test, the whole test is to be regarded as having failed.

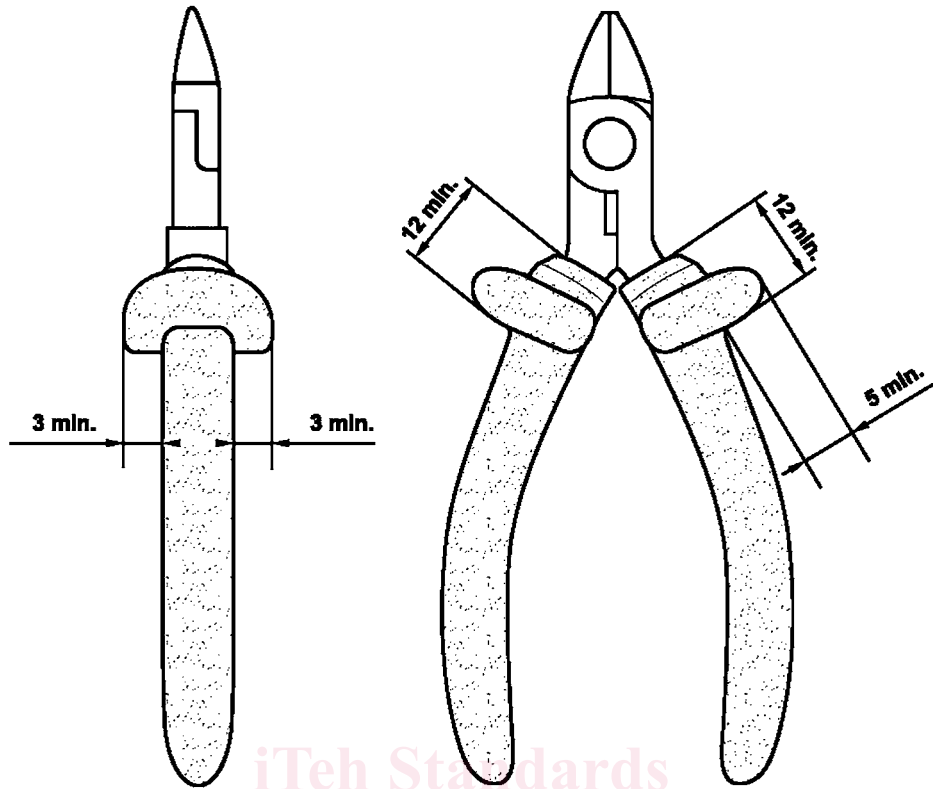

NOTE 1—Dimensions in millimetres

FIG. 5 Illustration of Insulation of Pliers and Nippers for Electronics (see 5.3.4)

7.1.5 Unless stated in the specification, perform the test after a minimum storage time of 16 h under IEC climatic conditions;  $23 \pm 5^\circ\text{C}$ , relative humidity 45 to 75 %.

7.1.6 Unless otherwise stated, deviations of 5 % from any test values required are permissible.

7.1.7 All tools that have failed the test shall be either destroyed or rendered unsuitable for use in live working. This also applies to any other tools from the batch unless the test is nondestructive. In this case, all tools shall be tested.

7.2 *Visual and Dimensional Check:* [standards/sist/287bce00-c9da-44f8-9486-a0643d470b53/astm-f1505-10](https://standards.sist/287bce00-c9da-44f8-9486-a0643d470b53/astm-f1505-10)

7.2.1 *Visual*—The tool and insulation shall be visually checked and shall be determined to be free from external defects. The marking shall be checked for legibility and completeness in accordance with 5.6.

7.2.2 *Dimensional*—Check the dimensions in accordance with Section 5.

7.3 *Impact Test:*

7.3.1 Perform the test in accordance with one of the two alternatives shown in Fig. 10 and Fig. 11. The hardness of the hammer shall be at least 20 HRC.

7.3.2 Select at least three points of the insulating material or insulating layer as testing points, these being points that could be damaged when the tool drops on a flat surface.

7.3.3 The test is passed if the insulating material shows no breaks, exfoliation, or cracks penetrating the insulating layer of the insulated tool, or are likely to reduce the solidity of the insulating tool.

7.3.4 *Ambient Temperature Test:*

7.3.4.1 Test the tool at the ambient temperature ( $23 \pm 5^\circ\text{C}$ ) of the test room.

7.3.4.2 Determine the fall height  $H$  as a function of its weight,  $P$ , so that the energy,  $W$ , of impact on the tool to be tested shall be equal to that of this tool falling from a height of 2 m onto a hard surface:

$$H = (W) / (P) = (2 \times F) / (P) \quad (1)$$

where:

$H$  = fall height of the hammer, m,

$F$  = weight of the tool tested, N, and

$P$  = weight of the hammer, N.

7.3.5 *Low-Temperature Test:*

7.3.5.1 Condition the tool by placement in a cooling chamber for 2 h at  $-25 \pm 3^\circ\text{C}$ .

7.3.5.2 The impact test shall take place within 2 min after removal from the cooling chamber. The ambient temperature shall be  $23 \pm 5^\circ\text{C}$ . The impact test shall be carried out according to 7.3.4.2.

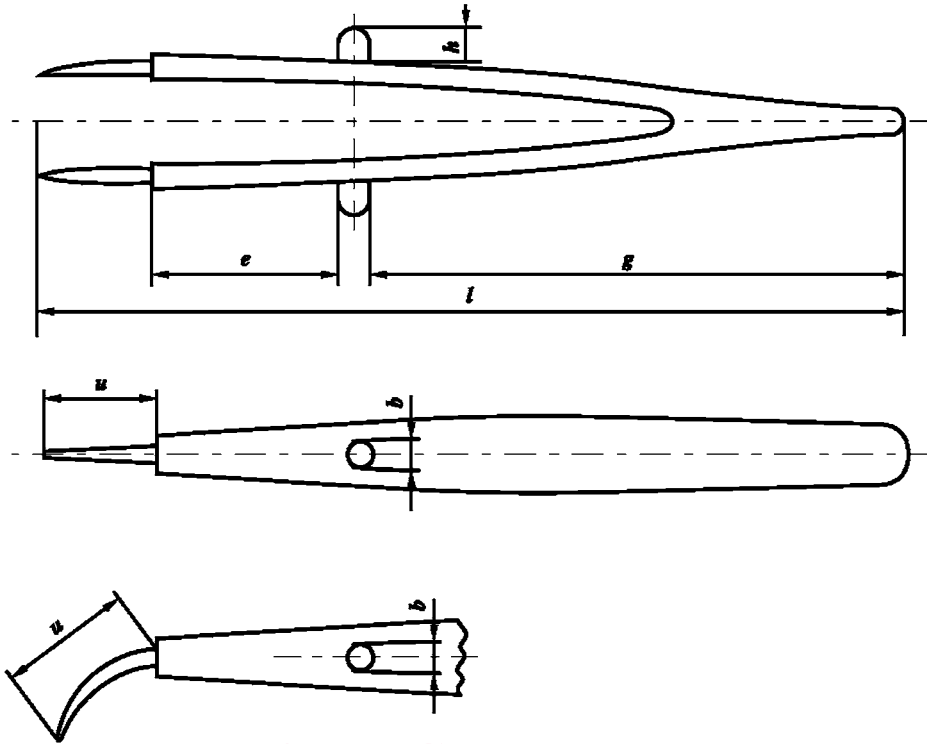

l = total length of the tweezers  
 g = length of the handle (grip)  
 b = width of the guard  
 h = height of the guard  
 e = insulated part of the handle between the guard and the working head  
 u = un-insulated part of the working head

FIG. 6 Example for Insulation of the Handles of Tweezers (see 5.5)



1000 V 07:47 "C"  
 ASTM F1505-07

NOTE 1—The specific markings and the order of the markings may vary depending on the product.

FIG. 7 Example of Markings on Insulating Materials, Consisting of (see 5.6.2): The double triangle symbol, the voltage rating for the tool, an example of a manufacturer's date code (YR:WK), the low temperature (−40°C) symbol, and the relevant ASTM standard

7.3.6 Extreme Low Temperature Test:

7.3.6.1 The tool shall be conditioned by placement in a cooling chamber for 2 h at −40°C ± 3°C.

7.3.6.2 The impact test shall take place within 2 min after removal from the cooling chamber. The ambient temperature shall be 23 ± 5°C.

7.3.6.3 Determine the fall height *H* as a function of its weight, *P*, so that the energy, *W*, of the impact on the tool to be tested shall be equal to that of the tool falling from a height of 0.6 m onto a hard surface.

$$H = (W)/(P) = (0.6 \times F)/(P) \tag{2}$$

where:

- H* = fall height of the hammer, m,
- F* = weight of the tool tested, N, and
- P* = weight of the hammer, N.

7.4 Dielectric Test Conditioning Before Testing—Condition the tools by total immersion in a bath of tap water at room temperature (23 ± 5°C) for a period of 24 ± 0.5 h.



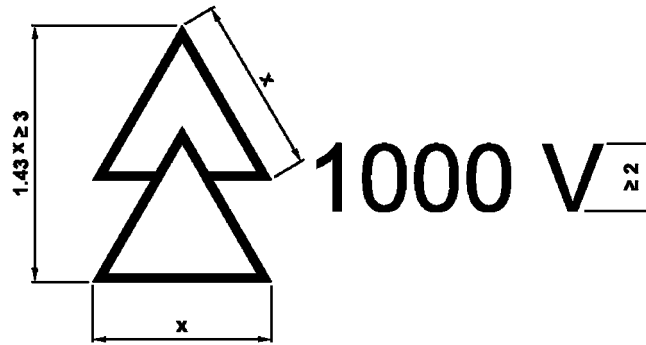

NOTE 1—Dimensions in millimetres.

NOTE 2—For the symbol, the exact ratio of the height of the figure to the base of the triangle is 1.43. For the purpose of convenience, this ratio can be between the values of 1.4 and 1.5.

**FIG. 8 Suitable for Live Working Symbol: Double Triangle with Voltage Indication (see 5.6.3)**

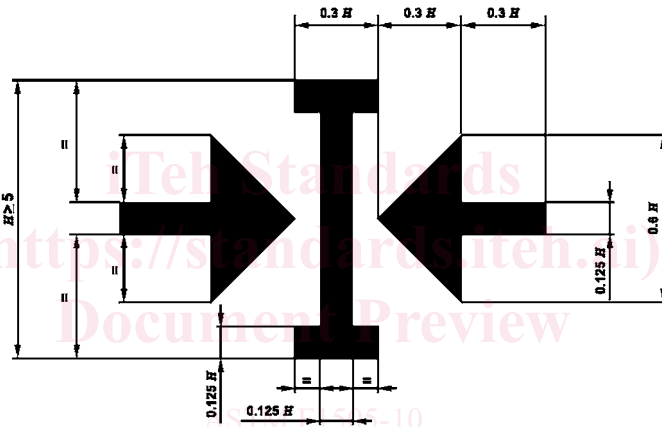

NOTE 1—Dimensions in millimetres.

**FIG. 9 Marking Symbol for Tools Capable of Being Assembled and Designed to be Interchangeable Between Different Manufacturers (see 5.6.5)**

7.4.1 In the case of tools capable of being field assembled, the water immersion shall be replaced by a storage at a relative humidity between 91 % and 95 % at a temperature of  $23 \pm 5^\circ\text{C}$  for 48 h. Tools shall not be assembled prior to conditioning.

NOTE 3—This humidity may be obtained by storage in a closed chamber which contains a saturated solution of sodium sulfate decahydrate  $\text{Na}_2\text{SO}_4 \cdot 10\text{H}_2\text{O}$  (Glauber's salt) having a large exposed surface.

7.4.2 After this conditioning, wipe the tools dry and submit to the dielectric tests:

7.4.3 *Insulated Tools*—Immerse the sample tool with its insulated part in a bath of tap water to a level of  $24 \pm 2$  mm ( $1 \pm \frac{1}{16}$  in.) from the nearest non-insulated part. The conductive part shall be above water level (see Fig. 12).

7.4.3.1 Test pliers and similar tools in such a position that the gap “d” between the two inner sides of the insulated handles is 2 to 3 mm ( $\frac{1}{16}$  to  $\frac{1}{8}$  in.), or the minimum possible by the tools construction, but not less than 2 mm ( $\frac{1}{16}$  in.) (see Fig. 12).

7.4.3.2 For tools capable of being field assembled, replace the water bath with a bath of 3 mm ( $\frac{1}{8}$  in.) diameter nickel stainless steel balls measured with normal industrial tolerances.

7.4.3.3 Continuously apply a voltage of 10 kV (rms) at commercial power frequencies for 3 min and measure the leakage current. This current shall be less than 1 mA for 200 mm (8 in.) of coated tool. This corresponds to a maximum value of the leakage current of:  $I = 5L$

where:

$I$  = leakage current rounded to the upper value, mA, and

$L$  = coated developed length in m (rounded to the lower value in centimeters).

NOTE 4—Appendix X1 gives examples of calculations of the developed length of coating and the limits of acceptable leakage current.

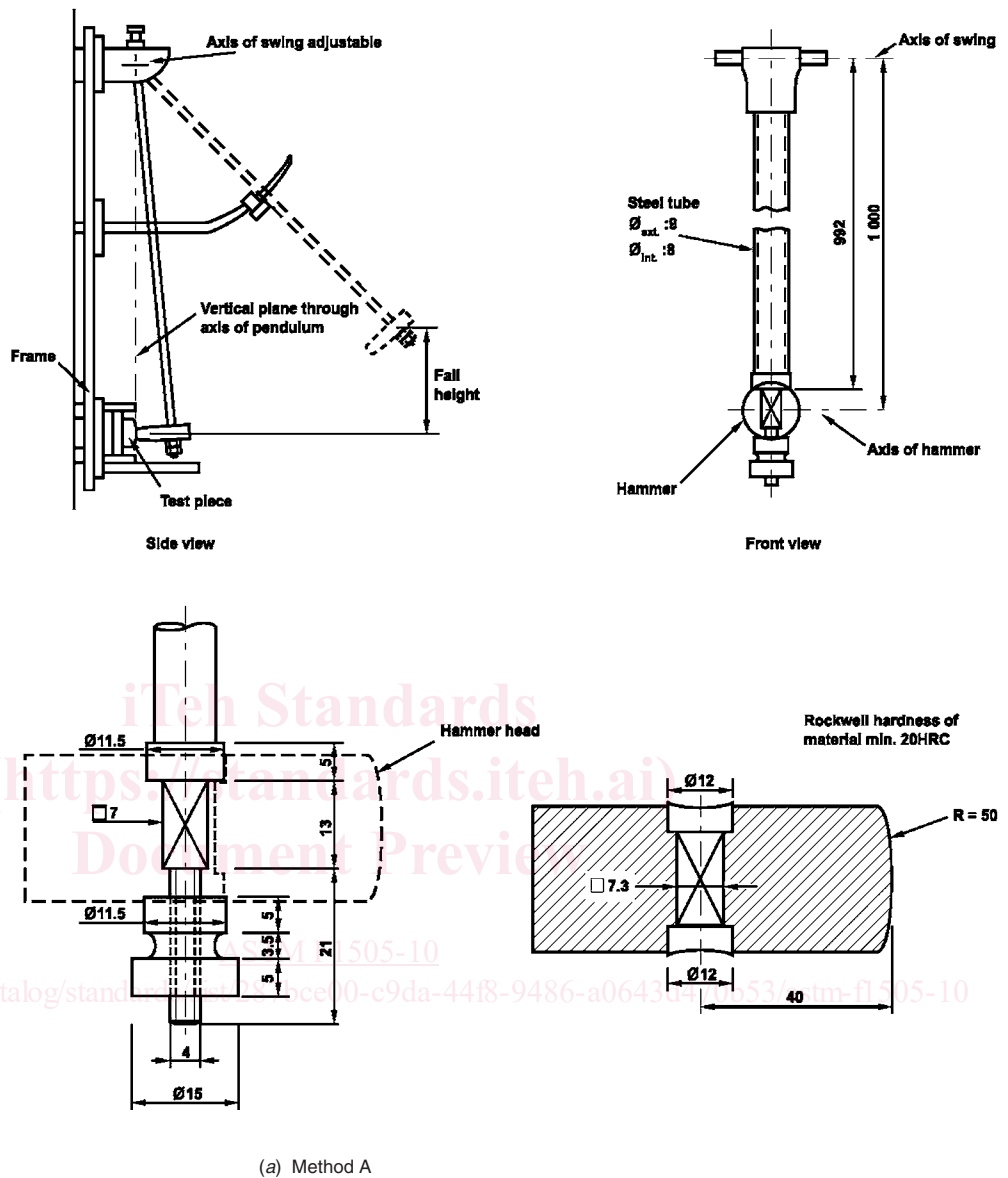

NOTE 1—Dimensions in millimetres.  
**FIG. 10 Example of Test Arrangements for the Low-Temperature Impact Test (see 7.3.1)**

7.4.3.4 Test tools capable of being field assembled in all possible variations. Test tools with holding devices on both end positions, if applicable. The test is considered passed if no electrical puncture, sparkover, or flashover occurs during the test period, and the limits of the leakage current are not exceeded.

7.4.3.5 *Dielectric Tests of Tools Capable of Being Assembled with Square Drives (see 4.10.3)*—In case of tools capable of being assembled with square drives, the tools can be tested in separate parts, if the parts are assembled with dummies described in Fig. 13. The dimensions and tolerances of the dummies shall be in accordance with Table 2. Dummy part 1 shall be assembled with female tool ends and dummy part 2 with male tool ends. On all single parts tested with dummies, the dielectric testing on the complete assembly is not required. The test shall be considered successful if no electrical puncture, sparkover or flashover occurs during the test period, and if the limits of leakage current are not exceeded.

7.4.4 *Insulating Tools—Dielectric Test Between the Working Head and the Handle (or Handles):*

7.4.4.1 Tools having a metallic working head shall be tested in accordance with 7.4.3.

7.4.4.2 *Tools Having No Exposed Metal Parts*—The purpose of this test is to check the dielectric quality of the material used for the handles. Electrodes (see Fig. 14) of conductive tape, foil, or conductive paint 5-mm ( $\frac{3}{16}$ -in.) wide are placed on the surface of the handles at  $24 \pm 2$ -mm ( $1\frac{5}{16} \pm \frac{1}{16}$ -in.) spacing.