



## Standard Test Method for Predicting Heat Buildup in PVC Building Products<sup>1</sup>

This standard is issued under the fixed designation D4803; the number immediately following the designation indicates the year of original adoption or, in the case of revision, the year of last revision. A number in parentheses indicates the year of last reapproval. A superscript epsilon ( $\epsilon$ ) indicates an editorial change since the last revision or reapproval.

~~<sup>ε1</sup>Note—Footnote text inadvertently left out of Table 1 was reinserted editorially in March 2003.~~

### 1. Scope\*

1.1 This test method covers prediction of the heat buildup in rigid and flexible PVC building products above ambient air temperature, relative to black, which occurs due to absorption of the sun's energy.

NOTE 1—This test method is expected to be applicable to all types of colored plastics. The responsible subcommittee intends to broaden the scope beyond PVC when data on other materials is submitted for review.

NOTE 2—There are no ISO standards covering the primary subject matter of this test method.

1.2 Rigid PVC exterior profile extrusions for assembled windows and doors are covered in Specification D4726.

1.3 Rigid PVC exterior profiles for fencing are covered in Specification F964.

1.4 Rigid PVC siding profiles are covered in Specification D3679.

1.5 Rigid PVC soffit profiles are covered in Specification D4477.

1.6 Rigid PVC and Rigid CPVC plastic building products compounds are covered in Specification D4216.

~~1.7~~ The text of this test method references notes and footnotes which provide explanatory material. These notes and footnotes (excluding those in tables and figures) shall not be considered as requirements of this test method.

1.8 The values stated in inch-pound units are to be regarded as the standard.

1.9 *This standard does not purport to address all of the safety concerns, if any, associated with its use. It is the responsibility of the user of this standard to establish appropriate safety and health practices and determine the applicability of regulatory limitations prior to use.* Specific safety hazard statements are given in Section 7.

### 2. Referenced Documents

2.1 *ASTM Standards:*<sup>2</sup>

D883 Terminology Relating to Plastics

D1600 Terminology for Abbreviated Terms Relating to Plastics

~~D1898 Practice for Sampling Plastics~~

~~D3010 Practice for Preparing Compression-Molded Test Sample Plaques of Rigid Poly(Vinyl Chloride) Compounds<sup>0</sup>~~

~~4703 Practice for Compression Molding Thermoplastic Materials into Test Specimens, Plaques, or Sheets~~

D3679 Specification for Rigid Poly(Vinyl Chloride) (PVC) Siding

D4216 Specification for Rigid Poly(Vinyl Chloride) (PVC) and Related PVC and Chlorinated Poly(Vinyl Chloride) (CPVC)

Building Products Compounds

D4477 Specification for Rigid (Unplasticized) Poly(Vinyl Chloride) (PVC) Soffit

D4726 Specification for Rigid Poly(Vinyl Chloride) (PVC) Exterior-Profile Extrusions Used for Assembled Windows and Doors

E631 Terminology of Building Constructions

F964 Specification for Rigid Poly (Vinyl Chloride) (PVC) Exterior Profiles Used for Fencing and Railing

### 3. Terminology

3.1 Definitions—Definitions are in accordance with Terminologies D883 or E631 and abbreviations with Terminology D1600 unless otherwise indicated.

3.2 *Definitions of Terms Specific to This Standard:*

<sup>1</sup> This test method is under the jurisdiction of ASTM Committee D20 on Plastics and is the direct responsibility of Subcommittee D20.24 on Plastic Building Products. Current edition approved March 27, 2003. Published March 2003. Originally approved in 1989. Last previous edition approved in 1997 as D4803-97. DOI: 10.1520/D4803-97R02E01.

Current edition approved Nov. 1, 2010. Published January 2011. Originally approved in 1989. Last previous edition approved in 2002 as D4803 - 97 (2002)<sup>ε1</sup>. DOI: 10.1520/D4803-10.

<sup>2</sup> For referenced ASTM standards, visit the ASTM website, www.astm.org, or contact ASTM Customer Service at service@astm.org. For *Annual Book of ASTM Standards* volume information, refer to the standard's Document Summary page on the ASTM website.

\*A Summary of Changes section appears at the end of this standard.

3.2.1 *heat buildup*—the increase in temperature above that of ambient air due to the amount of energy absorbed by a specimen from the sun.

3.2.2 *temperature rise*—the increase in temperature above that of ambient (laboratory) air due to absorption of energy from a heating lamp (source).

#### 4. Summary of Test Method

4.1 The PVC product (extruded product, injection molded part, or compression molded) is cut apart to obtain a flat test specimen at least 3 by 3 by 0.060 ± 0.020 in. (76 by 76 by 1.5 ± 0.5 mm).

4.2 The test specimen is heated under the infrared reflective heat lamp to determine the temperature rise above ambient (laboratory) temperature relative to a black control sample.

4.3 The temperature rise data, obtained in the laboratory for a given test specimen, is then used to predict the heat buildup, which may occur outdoors due to the sun.

#### 5. Significance and Use

5.1 Heat buildup in PVC exterior building products due to absorption of the energy from the sun may lead to distortion problems. Heat buildup is affected by the color, emittance, absorptance, and reflectance of a product. Generally, the darker the color of the product, the more energy is absorbed and the greater is the heat buildup. However, even with the same apparent color, the heat buildup may vary due to the specific pigment system involved. The greatest heat buildup generally occurs in the color black containing carbon black pigment. The black control sample used in this test method contains 2.5 parts of furnace black per 100 parts of PVC suspension resin. The maximum temperature rise above ambient temperature for this black is 90°F (50°C) for a 45° or horizontal surface when the sun is perpendicular to the surface and 74°F (41°C) for a vertical surface assuming that the measurements were done on a cloudless day with no wind and heavy insulation on the back of the specimen.<sup>3</sup> See Appendix X1.

5.2 This test method allows the measurement of the temperature rise under a specific type heat lamp, relative to that of a black reference surface, thus predicting the heat buildup due to the sun's energy.

5.3 The test method allows prediction of heat buildup of various colors or pigment systems, or both.

5.4 This test method gives a relative heat buildup compared to black under certain defined severe conditions but does not predict actual application temperatures of the product. These will also depend on air temperature, incident angle of the sun, clouds, wind velocity, insulation, installation behind glass, etc.

#### 6. Apparatus

6.1 *Testing Apparatus*—The apparatus shall be constructed essentially as shown in Fig. 1 and shall consist of the following:

6.1.1 *Wooden Box*, opened from the top and the front and lined with 1-in. (25.4-mm) thick white rigid hydrous calcium silicate heat insulation.

6.1.2 *White Infrared Heat Lamp*, 250-W.<sup>4</sup>

6.1.3 *Thermocouple*, 40-gage Type J (iron-constantan); or equivalent.

6.1.4 *Digital Read-Out Temperature Meter*, Type J; or equivalent.

NOTE 3—The type of insulation may affect absolute temperature rise. However, the calculated values of predicted maximum heat buildup, relative to a black does not appear to be affected, based on a laboratory study comparing white rigid hydrous calcium silicate heat insulation with aluminum foil insulation having equivalent thermal resistance.

NOTE 4—The intensity of the heat lamp has an effect on absolute temperature rise, however, it does not appear to influence the calculated values of predicted maximum heat buildup relative to the black control. The 250-W infrared heat lamp was selected because a higher intensity lamp results in excessive temperature rise. This leads to excessive softening of the specimen under study, especially in the case of the black control. A lower intensity lamp requires a longer testing time and, therefore, is considered undesirable.

6.2 The thermocouple shall be inserted through a 0.125-in. (3.18-mm) hole in the bottom of the box, so that it extends 0.25 in. (6.35 mm) above the bottom surface of the box. The thermocouple bends under the weight of the specimen, but shall retain contact with the specimen when the specimen is in place. The lamp shall be installed perpendicular to the thermocouple. ~~A specimen location grid may be inscribed on the bottom of the box to facilitate centering of the thermocouple in relation to the specimen.~~

6.3 The distance from the bottom of the box to the bottom surface of the lamp shall be 15.5 ± 1 in. (39.4 ± 2.5 cm).

NOTE 5—Calculated heat buildup for the specimens is independent of the distance between the light source and the surface of the specimen. However, shorter distances lead to very high maximum equilibrium temperatures, especially for dark colors, which might cause distortion of the specimen. Larger distances between the light source and the specimen cause less test sensitivity and less reproducibility.

6.4 Install the apparatus in a room characterized by still air without drafts due to air conditioning, etc.

#### 7. Safety Precautions

7.1 The heating lamp is hot during the test. Touching it will cause burns.

<sup>3</sup> Summers and Brown, *SPE Technical Papers*, XXV, 1979, p. 403.

<sup>4</sup> Summers and Brown, *SPE Technical Papers*, XXV, 1979, p. 403.

<sup>4</sup> A G.E. heat lamp has been found satisfactory for this purpose.

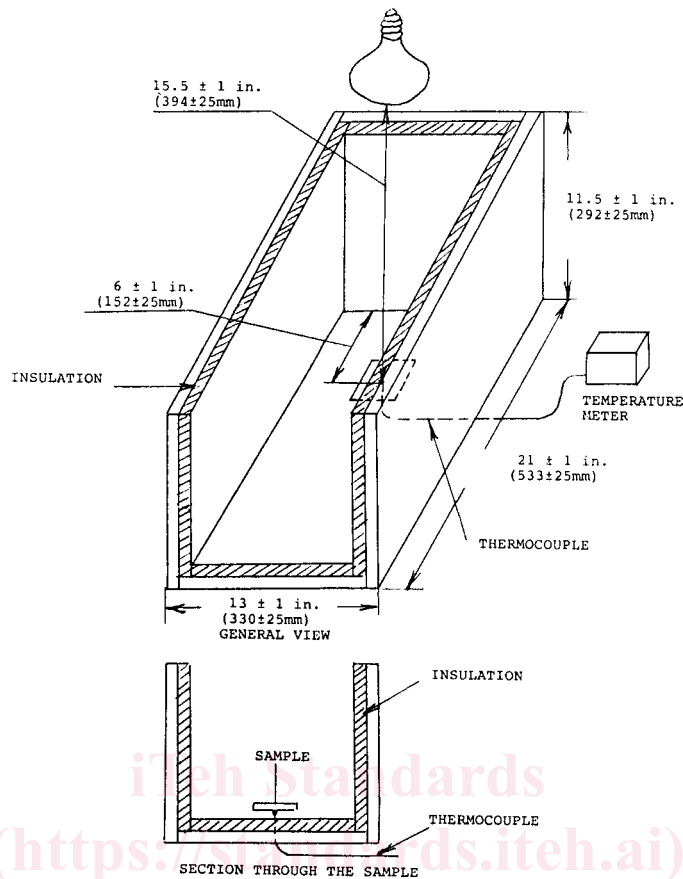

FIG. 1 Apparatus for Measuring Temperature Rise

## 8. Sampling

8.1 Select samples in accordance with Practice D1898<sup>6</sup> in a statistically acceptable manner. The samples shall be representative of the color or pigment system, or both, under study.

## 9. Test Specimens

9.1 Test flat smooth-surfaced test specimens at least 3 by 3 by  $0.060 \pm 0.020$  in. (76 by 76 by  $1.5 \pm 0.5$  mm), cut from the selected samples.

9.2 A similar size control specimen shall be prepared from any rigid PVC compound containing 2.5 parts Black Pearls 700<sup>5</sup> or equivalent furnace type carbon black without any other pigmentation. See Practice D4703.

## 10. Procedure

10.1 Maintain the ambient air temperature in the laboratory, measured 3 ft from the side of the testing box, at  $75 \pm 5^\circ\text{F}$ .

10.2 Set the specimen on the bottom of the box using sample location grid so that its center is in contact with the thermocouple. Two-sided Use two-sided adhesive tape may be used between the specimen and the box to ensure contact with the thermocouple.

10.3 Turn on the heat lamp and digital read out temperature meter.

10.4 From the temperature meter, record the equilibrium temperature of the specimen. Usually it takes no more than 30 min for the PVC specimens having thickness equal to or less than 0.075 in. (1.9 mm). See Fig. 2 for relationship of the time required to reach equilibrium temperature and the thickness of the PVC specimens.

10.5 Measure the maximum temperature of the control specimen prior to the specimens under study but within 2 h of the other temperature rise measurements.

## 11. Calculation

11.1 Temperature rise above ambient temperature:

11.1 Temperature rise above ambient temperature:

<sup>6</sup> A G.E. heat lamp has been found satisfactory for this purpose.

<sup>5</sup> Available from Cabot Corp., P.O. Box 188, Tuscola, IL 61953.