**Optics and photonics — Test methods
for telescopic systems —**

**Part 10:
Test methods for axial colour
performance**

iTeh STANDARD PREVIEW
(standards.iteh.ai)
*Optique et photonique — Méthodes d'essai pour systèmes
télescopiques —
Partie 10: Méthodes d'essai pour la performance de couleur axiale*

ISO 14490-10:2021

<https://standards.iteh.ai/catalog/standards/sist/3dade8aa-d9f5-4104-b086-e744f62eed2b/iso-14490-10-2021>



iTeh STANDARD PREVIEW
(standards.iteh.ai)

ISO 14490-10:2021
<https://standards.iteh.ai/catalog/standards/sist/3dade8aa-d9f5-4104-b086-e744f62eed2b/iso-14490-10-2021>



COPYRIGHT PROTECTED DOCUMENT

© ISO 2021

All rights reserved. Unless otherwise specified, or required in the context of its implementation, no part of this publication may be reproduced or utilized otherwise in any form or by any means, electronic or mechanical, including photocopying, or posting on the internet or an intranet, without prior written permission. Permission can be requested from either ISO at the address below or ISO's member body in the country of the requester.

ISO copyright office
CP 401 • Ch. de Blandonnet 8
CH-1214 Vernier, Geneva
Phone: +41 22 749 01 11
Email: copyright@iso.org
Website: www.iso.org

Published in Switzerland

Contents

	Page
Foreword.....	iv
Introduction.....	v
1 Scope.....	1
2 Normative references.....	1
3 Terms and definitions.....	1
4 Requirements.....	1
4.1 General.....	1
4.2 Test arrangement.....	1
4.3 Preparation and carrying out of measurements.....	2
4.4 Determination of results.....	2
4.5 Uncertainty and fundamental limit of the measurement.....	3
4.6 Test report.....	3
Annex A (informative) Measurement method for axial colour performance of the dioptric tester ...	4
Bibliography.....	6

iTeh STANDARD PREVIEW (standards.iteh.ai)

[ISO 14490-10:2021](https://standards.iteh.ai/catalog/standards/sist/3dade8aa-d9f5-4104-b086-e744f62eed2b/iso-14490-10-2021)

<https://standards.iteh.ai/catalog/standards/sist/3dade8aa-d9f5-4104-b086-e744f62eed2b/iso-14490-10-2021>

Foreword

ISO (the International Organization for Standardization) is a worldwide federation of national standards bodies (ISO member bodies). The work of preparing International Standards is normally carried out through ISO technical committees. Each member body interested in a subject for which a technical committee has been established has the right to be represented on that committee. International organizations, governmental and non-governmental, in liaison with ISO, also take part in the work. ISO collaborates closely with the International Electrotechnical Commission (IEC) on all matters of electrotechnical standardization.

The procedures used to develop this document and those intended for its further maintenance are described in the ISO/IEC Directives, Part 1. In particular, the different approval criteria needed for the different types of ISO documents should be noted. This document was drafted in accordance with the editorial rules of the ISO/IEC Directives, Part 2 (see www.iso.org/directives).

Attention is drawn to the possibility that some of the elements of this document may be the subject of patent rights. ISO shall not be held responsible for identifying any or all such patent rights. Details of any patent rights identified during the development of the document will be in the Introduction and/or on the ISO list of patent declarations received (see www.iso.org/patents).

Any trade name used in this document is information given for the convenience of users and does not constitute an endorsement.

For an explanation of the voluntary nature of standards, the meaning of ISO specific terms and expressions related to conformity assessment, as well as information about ISO's adherence to the World Trade Organization (WTO) principles in the Technical Barriers to Trade (TBT), see www.iso.org/iso/foreword.html.

This document was prepared by Technical Committee ISO/TC 172, *Optics and photonics*, Subcommittee SC 4, *Telescopic systems*.

A list of all parts in the ISO 14490 series can be found on the ISO website.

Any feedback or questions on this document should be directed to the user's national standards body. A complete listing of these bodies can be found at www.iso.org/members.html.

Introduction

ISO 14490-7 mentions several characteristics to determine image quality of telescopic systems besides the limit of resolution evaluation. One unmentioned characteristic in ISO 14490-7 is the “axial colour performance” which may be noted by the user as a coloured halo around objects or even a hue of objects in the centre of the field of view. Typically, the axial colour performance also affects the colour performance in the entire field of view.

The axial colour performance of a telescopic system is mainly determined by two major intrinsic contributions. These are spherical aberration and axial chromatic aberration. According to ISO 10934 axial chromatic aberration is defined as the aberration of a lens, by which light of different wavelengths is focused at different points along the optical axis. The axial chromatic aberration originates from the intrinsic difference of the refractive index of glass as a function of the incident wavelength of light, i.e. the dispersion. For a singlet (positive) lens the axial chromatic aberration yields different focal lengths for different wavelengths, which may also be called chromatic focal shift. Multi-lens groups or assemblies are designed to reduce and compensate this focal shift to go below the intrinsic dispersion of singlet systems. The footprint of the axial chromatic correction of lenses is partially classified by terms like “achromatic” or “apochromatic” lenses.

Axial chromatic aberration originates from the dispersion of the lens material. In contrast, spherical aberration is related to the geometry of a lens and is classified as a monochromatic aberration. Spherical aberration causes rays in the image space to intersect the optical axis before or after the image point formed by the paraxial rays (see also ISO 10934). As a consequence the “best focus” is not well defined even for a monochromatic evaluation of a system. From that it is obvious that the measurement of a pure axial chromatic aberration may be influenced by spherical aberration.

This document thus describes the measurement of the joint effect of these two major contributions since in practical use an observer will not be able to separate these two effects. However, for deeper analysis in the laboratory the two effects may be analysed separately.

In the case of afocal systems, such as telescopes, the axial chromatic aberration as well as the spherical aberration of the objective lens is imaged to infinity by the eyepiece (looked at by the user) and can be measured in dioptres. The measurement of the axial colour performance as described in this document may be combined with a monochromatic evaluation of the modulation transfer function (MTF, see ISO 9336-3) to obtain an overall figure for the imaging performance of a telescopic system.

iTeh STANDARD PREVIEW
(standards.iteh.ai)

ISO 14490-10:2021

<https://standards.iteh.ai/catalog/standards/sist/3dade8aa-d9f5-4104-b086-e744f62eed2b/iso-14490-10-2021>

Optics and photonics — Test methods for telescopic systems —

Part 10: Test methods for axial colour performance

1 Scope

This document specifies the test method for the measurement of the axial colour performance which includes axial chromatic aberration and spherical aberration of telescopic systems and observational telescopic instruments.

2 Normative references

The following documents are referred to in the text in such a way that some or all of their content constitutes requirements of this document. For dated references, only the edition cited applies. For undated references, the latest edition of the referenced document (including any amendments) applies.

ISO 14132-1, *Optics and photonics — Vocabulary for telescopic systems — Part 1: General terms and alphabetical indexes of terms in ISO 14132*

ISO 14490-1:2005, *Optics and optical instruments — Test methods for telescopic systems — Part 1: Test methods for basic characteristics*

ISO 14490-10:2021

<https://standards.iteh.ai/catalog/standards/sist/3dade8aa-d9f5-4104-b086-e744f62eed2b/iso-14490-10-2021>

3 Terms and definitions

For the purposes of this document, the terms and definitions given in ISO 14132-1 apply.

ISO and IEC maintain terminological databases for use in standardization at the following addresses:

- ISO Online browsing platform: available at <https://www.iso.org/obp>
- IEC Electropedia: available at <https://www.electropedia.org/>

4 Requirements

4.1 General

All measurements shall be performed on optical axis, i.e. the target shall be situated at the centre of the field of the specimen. The measurement principle relies on the evaluation of the best focus position for different wavelengths. Therefore the target size and structure have to be suitable to evaluate the best focus but do not necessarily need to contain a structure at the theoretical resolution limit of the specimen.

4.2 Test arrangement

The measurement of the axial colour performance shall be carried out with the test arrangement shown in [Figure 1](#). It ideally consists of a negative back lit test target screen at the focal plane of a collimator. The light source has to be bright enough to guarantee sufficient luminance after spectral filtering. In addition a dioptric tester is used for analysis.

The test arrangement shall provide three different wavelengths: green ($e = 546 \text{ nm}$), blue ($F' = 480 \text{ nm}$) and red ($C' = 644 \text{ nm}$). This can be realized with narrow band filters (full width half maximum $< 20 \text{ nm}$) either between test target and light source, after the test specimen or after the dioptric tester. The three different colours are used to determine the colour-dependent axial focal shift.

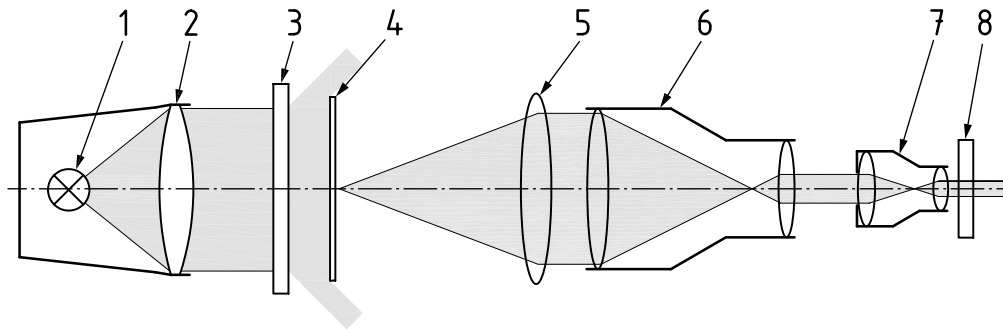

Key

- | | | | |
|---|--|---|-----------------|
| 1 | light source | 5 | collimator lens |
| 2 | condenser | 6 | test specimen |
| 3 | diffusing plate | 7 | dioptric tester |
| 4 | test target screen with test target groups | 8 | spectral filter |

Figure 1 — Test arrangement for the measurement of axial colour performance

iTeh STANDARD PREVIEW

The collimator shall have a sufficiently small axial chromatic aberration. For a rough estimation the chromatic aberration in dioptres times the square of the magnification of the test specimen should be smaller than $0,05 \text{ m}^{-1}$ (dioptres). Ideally, reflective types of collimators [e.g. (off-axis) parabolic mirrors] should be used.

ISO 14490-10:2021

The dioptric tester shall have a sufficiently small axial chromatic aberration. In general, this should be smaller than $0,05 \text{ m}^{-1}$. See [Annex A](#). Typically, dioptric testers with higher magnification of around $6\times$ provide higher dioptrre precision.

4.3 Preparation and carrying out of measurements

As a first step the dioptric tester shall be set to 0 m^{-1} and the eyepiece of the dioptric tester shall be focused for compensating aberrations of the eye of the examiner at green illumination. This will be done by using a faint diffusive plate in front of the dioptric tester and focusing on the dioptric tester’s reticle. The examiner shall focus from the positive dioptrre side to avoid accommodation.

The test specimen shall be focused to 0 m^{-1} onto the test target located in the centre of the field of view. The so defined state is the reference for the following measurements.

As a next step the defocus of the test specimen for blue light shall be measured by refocusing the dioptric tester. The result for the axial chromatic focal shift for the blue wavelength in m^{-1} shall be noted.

As a last step the previous steps shall be repeated by using the red light. The result for the axial chromatic focal shift for the red wavelength in m^{-1} shall be noted.

For high precision measurements, the chromatic aberration of the examiner’s eye shall be compensated for at blue and red wavelengths as defined in [4.2](#).

4.4 Determination of results

As an overall result of the measurement, the focal shift of blue to green light and red to green light shall be stated in m^{-1} .

4.5 Uncertainty and fundamental limit of the measurement

The uncertainty of the measurement is strongly influenced by the exit pupil diameter and the imaging quality of the test specimen, especially its residual spherical aberration, but also coma and astigmatism.

While the image quality cannot be analysed in general, the fundamental precision limit of the described measurement is given by the Rayleigh depth of focus. Based on the criterion for the depth of field for microscope objectives (see also ISO 19012-2) and by using the Newton formula for thin lenses, the Rayleigh depth of focus, d_{of} , in m^{-1} is given by the following [Formula \(1\)](#):

$$d_{of} = \pm 2n\lambda / D'^2 \quad (1)$$

where

n is the refractive index of the surrounding medium;

λ is the wavelength of the reference light;

D' is the exit pupil diameter of the test specimen.

For green light (e -line $\lambda = 546$ nm) and for D' in mm the depth of focus d_{of} in m^{-1} can be estimated by [Formula \(2\)](#):

$$d_{of} = \pm 1,1 / D'^2 \quad (2)$$

The Rayleigh depth of focus, d_{of} represents the fundamental precision limit of the measurement.

4.6 Test report

A test report shall be presented and shall include the general information specified in ISO 14490-1:2005, Clause 13, the result of the test in table format and/or in plot format and information on the test target used for the test.

Annex A (informative)

Measurement method for axial colour performance of the dioptric tester

A.1 General

The basic instrument for measuring the axial colour performance is the dioptric tester. To estimate the axial colour performance of the dioptric tester itself the following procedure is suggested.

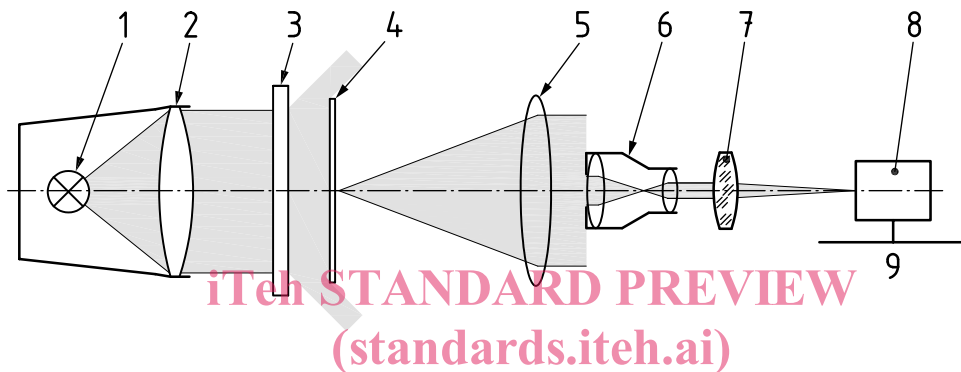

Key

- | | | | |
|---|---|---|--|
| 1 | light source | 5 | collimator lens |
| 2 | condenser | 6 | dioptric tester as test specimen |
| 3 | diffusing plate | 7 | image analyser collimator (decollimator) |
| 4 | test target screen with pinhole or test target groups and spectral filter | 8 | image analyser (camera) |
| | | 9 | image analyser slideway |

Figure A.1 — Test arrangement for the measurement of axial colour performance of the dioptric tester

A.2 Test arrangement

The measurement of the axial colour performance of the dioptric tester shall be carried out with the test arrangement shown in [Figure A.1](#) (see also [Figure 1](#) for comparison). The left part of [Figure A.1](#) (i.e. Key 1 to 5) are identical to the parts shown in [Figure 1](#). Thus the requirements for these parts in [Figure 1](#) and [Figure A.1](#) are identical. The test specimen in the setup shown in [Figure A.1](#) is the dioptric tester. In addition, an image analyser collimator (decollimator), an image analyser (camera) and an image analyser slideway is used. The image analyser collimator (decollimator) shall have a sufficiently small axial chromatic aberration, typically reversed microscope objectives are used for this purpose. The slideway has to be a high precision slideway driven by micrometre screws.

A.3 Preparation and carrying out of measurement

As a first step the dioptric tester has to be set to 0 m⁻¹ at green light and has to be placed after the collimator lens. Then, the image analyser collimator (decollimator) has to be placed at the exit pupil of the dioptric tester resulting in a focal spot. After that, the image analyser (camera) has to be positioned along the optical axis to find the best focus spot. The position of the green best focus spot along the optical axis is the datum for the following measurements and should be nulled if possible.