Woodworking machines — Safety —
Part 3:
Numerically controlled (NC/CNC)
boring and routing machines

Machines à bois — Sécurité —

Partie 3: Perceuses et défonceuses à Commande Numérique (CN/CNC)
iTeh STANDARD PREVIEW
(standards.iteh.ai)

ISO 19085-3:2021

<https://standards.iteh.ai/catalog/standards/sist/363edb14-c2e2-42d1-9198-f89d50de3f2e/iso-19085-3-2021>



iTeh STANDARD PREVIEW (standards.iteh.ai)

ISO 19085-3:2021

<https://standards.iteh.ai/catalog/standards/sist/363edb14-c2e2-42d1-9198-f89d50de3f2e/iso-19085-3-2021>



COPYRIGHT PROTECTED DOCUMENT

© ISO 2021

All rights reserved. Unless otherwise specified, or required in the context of its implementation, no part of this publication may be reproduced or utilized otherwise in any form or by any means, electronic or mechanical, including photocopying, or posting on the internet or an intranet, without prior written permission. Permission can be requested from either ISO at the address below or ISO's member body in the country of the requester.

ISO copyright office
CP 401 • Ch. de Blandonnet 8
CH-1214 Vernier, Geneva
Phone: +41 22 749 01 11
Email: copyright@iso.org
Website: www.iso.org

Published in Switzerland

Contents

	Page
Foreword	v
Introduction	vi
1 Scope	1
2 Normative references	2
3 Terms and definitions	3
4 Safety requirements and measures for controls	6
4.1 Safety and reliability of control systems.....	6
4.2 Control devices.....	6
4.2.1 General.....	7
4.2.2 Hand-held control sets.....	7
4.3 Start.....	7
4.3.1 Direct start.....	7
4.3.2 Start via control power-on.....	7
4.4 Safe stops.....	8
4.4.1 General.....	8
4.4.2 Normal stop.....	8
4.4.3 Operational stop.....	8
4.4.4 Emergency stop.....	8
4.5 Braking function of tools.....	8
4.6 Mode selection.....	8
4.6.1 General.....	8
4.6.2 Machine setting mode [MODE 2].....	8
4.6.3 Clamping device manual positioning mode [MODE 3].....	9
4.6.4 Boring units positioning mode [MODE 4].....	9
4.7 Tool speed changing.....	9
4.7.1 Speed changing by shifting the belts on the pulleys.....	9
4.7.2 Speed changing by incremental speed change motor.....	9
4.7.3 Infinitely variable speed by frequency inverter.....	9
4.8 Failure of any power supply.....	10
4.9 Manual reset control.....	10
4.10 Standstill detection and monitoring.....	10
4.11 Machine moving parts speed monitoring.....	10
4.12 Time delay.....	10
4.13 Tele-service.....	10
5 Safety requirements and measures for protection against mechanical hazards	10
5.1 Stability.....	10
5.2 Risk of break-up during operation.....	10
5.3 Tool and tool fixing design.....	11
5.3.1 General.....	11
5.3.2 Spindle locking.....	11
5.3.3 Circular saw blade fixing device.....	11
5.3.4 Flange dimension for circular saw blades.....	11
5.4 Braking.....	11
5.4.1 Braking of tools.....	11
5.4.2 Maximum run-down time.....	11
5.4.3 Brake release.....	11
5.5 Safeguards.....	11
5.5.1 Fixed guards.....	11
5.5.2 Interlocking moveable guards.....	12
5.5.3 Hold-to-run control.....	12
5.5.4 Two-hand control.....	12
5.5.5 Electro-sensitive protective equipment (ESPE).....	12

5.5.6	Pressure-sensitive protective equipment (PSPE)	13
5.5.7	Enabling control	13
5.6	Prevention of access to hazardous moving parts	13
5.6.1	General	13
5.6.2	Safeguarding of all machine sides except the loading/unloading zone	13
5.6.3	Safeguarding of the loading/unloading zones	14
5.6.4	Measures against access to the rear of the machine from un/loading zone	24
5.6.5	Minimum clearances at the loading/unloading zone	27
5.7	Impact hazard	27
5.8	Clamping devices	27
5.9	Measures against ejection	28
5.9.1	General	28
5.9.2	Guards materials and characteristics	30
5.9.3	Curtains	31
5.10	Workpiece support and guides	32
6	Safety requirements and measures for protection against other hazards	32
6.1	Fire	32
6.2	Noise	32
6.2.1	Noise reduction at the design stage	32
6.2.2	Noise emission measurement and declaration	32
6.3	Emission of chips and dust	32
6.4	Electricity	32
6.5	Ergonomics and handling	32
6.6	Lighting	33
6.7	Pneumatics	33
6.8	Hydraulics	33
6.9	Electromagnetic compatibility	33
6.10	Laser	33
6.11	Static electricity	33
6.12	Errors of fitting	33
6.13	Isolation	33
6.14	Maintenance	33
6.15	Relevant but not significant hazards	33
7	Information for use	33
7.1	Warning devices	33
7.2	Marking	34
7.2.1	General	34
7.2.2	Additional markings	34
7.3	Instruction handbook	34
7.3.1	General	34
7.3.2	Additional information	34
	Annex A (informative) List of significant hazards	36
	Annex B (informative) Performance levels required	38
	Annex C (normative) Stability test	40
	Annex D (normative) Test for braking function	41
	Annex E (normative) Impact test for guards	42
	Annex F (normative) Noise test code	43
	Annex G (normative) Dynamic test for pressure-sensitive bumpers, edges, trip bars, trip plates	48
	Annex H (informative) Examples of safeguarding concepts for different machine designs	56
	Annex I (normative) Impact test for curtains	74
	Annex J (normative) Wear test for curtains	79
	Bibliography	83

iTech STANDARD PREVIEW
(standards.iteh.ai)

ISO 19085-3:2021
<https://standards.iteh.ai/catalog/standards/sist/363edb14-c2e2-42d1-9198-f89d50de3f2e/iso-19085-3-2021>

Foreword

ISO (the International Organization for Standardization) is a worldwide federation of national standards bodies (ISO member bodies). The work of preparing International Standards is normally carried out through ISO technical committees. Each member body interested in a subject for which a technical committee has been established has the right to be represented on that committee. International organizations, governmental and non-governmental, in liaison with ISO, also take part in the work. ISO collaborates closely with the International Electrotechnical Commission (IEC) on all matters of electrotechnical standardization.

The procedures used to develop this document and those intended for its further maintenance are described in the ISO/IEC Directives, Part 1. In particular, the different approval criteria needed for the different types of ISO documents should be noted. This document was drafted in accordance with the editorial rules of the ISO/IEC Directives, Part 2 (see www.iso.org/directives).

Attention is drawn to the possibility that some of the elements of this document may be the subject of patent rights. ISO shall not be held responsible for identifying any or all such patent rights. Details of any patent rights identified during the development of the document will be in the Introduction and/or on the ISO list of patent declarations received (see www.iso.org/patents).

Any trade name used in this document is information given for the convenience of users and does not constitute an endorsement.

For an explanation of the voluntary nature of standards, the meaning of ISO specific terms and expressions related to conformity assessment, as well as information about ISO's adherence to the World Trade Organization (WTO) principles in the Technical Barriers to Trade (TBT), see www.iso.org/iso/foreword.html (standards.iteh.ai).

This document was prepared by Technical Committee ISO/TC 39, *Machine tools*, Subcommittee SC 4, *Woodworking machines*, in collaboration with the European Committee for Standardization (CEN) Technical Committee CEN/TC 142, *Woodworking machines – Safety*, in accordance with the Agreement on technical cooperation between ISO and CEN (Vienna Agreement).

This second edition cancels and replaces the first edition (ISO 19085-3:2017), which has been technically revised.

The main changes are as follows:

- in the Scope, machines are “intended for continuous production use”, in line with ISO 19085-1:2021;
- the list of significant hazards has been moved to [Annex A](#);
- the structure has been simplified, in line with ISO 19085-1:2021, in particular in [5.6](#);
- the machines designs covered have been clarified, and the relevant requirements have been made more explicit for each design in new [5.6.3](#), with examples figures in the new [Annex H](#);
- the requirements against access to the rear through the un/loading zone in [5.6.4](#) have been improved and moved from old subclause 6.6.2.2.3.1 to [5.6.4](#);
- [Subclause 6.2](#) has been rewritten, and a new updated full Noise Test Code has been introduced in [Annex F](#);

This document is intended to be used in conjunction with ISO 19085-1:2021, which gives requirements common to different machine types.

A list of all parts in the ISO 19085 series can be found on the ISO website.

Any feedback or questions on this document should be directed to the user's national standards body. A complete listing of these bodies can be found at www.iso.org/members.html.

Introduction

The ISO 19085 series provides technical safety requirements for the design and construction of woodworking machinery. It concerns designers, manufacturers, suppliers and importers of the machines specified in the Scope. It also includes a list of informative items to be provided to the user by the manufacturer.

This document is a type-C standard as stated in ISO 12100.

This document is of relevance, in particular, for the following stakeholder groups representing the market players with regard to machinery safety:

- machine manufacturers (small, medium and large enterprises);
- health and safety bodies (regulators, accident prevention organisations, market surveillance etc.)

Others can be affected by the level of machinery safety achieved with the means of the document by the above-mentioned stakeholder groups:

- machine users/employers (small, medium and large enterprises);
- machine users/employees (e.g. trade unions, organizations for people with special needs);
- service providers, e. g. for maintenance (small, medium and large enterprises);
- consumers (in case of machinery intended for use by consumers).

The above-mentioned stakeholder groups have been given the possibility to participate at the drafting process of this document.

The machinery concerned and the extent to which hazards, hazardous situations or hazardous events are covered are indicated in the Scope of this document.

When requirements of this type-C standard are different from those which are stated in type-A or type-B standards, the requirements of this type-C standard take precedence over the requirements of the other standards for machines that have been designed and built according to the requirements of this type-C standard.

The full set of requirements for a particular type of woodworking machine are those given in the part of ISO 19085 applicable to that type, together with the relevant requirements from ISO 19085-1, to the extent specified in the Scope of the applicable part of ISO 19085.

As far as possible, the safety requirements of parts of the ISO 19085 series refer to the relevant subclauses of ISO 19085-1. Each part contains replacements and additions to the common requirements given in ISO 19085-1.

[Clauses 1 to 3](#) are specific to each part and, therefore, replace ISO 19085-1:2021, Clauses 1 to 3.

For [Clauses 4 to 7](#) and the annexes, ISO 19085-1:2021, Clauses 4 to 7 and Annexes, each subclause can be:

- confirm as a whole;
- confirm with additions;
- exclude in total; or
- replace with specific text.

This is indicated by one of the following possible statements:

- “ISO 19085-1:2021, [subclause/Annex], applies”;

- “ISO 19085-1:2021, [subclause/Annex], applies with the following additions.” or “ISO 19085-1:2021, [subclause/Annex], applies with the following additions, subdivided into further specific subclauses.”;
- “ISO 19085-1:2021, [subclause/Annex], does not apply.”;
- “ISO 19085-1:2021, [subclause/Annex], is replaced by the following text.” or “ISO 19085-1:2021, [subclause/Annex], is replaced by the following text, subdivided into further specific subclauses.”.

Other subclauses and annexes specific to this document are indicated by the introductory sentence: “Subclause/Annex specific to this document.”.

iTeh STANDARD PREVIEW (standards.iteh.ai)

[ISO 19085-3:2021](https://standards.iteh.ai/catalog/standards/sist/363edb14-c2e2-42d1-9198-f89d50de3f2e/iso-19085-3-2021)

<https://standards.iteh.ai/catalog/standards/sist/363edb14-c2e2-42d1-9198-f89d50de3f2e/iso-19085-3-2021>

iTeh STANDARD PREVIEW
(standards.iteh.ai)

ISO 19085-3:2021

<https://standards.iteh.ai/catalog/standards/sist/363edb14-c2e2-42d1-9198-f89d50de3f2e/iso-19085-3-2021>

Woodworking machines — Safety —

Part 3: Numerically controlled (NC/CNC) boring and routing machines

1 Scope

This document gives the safety requirements and measures for numerically controlled (NC/CNC) boring machines, NC/CNC routing machines and NC/CNC boring and routing machines (as defined in [3.2](#), [3.3](#) and [3.4](#)), capable of continuous production use, hereinafter referred to as "machines".

This document deals with all significant hazards, hazardous situations and events, listed in [Annex A](#), relevant to the machines when they are operated, adjusted and maintained as intended and under the conditions foreseen by the manufacturer including reasonably foreseeable misuse. Also, transport, assembly, dismantling, disabling and scrapping phases have been taken into account.

This document is also applicable to machines fitted with one or more of the following devices/additional working units, whose hazards have been dealt with:

- additional working units for sawing, sanding, assembling or dowel inserting;
- fixed or movable workpiece support;
- mechanical, pneumatic, hydraulic or vacuum workpiece clamping;
- automatic tool change devices.

It is also applicable to machines fitted with edge-banding equipment, even if the relevant specific hazards have not been dealt with.

NOTE For the risk assessment needed for the edge-banding equipment, ISO 19085-17 can be useful.

Machines covered in this document are designed for workpieces consisting of:

- solid wood;
- material with similar physical characteristics to wood (see ISO 19085-1:2021, 3.2);
- gypsum boards, gypsum bounded fibreboards, cardboard;
- matrix engineered mineral boards, silicate boards;
- composite materials with core consisting of polyurethane or mineral material laminated with light alloy;
- polymer-matrix composite materials and reinforced thermoplastic/thermoset/elastomeric materials;
- aluminium light alloy profiles;
- aluminium light alloy plates with a maximum thickness of 10 mm;
- composite boards made from the materials listed above.

This document does not deal with specific hazards related to:

- use of grinding wheels;
- ejection through openings guarded by curtains on machines where the height of the opening in the enclosure above the workpiece support exceeds 700 mm;
- ejection due to failure of milling tools with a cutting circle diameter equal to or greater than 16 mm and sawing tools not conforming to EN 847-1:2017 and EN 847-2:2017;
- the combination of a single machine being used with other machines (as a part of a line);
- integrated workpiece loading/unloading systems (e.g. robots).

This document is not applicable to:

- single spindle hand fed or integrated fed routing machines;
- machines intended for use in potentially explosive atmosphere;
- machines manufactured prior to its publication.

2 Normative references

The following documents are referred to in the text in such a way that some or all of their content constitutes requirements of this document. For dated references, only the edition cited applies. For undated references, the latest edition of the referenced document (including any amendments) applies.

ISO 2602:1980, *Statistical interpretation of test results — Estimation of the mean — Confidence interval*

ISO 4413:2010, *Hydraulic fluid power — General rules and safety requirements for systems and their components*

ISO 4414:2010, *Pneumatic fluid power — General rules and safety requirements for systems and their components*

ISO 12100:2010, *Safety of machinery — General principles for design — Risk assessment and risk reduction*

ISO 19085-1:2021, *Woodworking machines — Safety — Part 1: Common requirements*

ISO 13849-1:2015, *Safety of machinery — Safety-related parts of control systems — Part 1: General principles for design*

ISO 13856-3:2013, *Safety of machinery — Pressure-sensitive protective devices — Part 3: General principles for design and testing of pressure-sensitive bumpers, plates, wires and similar devices*

IEC 60204-1:2016, *Safety of machinery — Electrical equipment of machines — Part 1: General requirements*

IEC 61496-2:2013, *Safety of machinery — Electro-sensitive protective equipment — Part 2: Particular requirements for equipment using active opto-electronic protective devices (AOPDs)*

IEC 61496-3:2018, *Safety of machinery — Electro-sensitive protective equipment — Part 3: Particular requirements for Active Opto-electronic Protective Devices responsive to Diffuse Reflection (AOPDDR)*

EN 847-1:2017, *Tools for woodworking — Safety requirements — Part 1: Milling tools, circular saw blades*

EN 847-2:2017, *Tools for woodworking — Safety requirements — Part 2: Requirements for the shank of shank mounted milling tools /circular saw blades*

3 Terms and definitions

For the purposes of this document, the terms and definitions given in ISO 12100:2010, ISO 13849-1:2015, ISO 19085-1:2021 and the following apply.

ISO and IEC maintain terminology databases for use in standardization at the following addresses:

- ISO Online browsing platform: available at <https://www.iso.org/obp>
- IEC Electropedia: available at <https://www.electropedia.org/>

3.1

numerical control

NC

CNC

automatic control of a process by a device that makes use of numerical data

Note 1 to entry: In the CNC (“computerized numerical control”), the numerical data can be changed with a computer.

3.2

numerically controlled boring and routing machine

NC/CNC boring and routing machine

integrated fed machine designed for the machining of workpieces by the use of milling tools and boring tools having at least two orthogonal axes programmable by the user (e.g. X, Y) for positioning and/or machining, where the axes operate in accordance with an NC/CNC work programme

Note 1 to entry: Examples of different machine designs covered by this document are illustrated, without safeguarding devices, in [Figures 1](#) to [6](#).

3.3

numerically controlled boring machine

NC/CNC boring machine

integrated fed machine designed for the machining of workpieces by the use of boring tools having at least two orthogonal axes programmable by the user (e.g. X, Y) for positioning and/or machining, where the axes operate in accordance with an NC/CNC work programme

3.4

numerically controlled routing machine

NC/CNC routing machine

integrated fed machine designed for the machining of workpieces by the use of milling tools having at least two orthogonal axes programmable by the user (e.g. X, Y) for positioning and/or machining, where the axes operate in accordance with an NC/CNC work programme

3.5

loading/unloading zone

area close to the machine accessible to the operator for workpiece loading and/or unloading

3.6

machine setting mode

MODE 2

condition with safeguards disabled for setting, programming, fault finding, program verification, testing and manually controlled non-sequential operation of the machine

3.7

clamping device manual positioning mode

MODE 3

condition with safeguards disabled for manual positioning of clamping devices with laser indication

3.8
boring units positioning mode
MODE 4

condition with safeguards disabled for manual change of boring bits on boring machines only

3.9
jog control

control device for momentary activation of a function or a movement

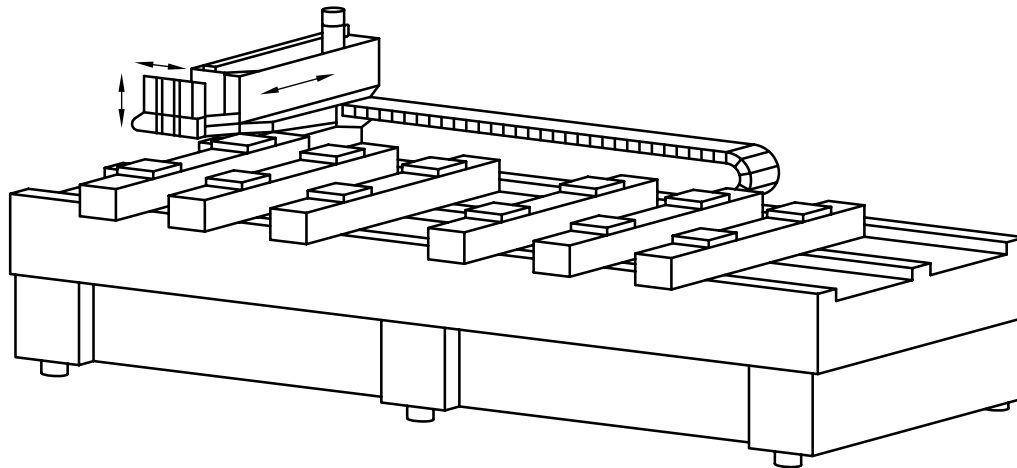

Figure 1 — Example of a C frame machine with fixed table and moving machining head

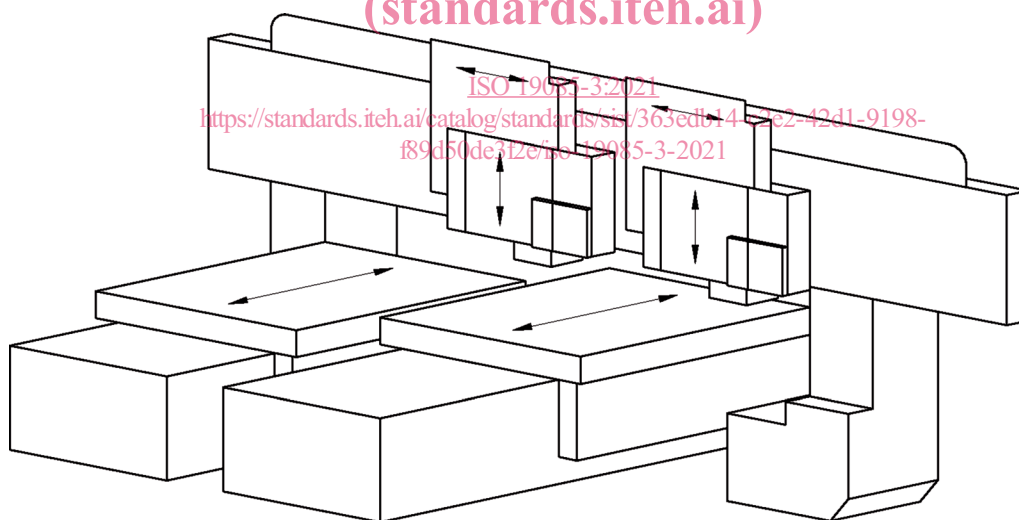

Figure 2 — Example of portal frame machine with moving tables, fixed portal, moving machining heads

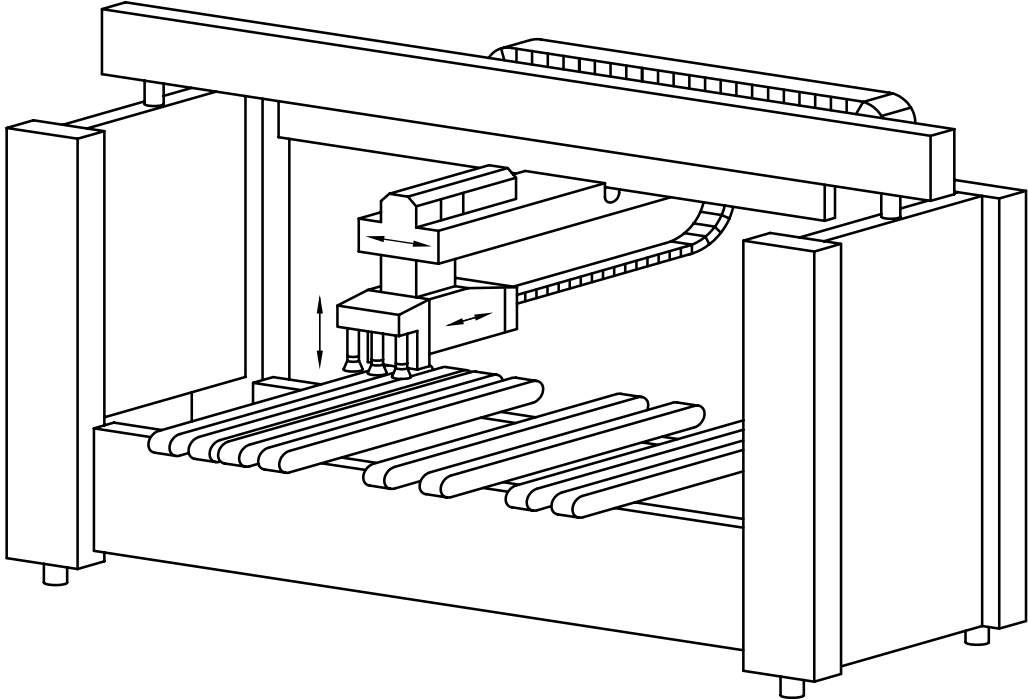

Figure 3 — Example of portal frame machine with fixed portal, feeding belts, moving machining head

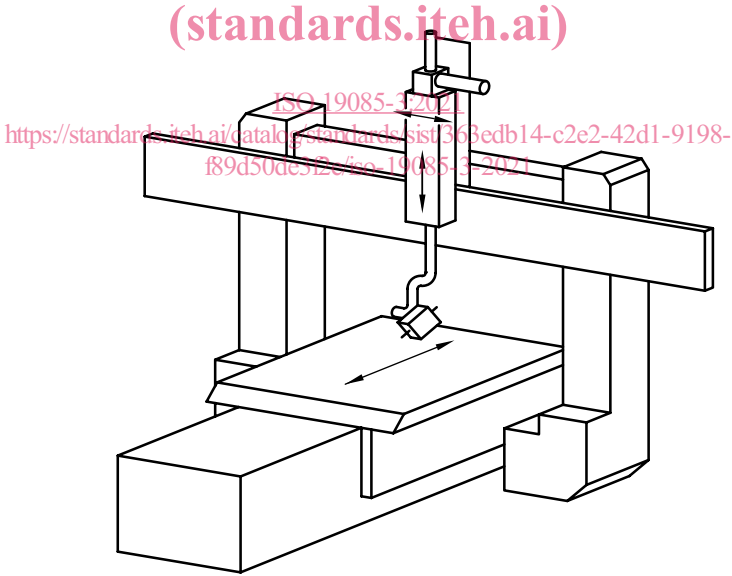

Figure 4 — Example of a machining centre with moving table, fixed portal, moving machining head

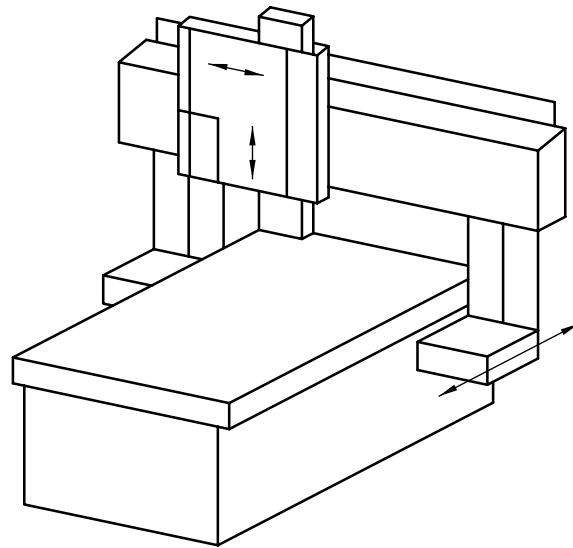

Figure 5 — Example of portal frame machine with fixed table, moving portal, moving machining head

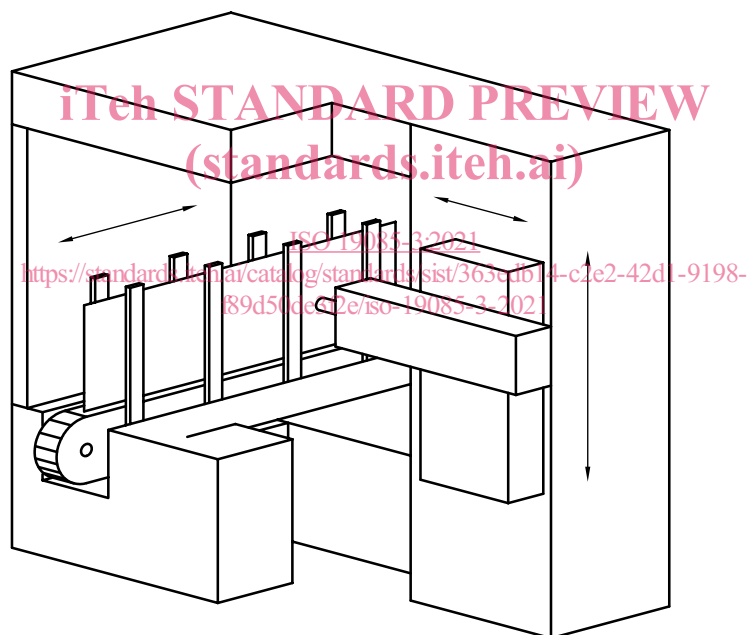

Figure 6 — Example of a through-feed vertical machine with moving workpiece, fixed frame, moving machining head

4 Safety requirements and measures for controls

4.1 Safety and reliability of control systems

ISO 19085-1:2021, 4.1, applies with the following additions.

Table B.1 replaces ISO 19085-1:2021, Table B.1.

4.2 Control devices

ISO 19085-1:2021, 4.2, applies with the following additions, subdivided into further specific subclauses.

4.2.1 General

The control devices for control power-on, operational and normal stop shall be located at the operator's position adjacent to the control display (at the main control panel).

Hold-to-run control devices and/or enabling control devices for tool or axes movements shall be located on the main control panel and/or on a hand-held set of controls connected to the machine by cable or wireless;

An emergency stop control device shall be provided at each working station and, in particular, at each of the following positions:

- a) at the main control panel;
- b) at the hand-held control set;
- c) adjacent to all hold-to-run control devices;
- d) adjacent to all cycle start control devices;
- e) at the workpiece loading and unloading station;
- f) inside any enclosure fitted with access door required in [5.6.2](#);
- g) close to or inside any tool magazine separated from the machining area and under power during loading and unloading of the tools.

If the distance between two of the positions above is less than 1 m, only one emergency stop control device is required instead of two.

Verification: By checking the relevant drawings and/or circuit diagrams, inspection of the machine and relevant functional testing of the machine.

<https://standards.iteh.ai/catalog/standards/sist/363edb14-c2e2-42d1-9198-f89d50de3f2e/iso-19085-3-2021>

4.2.2 Hand-held control sets

Additional control devices for cycle start not including reset function, for operational stop and for normal stop may be provided on hand-held control sets with or without cable connection, taking account of the requirements of [4.4.4](#) for emergency stop. Reset function control devices, control power-on control devices and mode selector shall not be fitted on hand-held control sets.

When a wireless control set loses its connection to the machine, an emergency stop shall be automatically activated. The SRP/CS for the emergency stop activation in case of wireless control disconnection shall achieve $PL_r = c$.

Verification: By checking the relevant drawings and/or circuit diagrams, inspection of the machine and relevant functional testing of the machine.

4.3 Start

4.3.1 Direct start

ISO 19085-1:2021, 4.3.1, does not apply.

4.3.2 Start via control power-on

ISO 19085-1:2021, 4.3.2, applies.