**Woodworking machines — Safety —
Part 17:
Edge banding machines fed by chains**

Machines à bois — Sécurité —

Partie 17: Machines à plaquer sur chant à alimentation par chaînes

iTeh STANDARD PREVIEW
(standards.iteh.ai)

[ISO 19085-17:2021](https://standards.iteh.ai/catalog/standards/sist/33348b15-dee0-441a-9bb4-ecb804af5bdd/iso-19085-17-2021)

<https://standards.iteh.ai/catalog/standards/sist/33348b15-dee0-441a-9bb4-ecb804af5bdd/iso-19085-17-2021>



iTeh STANDARD PREVIEW
(standards.iteh.ai)

ISO 19085-17:2021

<https://standards.iteh.ai/catalog/standards/sist/33348b15-dee0-441a-9bb4-ecb804af5bdd/iso-19085-17-2021>



COPYRIGHT PROTECTED DOCUMENT

© ISO 2021

All rights reserved. Unless otherwise specified, or required in the context of its implementation, no part of this publication may be reproduced or utilized otherwise in any form or by any means, electronic or mechanical, including photocopying, or posting on the internet or an intranet, without prior written permission. Permission can be requested from either ISO at the address below or ISO's member body in the country of the requester.

ISO copyright office
CP 401 • Ch. de Blandonnet 8
CH-1214 Vernier, Geneva
Phone: +41 22 749 01 11
Email: copyright@iso.org
Website: www.iso.org

Published in Switzerland

Contents

	Page
Foreword	vi
Introduction	vii
1 Scope	1
2 Normative references	2
3 Terms and definitions	3
4 Safety requirements and measures for controls	9
4.1 Safety and reliability of control systems.....	9
4.2 Control devices.....	9
4.3 Start.....	9
4.3.1 Direct start.....	9
4.3.2 Start via control power-on.....	10
4.3.3 Integrated feed.....	10
4.4 Safe stops.....	10
4.4.1 General.....	10
4.4.2 Normal stop.....	10
4.4.3 Operational stop.....	11
4.4.4 Emergency stop.....	11
4.5 Braking function of tools.....	11
4.6 Mode selection.....	11
4.6.1 Units Manual adjustments mode (MODE 2).....	12
4.6.2 Fine adjustment mode (MODE 3).....	12
4.6.3 Feed chains greasing mode (MODE 4).....	13
4.7 Tool speed changing.....	14
4.7.1 Speed changing by shifting the belts on the pulleys.....	14
4.7.2 Speed changing by incremental speed change motor.....	14
4.7.3 Infinitely variable speed by frequency inverter.....	14
4.8 Failure of any power supply.....	14
4.9 Manual reset control.....	14
4.10 Standstill detection and monitoring.....	14
4.11 Machine moving parts speed monitoring.....	14
4.12 Time delay.....	14
4.13 Teleservice.....	14
5 Safety requirements and measures for protection against mechanical hazards	14
5.1 Stability.....	14
5.2 Risk of break-up during operation.....	15
5.3 Tool and tool fixing design.....	15
5.3.1 General.....	15
5.3.2 Spindle locking.....	15
5.3.3 Circular saw blade fixing device.....	15
5.3.4 Flange dimension for circular saw blades.....	15
5.3.5 Spindle rings.....	15
5.4 Braking.....	16
5.4.1 Braking of tools.....	16
5.4.2 Maximum run-down time.....	16
5.4.3 Brake release.....	16
5.5 Safeguards.....	16
5.5.1 Fixed guards.....	16
5.5.2 Interlocking moveable guards.....	16
5.5.3 Hold-to-run control.....	17
5.5.4 Two-hand control.....	17
5.5.5 Electro-sensitive protective equipment (ESPE).....	17
5.5.6 Pressure-sensitive protective equipment (PSPE).....	17

5.5.7	Enabling control	17
5.6	Prevention of access to hazardous moving parts	17
5.6.1	Guarding of tools installed inside the integral enclosure	17
5.6.2	Guarding of external milling units	17
5.6.3	Guarding of sanding belts	18
5.6.4	Guarding of the edge banding zone	18
5.6.5	Access between machine halves on double-end machines	18
5.6.6	Access to hazard points through the slot between chain beam and top pressure beam	19
5.6.7	Guarding of drives	20
5.6.8	Safeguarding of the feed mechanisms	20
5.6.9	Safeguarding of machine half movement on double-end machines	23
5.7	Impact hazard	26
5.8	Clamping devices	26
5.9	Measures against ejection	26
5.9.1	General	26
5.9.2	Guards materials and characteristics	27
5.9.3	Devices to minimize ejection of rigid edges	27
5.9.4	Height adjustments of feed mechanism	28
5.10	Workpiece supports and guides	28
5.10.1	General	28
5.10.2	Additional workpiece support at the outfeed	28
5.10.3	Transversal infeed device	29
5.10.4	Automatic panel returner	29
6	Safety requirements and measures for protection against other hazards	30
6.1	Fire	30
6.2	Noise	31
6.2.1	Noise reduction at the design stage	31
6.2.2	Noise emission measurement and declaration	31
6.3	Emission of chips and dust	31
6.4	Electricity	31
6.5	Ergonomics and handling	31
6.6	Lighting	31
6.7	Pneumatics	31
6.8	Hydraulics	31
6.9	Electromagnetic compatibility	31
6.10	Laser	32
6.11	Static electricity	32
6.12	Errors of fitting	32
6.13	Isolation	32
6.14	Maintenance	32
6.15	Relevant but not significant hazards	32
6.16	Extreme temperatures	32
6.17	Substances	33
6.18	Artificial optical radiation	33
7	Information for use	33
7.1	Warning devices	33
7.2	Marking	33
7.2.1	General	33
7.2.2	Additional markings	33
7.3	Instruction handbook	34
7.3.1	General	34
7.3.2	Additional information	34
	Annex A (informative) List of significant hazards	36
	Annex B (informative) Performance level required	38
	Annex C (normative) Stability test	40

Annex D (normative) Test for braking function	41
Annex E (normative) Impact test for guards	42
Annex F (normative) Noise test code	43
Bibliography	48

iTeh STANDARD PREVIEW
(standards.iteh.ai)

[ISO 19085-17:2021](https://standards.iteh.ai/catalog/standards/sist/33348b15-dee0-441a-9bb4-ecb804af5bdd/iso-19085-17-2021)

<https://standards.iteh.ai/catalog/standards/sist/33348b15-dee0-441a-9bb4-ecb804af5bdd/iso-19085-17-2021>

Foreword

ISO (the International Organization for Standardization) is a worldwide federation of national standards bodies (ISO member bodies). The work of preparing International Standards is normally carried out through ISO technical committees. Each member body interested in a subject for which a technical committee has been established has the right to be represented on that committee. International organizations, governmental and non-governmental, in liaison with ISO, also take part in the work. ISO collaborates closely with the International Electrotechnical Commission (IEC) on all matters of electrotechnical standardization.

The procedures used to develop this document and those intended for its further maintenance are described in the ISO/IEC Directives, Part 1. In particular, the different approval criteria needed for the different types of ISO documents should be noted. This document was drafted in accordance with the editorial rules of the ISO/IEC Directives, Part 2 (see www.iso.org/directives).

Attention is drawn to the possibility that some of the elements of this document may be the subject of patent rights. ISO shall not be held responsible for identifying any or all such patent rights. Details of any patent rights identified during the development of the document will be in the Introduction and/or on the ISO list of patent declarations received (see www.iso.org/patents).

Any trade name used in this document is information given for the convenience of users and does not constitute an endorsement.

For an explanation of the voluntary nature of standards, the meaning of ISO specific terms and expressions related to conformity assessment, as well as information about ISO's adherence to the World Trade Organization (WTO) principles in the Technical Barriers to Trade (TBT) see www.iso.org/iso/foreword.html.

This document was prepared by Technical Committee ISO/TC 39, *Machine tools*, Subcommittee SC 4, *Woodworking machines*, in collaboration with the European Committee for Standardization (CEN) Technical Committee CEN/TC 142, *Woodworking machines – Safety*, in accordance with the Agreement on technical cooperation between ISO and CEN (Vienna Agreement).

This first edition cancels and replaces ISO 18217:2015.

This document is intended to be used in conjunction with ISO 19085-1:2021, which gives requirements common to different machine types.

Any feedback or questions on this document should be directed to the user's national standards body. A complete listing of these bodies can be found at www.iso.org/members.html.

A list of all parts in the ISO 19085 series can be found on the ISO website.

Introduction

The ISO 19085 series provides technical safety requirements for the design and construction of woodworking machinery. It concerns designers, manufacturers, suppliers and importers of the machines specified in the Scope. It also includes a list of informative items to be provided to the user by the manufacturer.

This document is a type-C standard as stated in ISO 12100.

This document is of relevance, in particular, for the following stakeholder groups representing the market players with regard to machinery safety:

- machine manufacturers (small, medium and large enterprises);
- health and safety bodies (regulators, accident prevention organisations, market surveillance etc.)

Others can be affected by the level of machinery safety achieved with the means of the document by the above-mentioned stakeholder groups:

- machine users/employers (small, medium and large enterprises);
- machine users/employees (e.g. trade unions, organizations for people with special needs);
- service providers, e. g. for maintenance (small, medium and large enterprises);
- consumers (in case of machinery intended for use by consumers).

The above-mentioned stakeholder groups have been given the possibility to participate at the drafting process of this document.

The machinery concerned and the extent to which hazards, hazardous situations or hazardous events are covered are indicated in the Scope.

When requirements of this type-C standard are different from those which are stated in type-A or type-B standards, the requirements of this type-C standard take precedence over the requirements of the other standards for machines that have been designed and built according to the requirements of this type-C standard.

The full set of requirements for a particular type of woodworking machine are those given in the part of ISO 19085 applicable to that type, together with the relevant requirements from ISO 19085-1, to the extent specified in the Scope of the applicable part of the ISO 19085 series.

As far as possible, the safety requirements of parts of the ISO 19085 series refer to the relevant subclauses of ISO 19085-1. Each part contains replacements and additions to the common requirements given in ISO 19085-1.

[Clauses 1 to 3](#) are specific to each part and, therefore, replace ISO 19085-1:2021, Clauses 1 to 3.

For [Clauses 4 to 7](#) and the annexes, ISO 19085-1:2021, Clauses 4 to 7 and Annexes, each subclause can be:

- confirmed as a whole;
- confirmed with additions;
- excluded in total; or
- replaced with specific text.

This is indicated by one of the following possible statements:

- “ISO 19085-1:2021, [subclause/Annex], applies”;

ISO 19085-17:2021(E)

- “ISO 19085-1:2021, [subclause/Annex], applies with the following additions.” or “ISO 19085-1:2021, [subclause/Annex], applies with the following additions, subdivided into further specific subclauses.”;
- “ISO 19085-1:2021, [subclause/Annex], does not apply.”;
- “ISO 19085-1:2021, [subclause/Annex], is replaced by the following text.” or “ISO 19085-1:2021, [subclause/Annex], is replaced by the following text, subdivided into further specific subclauses.”.

Other subclauses and annexes specific to this document are indicated by the introductory sentence: “Subclause/Annex specific to this document.”.

iTeh STANDARD PREVIEW (standards.iteh.ai)

[ISO 19085-17:2021](https://standards.iteh.ai/catalog/standards/sist/33348b15-dee0-441a-9bb4-ecb804af5bdd/iso-19085-17-2021)

<https://standards.iteh.ai/catalog/standards/sist/33348b15-dee0-441a-9bb4-ecb804af5bdd/iso-19085-17-2021>

Woodworking machines — Safety —

Part 17: Edge banding machines fed by chains

1 Scope

This document gives the safety requirements and measures for edge banding machines fed by chains or belts, with manual loading and unloading and maximum workpiece height capacity of 100 mm, capable of continuous production use, hereinafter referred to as “machines”.

It deals with all significant hazards, hazardous situations and events, listed in [Annex A](#), relevant to the machines, when operated, adjusted and maintained as intended and under the conditions foreseen by the manufacturer; reasonably foreseeable misuse has been considered too. Also, transport, assembly, dismantling, disabling and scrapping phases are taken into account.

The machines are designed to process in one pass one end (single-end machine) or both ends (double-end machine) of panels of:

- materials with similar physical characteristics to wood (see ISO 19085-1:2021, 3.2), even with a core sheet of aluminium light alloy;
- gypsum plaster boards.

Edges to be applied by the machine can be made of:

- paper;
- melamine;
- plastic;
- composite materials;
- aluminium;
- light alloy;
- veneer;
- solid wood.

It is also applicable to machines fitted with one or more of the following devices/working units, whose hazards have been dealt with:

- hot air banding unit;
- laser banding unit;
- infrared banding unit;
- dynamic processing units;
- sanding belt units;
- milling unit installed out of the integral enclosure at the panel side on single-end machines;
- milling unit installed out of the integral enclosure between machines halves of double-end machines;

ISO 19085-17:2021(E)

- additional fixed or movable workpiece support along the feed;
- additional infeed workpiece support;
- additional outfeed workpiece support;
- in-feed device for transversal loading of panels in single-end machines;
- intermediate workpiece support in double-end machines;
- automatic panel returner in single-end machines;
- automatic tool changing;
- quick tool changing system;
- automatic multiple edges infeed device;
- workpiece heaters.

This document does not deal with any hazards relating to:

- a) systems for loading and unloading of the workpiece to a single machine other than automatic panel returner and infeed and outfeed workpiece supports (e.g. robots);
- b) the combination of a single machine being used with other machines (as part of a line);
- c) workpiece dividing unit installed out of the integral enclosure and/or whose tools protrude out of the integral enclosure;
- d) plasma banding unit.

It is not applicable to machines intended for use in potentially explosive atmosphere nor manufactured before the date of its publication.

2 Normative references

The following documents are referred to in the text in such a way that some or all of their content constitutes requirements of this document. For dated references, only the edition cited applies. For undated references, the latest edition of the referenced document (including any amendments) applies.

ISO 11553-1:2005, *Safety of machinery — Laser processing machines — Part 1: General safety requirements*

ISO 12100:2010, *Safety of machinery — General principles for design — Risk assessment and risk reduction*

ISO 13732-1:2006, *Ergonomics of the thermal environment — Methods for the assessment of human responses to contact with surfaces — Part 1: Hot surfaces*

ISO 13849-1:2015, *Safety of machinery — Safety-related parts of control systems — Part 1: General principles for design*

ISO 13856-2:2013, *Safety of machinery — Pressure-sensitive protective devices — Part 2: General principles for design and testing of pressure-sensitive edges and pressure-sensitive bars*

ISO 19085-1:2021, *Woodworking machines — Safety — Part-1: common requirements*

IEC 61310-1:2007, *Safety of machinery — Indication, marking and actuation — Part 1: Requirements for visual, acoustic and tactile signals*

IEC 60825-1:2014, *Safety of laser products — Part 1: Equipment classification and requirements*

EN 847-1:2017, *Tools for woodworking — Safety requirements — Part 1: Milling tools, circular saw blades*

EN 847-2:2017, *Tools for woodworking — Safety requirements — Part 2: Requirements for the shank of shank mounted milling tools/circular saw blades*

3 Terms and definitions

For the purposes of this document, the terms and definitions given in ISO 12100:2010, ISO 13849-1:2015, ISO 19085-1:2021 and the following apply.

ISO and IEC maintain terminological databases for use in standardization at the following addresses:

- ISO Online browsing platform: available at <https://www.iso.org/obp>
- IEC Electropedia: available at <http://www.electropedia.org/>

3.1

edge banding machine

machine designed for banding in one pass the edge on one side of the workpiece (single-end edge banding machine) or on both sides of the workpiece (double-end edge banding machine), consisting of an edge banding zone with various units (e.g. for heating, banding, pressing of the edge, etc.), of a zone for additional operations (e.g. for snipping, trimming, milling, sanding, polishing, chamfering, etc.) and in addition a sizing/profiling zone that can precede the edge banding zone.

Note 1 to entry: The main parts of a single-end machine and a double-end machine and their terminology are illustrated in [Figures 1](#) and [2](#) respectively.

Note 2 to entry: The glue can be applied to the edge or to the workpiece side.

Note 3 to entry: Workpiece feeding can be by chains or by feeding belts.

ISO 19085-17:2021

<https://standards.iteh.ai/catalog/standards/sist/33348b15-dee0-441a-9bb4-ecb804af5bdd/iso-19085-17-2021>

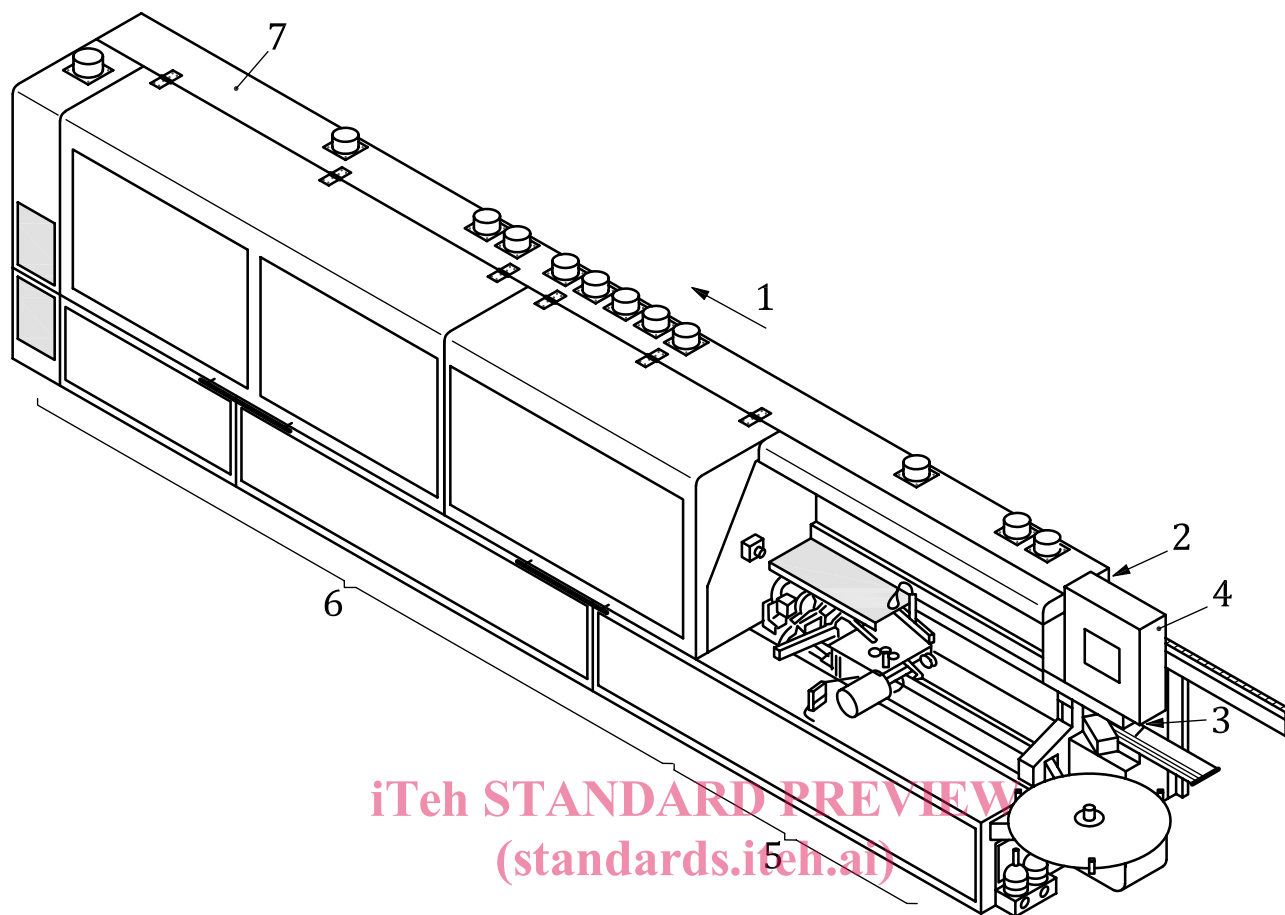

iTeh STANDARD PREVIEW
(standards.itech.ai)

ISO 19085-17:2021

<https://standards.itech.ai/catalog/standards/sist/33348b15-dee0-441a-9bb4-ecb804af5bdd/iso-19085-17-2021>

Key

- | | | | |
|---|-------------------|---|---------------------------|
| 1 | feed direction | 5 | edge banding zone |
| 2 | top pressure beam | 6 | additional operation zone |
| 3 | chain/belt beam | 7 | integral enclosure |
| 4 | controls | | |

Figure 1 — Example of a single-end machine

3.2 machine half

<double-end machines> part of a machine consisting of a frame, chain/belt beam, top pressure beam and working units

Note 1 to entry: the two machine halves process the two opposite sides of the workpiece in the same pass. One or both machine halves are capable of being moved to accept workpieces of different dimensions.

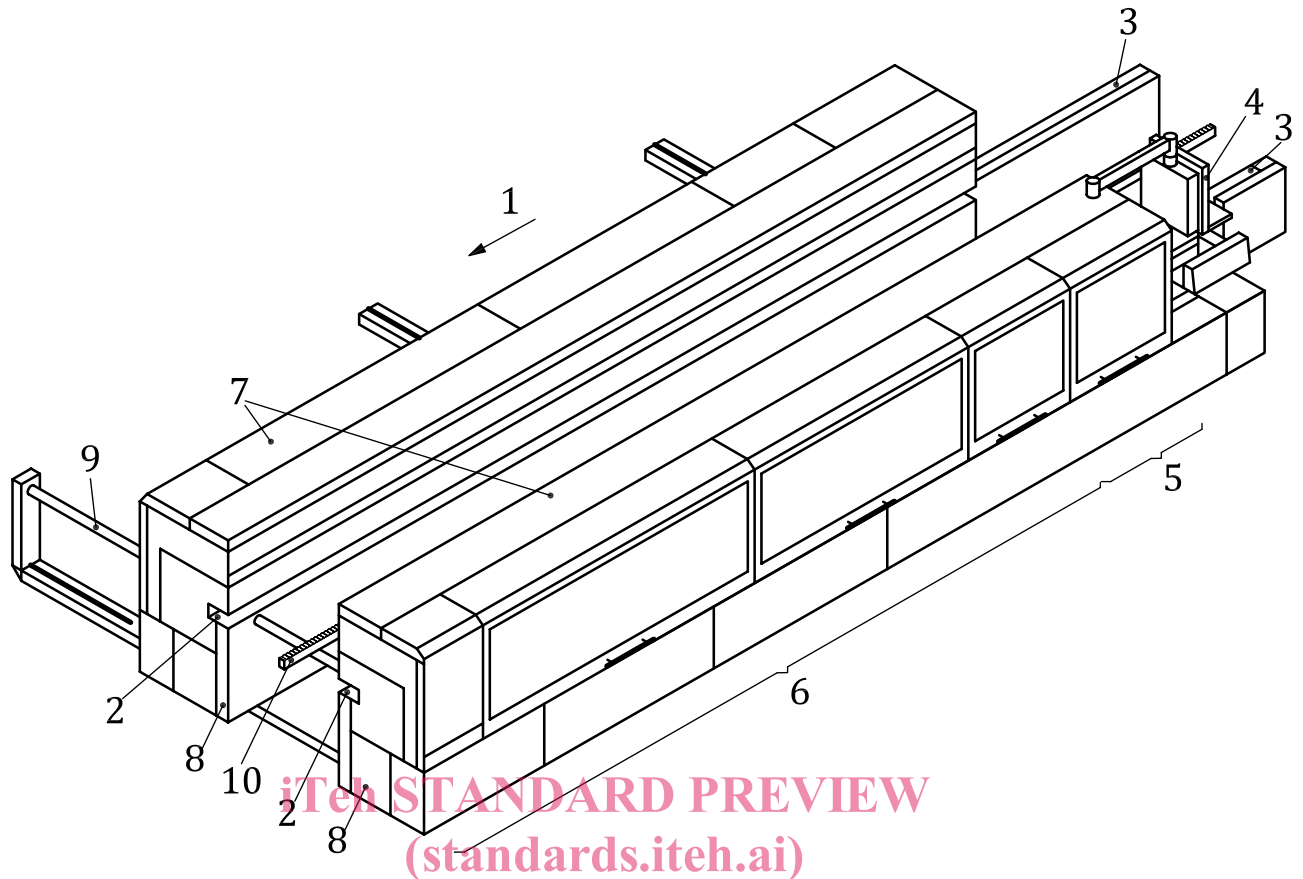
**Key**

- | | | | |
|---|-------------------|----|--------------------------------|
| 1 | feed direction | 6 | additional operation zone |
| 2 | top pressure beam | 7 | integral enclosure |
| 3 | chain beam | 8 | machine halves |
| 4 | controls | 9 | feed cross drive shaft |
| 5 | edge banding zone | 10 | intermediate workpiece support |

Figure 2 — Example of a double-end machine

3.3 integral enclosure

guarding designed to fit close to the single-end machine or to each *machine half* (3.2) of double-end machines, to provide a measure of sound attenuation and where certain setting adjustments can be available outside the enclosure

3.4 gluing unit

unit for the adhesion of the edge to the panel by any technology

Note 1 to entry: *Hot melt banding unit* (3.5), *hot air banding unit* (3.6), *laser banding unit* (3.7), *infrared banding unit* (3.8) are kinds of gluing unit, and can be alternative or additional to each other in a machine.

3.5 hot melt banding unit

unit using hot melt glue for edge banding

3.6 hot air banding unit

unit heating the edge using high temperature compressed air for edge banding, without addition of glue

**3.7
laser banding unit**

unit heating the edge using laser radiation for edge banding, without addition of glue

**3.8
infrared banding unit**

unit heating the edge using infrared radiation for edge banding, without addition of glue

**3.9
workpiece heater**

device to pre-heat the panel before the edge is banded to the panel

Note 1 to entry: Workpiece heater is different from the units heating the edge for adhesion activation

**3.10
dynamic processing unit**

unit which moves with the workpiece during processing and returns to its starting position ready for the following (succeeding) workpiece

Note 1 to entry: An example of dynamic processing unit is shown in [Figure 3](#).

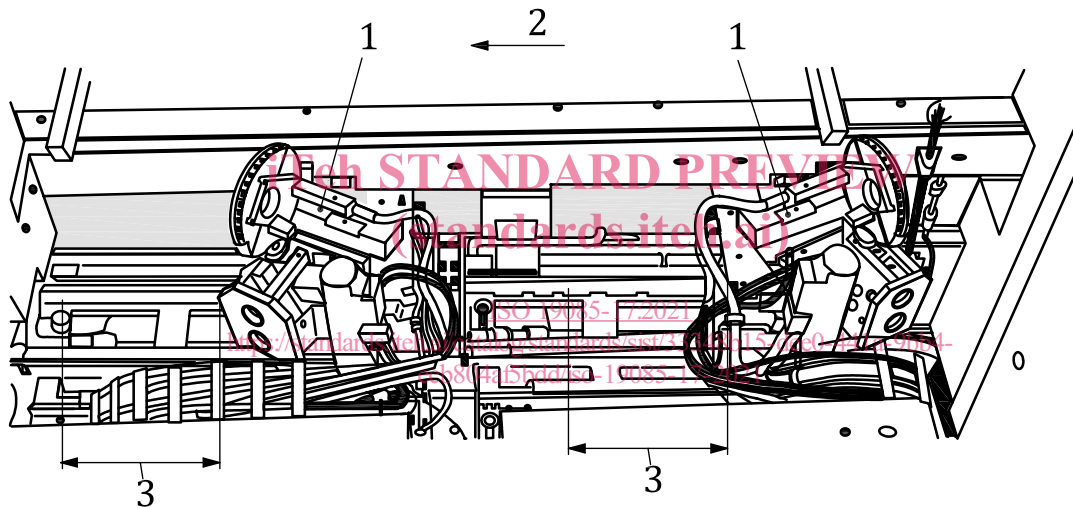

Key

- 1 dynamic processing unit (e.g. sniper saw)
- 2 feed direction
- 3 movement zone

Figure 3 — Example of a dynamic processing unit

**3.11
external milling unit**

<single-end machines> milling unit installed out of the integral enclosure at the panel side for grooving along the lower surface of the processed panel or for grooving/milling along the panel side opposite to the banded one

Note 1 to entry: An example of external milling unit for grooving along the lower surface of the processed panel or along the panel side opposite to the banded one in single-end machines is shown in [Figure 4](#).

Note 2 to entry: An example of external milling unit for milling along the panel side opposite to the banded one in single-end machines is shown in [Figure 5](#).

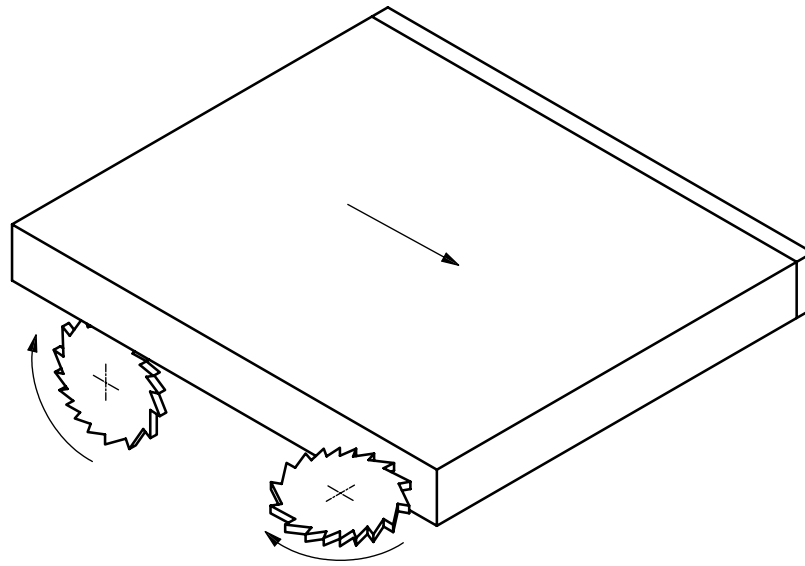
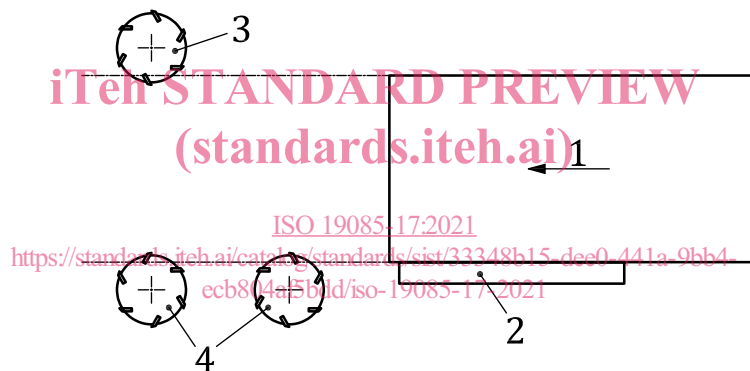

Figure 4 — Example of unit for grooving along the lower surface of the processed panel or along the panel side opposite to the banded one



Key

- | | | | |
|---|-----------------|---|-------------------------------------|
| 1 | feed direction | 3 | external milling unit |
| 2 | workpiece guide | 4 | tools inside the integral enclosure |

Figure 5 — Example of unit for milling along the panel side opposite to the banded one

3.12

external milling unit

<double-end machines> milling unit installed out of the integral enclosure between machines halves for grooving along the lower surface of the processed panel

Note 1 to entry: An example of external milling unit in double-end machines is shown in [Figure 8](#), key 7.

3.13

additional workpiece support

workpiece support with the purpose of facilitating manipulation and manual loading or unloading of panels

Note 1 to entry: An additional workpiece support can be installed at the infeed or at the outfeed side of the machine.