

DRAFT INTERNATIONAL STANDARD

ISO/DIS 9854-1

ISO/TC 138/SC 5

Secretariat: NEN

Voting begins on:
2022-06-24

Voting terminates on:
2022-09-16

Thermoplastics pipes for the transport of fluids — Determination of Charpy impact properties —

Part 1: General test method

Partie 1: Méthode générale d'essai

ICS: 23.040.20; 23.040.20

iTeh STANDARD PREVIEW
(standards.iteh.ai)

[ISO/FDIS 9854-1](https://standards.iteh.ai/catalog/standards/sist/f6b6b114-5c52-41b1-afe0-6b36a9364fb8/iso-fdis-9854-1)

<https://standards.iteh.ai/catalog/standards/sist/f6b6b114-5c52-41b1-afe0-6b36a9364fb8/iso-fdis-9854-1>

THIS DOCUMENT IS A DRAFT CIRCULATED FOR COMMENT AND APPROVAL. IT IS THEREFORE SUBJECT TO CHANGE AND MAY NOT BE REFERRED TO AS AN INTERNATIONAL STANDARD UNTIL PUBLISHED AS SUCH.

IN ADDITION TO THEIR EVALUATION AS BEING ACCEPTABLE FOR INDUSTRIAL, TECHNOLOGICAL, COMMERCIAL AND USER PURPOSES, DRAFT INTERNATIONAL STANDARDS MAY ON OCCASION HAVE TO BE CONSIDERED IN THE LIGHT OF THEIR POTENTIAL TO BECOME STANDARDS TO WHICH REFERENCE MAY BE MADE IN NATIONAL REGULATIONS.

RECIPIENTS OF THIS DRAFT ARE INVITED TO SUBMIT, WITH THEIR COMMENTS, NOTIFICATION OF ANY RELEVANT PATENT RIGHTS OF WHICH THEY ARE AWARE AND TO PROVIDE SUPPORTING DOCUMENTATION.

This document is circulated as received from the committee secretariat.



Reference number
ISO/DIS 9854-1:2022(E)

© ISO 2022

iTeh STANDARD PREVIEW
(standards.iteh.ai)

ISO/FDIS 9854-1

<https://standards.iteh.ai/catalog/standards/sist/f6b6b114-5c52-41b1-afe0-6b36a9364fb8/iso-fdis-9854-1>



COPYRIGHT PROTECTED DOCUMENT

© ISO 2022

All rights reserved. Unless otherwise specified, or required in the context of its implementation, no part of this publication may be reproduced or utilized otherwise in any form or by any means, electronic or mechanical, including photocopying, or posting on the internet or an intranet, without prior written permission. Permission can be requested from either ISO at the address below or ISO's member body in the country of the requester.

ISO copyright office
CP 401 • Ch. de Blandonnet 8
CH-1214 Vernier, Geneva
Phone: +41 22 749 01 11
Email: copyright@iso.org
Website: www.iso.org

Published in Switzerland

Contents

	Page
Foreword.....	iv
Introduction.....	vi
1 Scope.....	1
2 Normative references.....	1
3 Terms and definitions.....	2
4 Principle.....	2
5 Apparatus.....	3
5.1 Pendulum impact-testing machine.....	3
5.2 Micrometres and gauges.....	3
5.3 Ambient equipment.....	3
5.4 Temperature measuring equipment.....	3
6 Test specimen.....	4
6.1 Preparation.....	4
6.2 Cutting and dimensions.....	4
6.2.1 Method A.....	4
6.2.2 Method B.....	6
6.3 Number.....	9
7 Conditioning.....	9
8 Procedure.....	10
8.1 General.....	10
8.2 Method A.....	10
8.3 Method B.....	11
9 Expression of results.....	11
9.1 Method A.....	11
9.2 Method B.....	11
10 Test report.....	12

Foreword

ISO (the International Organization for Standardization) is a worldwide federation of national standards bodies (ISO member bodies). The work of preparing International Standards is normally carried out through ISO technical committees. Each member body interested in a subject for which a technical committee has been established has the right to be represented on that committee. International organizations, governmental and non-governmental, in liaison with ISO, also take part in the work. ISO collaborates closely with the International Electrotechnical Commission (IEC) on all matters of electrotechnical standardization.

The procedures used to develop this document and those intended for its further maintenance are described in the ISO/IEC Directives, Part 1. In particular, the different approval criteria needed for the different types of ISO documents should be noted. This document was drafted in accordance with the editorial rules of the ISO/IEC Directives, Part 2 (see www.iso.org/directives).

Attention is drawn to the possibility that some of the elements of this document may be the subject of patent rights. ISO shall not be held responsible for identifying any or all such patent rights. Details of any patent rights identified during the development of the document will be in the Introduction and/or on the ISO list of patent declarations received (see www.iso.org/patents).

Any trade name used in this document is information given for the convenience of users and does not constitute an endorsement.

For an explanation of the voluntary nature of standards, the meaning of ISO specific terms and expressions related to conformity assessment, as well as information about ISO's adherence to the World Trade Organization (WTO) principles in the Technical Barriers to Trade (TBT), see www.iso.org/iso/foreword.html.

This document was prepared by Technical Committee ISO/TC 138, *Plastics pipes, fittings and valves for the transport of fluids*, Subcommittee SC 5, *General properties of pipes, fittings and valves of plastic materials and their accessories — Test methods and basic specifications*.

This second edition cancels and replaces the first edition (ISO 9854-1:1994), which has been technically revised.

The main changes are as follows:

- The title has been revised to Thermoplastics pipes for the transport of fluids — Determination of Charpy impact properties — Part 1: General test method.
- [Clause 1](#), method A has been modified and method B has been added.
- [Clause 2](#), ISO 13802 has been added.
- [Clause 3](#), terms and definitions have been added.
- [Clause 4](#), principle has been rewritten.
- [5.1](#) has been revised to suit notched specimens.
- [5.3](#) has been added specifying the micrometres and gauges for measuring the dimensions of specimens.
- [5.4](#), temperature measuring equipment has been added.
- [Figure 3](#) has been modified extending the support area to stabilize the bigger specimens.
- Notched specimens have been added in [Table 1](#).
- [6.2.1](#) has been revised giving a method of unnotched specimens preparation.
- [6.2.2](#) has been added to cover the case of notched specimens.

- [Figure 4](#), [Figure 5](#), [Figure 6](#), [Figure 7](#) and [Figure 8](#) have been added.
- [Clause 7](#) has been revised specifying the period of time prior to testing after the production of the pipe and the requirements of liquid bath and air bath.
- [8.1](#) has been added giving the procedure of test of notched and unnotched specimens.
- [9.2](#) has been added giving the expression of results of notched specimens.
- [10 i\)](#) has been revised giving the type(s) of failure observed and the number and the percentage of each type of failures.
- [10 j\)](#) has been added to cover the case of notched specimens.

A list of all parts in the ISO 9854 series can be found on the ISO website.

Any feedback or questions on this document should be directed to the user's national standards body. A complete listing of these bodies can be found at www.iso.org/members.html.

iTeh STANDARD PREVIEW
(standards.iteh.ai)

[ISO/FDIS 9854-1](#)

<https://standards.iteh.ai/catalog/standards/sist/f6b6b114-5c52-41b1-afe0-6b36a9364fb8/iso-fdis-9854-1>

Introduction

The International Organization for Standardization (ISO) draws attention to the fact that it is claimed that compliance with this document may involve the use of a patent.

ISO takes no position concerning the evidence, validity and scope of this patent right.

The holder of this patent right has assured ISO that he/she is willing to negotiate licences under reasonable and non-discriminatory terms and conditions with applicants throughout the world. In this respect, the statement of the holder of this patent right is registered with ISO. Information may be obtained from the patent database available at www.iso.org/patents.

Attention is drawn to the possibility that some of the elements of this document may be the subject of patent rights other than those in the patent database. ISO shall not be held responsible for identifying any or all such patent rights.

iTeh STANDARD PREVIEW
(standards.iteh.ai)

ISO/FDIS 9854-1

<https://standards.iteh.ai/catalog/standards/sist/f6b6b114-5c52-41b1-afe0-6b36a9364fb8/iso-fdis-9854-1>

Thermoplastics pipes for the transport of fluids — Determination of Charpy impact properties —

Part 1: General test method

1 Scope

This document specifies the general test method to be used for the determination of the impact properties of unnotched and notched specimens cut from thermoplastics pipes for the transport of fluids.

- Method A: unnotched method, for unnotched specimens cut from thermoplastics pipes for the transport of fluids.
- Method B: notched method, for specimens cut from thermoplastics pipes for the transport of fluids, into which a notch has been machined.

NOTE 1 The use of method A or method B is determined by the relevant product standards.

It is not intended to be a reference test method for the determination of the impact strength of pipes.

NOTE 2 ISO 3127, relating to the determination of the impact strength of pipes by means of a falling mass, is the reference method. However, this part of ISO 9854 can be used for scientific research, materials testing or the examination of pipe when it is not possible to take measurements in accordance with the reference method.

This document may be applied to either isolated batches or continuous production of pipe and the test can be carried out at -20 °C , 0 °C or 23 °C , depending on the pipe material and/or size.

For the test parameters, i.e. impact energy, specimen dimensions, type and span of the specimen supports and type of specimen, to be used to determine the pendulum impact strength of pipes, the specifications for specific materials are given in ISO/DIS 9854-2, as appropriate.

NOTE 3 Data obtained from specimens of different dimensions are not directly comparable.

2 Normative references

The following documents are referred to in the text in such a way that some or all of their content constitutes requirements of this document. For dated references, only the edition cited applies. For undated references, the latest edition of the referenced document (including any amendments) applies.

ISO 179-1, *Plastics — Determination of Charpy impact properties — Part 1: Non-instrumented impact test*

ISO 2818, *Plastics — Preparation of test specimens by machining*

ISO/DIS 9854-2¹⁾, *Thermoplastics pipes for the transport of fluids — Determination of Charpy impact properties — Part 2: Test conditions for pipes of various materials*

ISO 13802, *Plastics — Verification of pendulum impact-testing machines — Charpy, Izod and tensile impact-testing*

1) Under preparation. (Stage at the time of ISO/DIS 9854-2:2022.)

3 Terms and definitions

For the purposes of this document, the terms and definitions given in ISO 179-1 and the following apply.

ISO and IEC maintain terminological databases for use in standardization at the following addresses:

- ISO Online browsing platform: available at <https://www.iso.org/obp>
- IEC Electropedia: available at <https://www.electropedia.org/>

3.1 Charpy notched impact strength

α_{cN}
impact energy absorbed in breaking a notched specimen, referred to the original cross-sectional area of the specimen at the notch

Note 1 to entry: It is expressed in kilojoules per square metre (kJ/m²).

3.2 nominal outside diameter

d_n
specified outside diameter, assigned to a nominal size DN/OD

Note 1 to entry: It is expressed in millimetres (mm).

3.3 nominal wall thickness

e_n
numerical designation of the wall thickness of a component, which is a convenient round number, approximately equal to the manufacturing dimension

Note 1 to entry: It is expressed in millimetres (mm).

3.4 remaining thickness

h_N
thickness at notch tip of test pieces which have been notched

Note 1 to entry: It is expressed in millimetres (mm).

3.5 span

L
the distance between the lines of contact of the specimen with the supports

Note 1 to entry: It is expressed in millimetres (mm).

4 Principle

A short length of pipe, or a strip specimen machined therefrom, is conditioned at a selected temperature, T_c and then supported near its ends as a horizontal beam. The specimen is impacted by a single blow of a striker at a high, nominally constant, velocity, with the line of impact midway between the supports.

In the case of edgewise/flatwise impact with notched specimens, the line of impact is directly opposite the notch.

5 Apparatus

5.1 Pendulum impact-testing machine

5.1.1 The principles, characteristics and verification of suitable test machine shall conform to ISO 13802.

5.1.2 When applicable, test machine may consist of a temperature control device capable of maintaining test temperature as specified.

5.1.3 Pendulum impact-testing machine shall be with the following characteristics:

5.1.3.1 Method A

- a) Velocity at impact 3,8 m/s;
- b) Pendulums providing maximum impact energies of 15 J and 50 J respectively, with a tapered tip of $30^\circ \pm 1^\circ$ and a tip radius of $2,0 \text{ mm} \pm 0,5 \text{ mm}$;
- c) Specimen supports in accordance with [Figure 1](#) and [Figure 2](#) for longitudinal plane specimens;
- d) Specimen supports in accordance with [Figure 3](#) for circumferential plane specimens. Fixed point of anvils and specimen supports should be adjustable in the horizontal plane parallel to the plane of the swing of the pendulum. The top of the convex specimen should be in line with the centre of percussion at the moment of impact.

5.1.3.2 Method B

- a) Velocity at impact 2,9 m/s;
- b) Check that the impact machine is able to perform the test at the specified velocity of impact and that the absorbed energy is within the correct range, which shall be between 10 % and 80 % of the total available energy from the pendulum at impact, with a tapered tip of $30^\circ \pm 1^\circ$ and a tip radius of $2,0 \text{ mm} \pm 0,5 \text{ mm}$. If more than one of the pendulums conforms to these requirements, the pendulum having the highest energy shall be used;
- c) Specimen supports in accordance with [Figure 4](#) for longitudinal plane notched specimens.

5.2 Micrometres and gauges

Micrometres and gauges capable of measuring the essential dimensions of test specimens to an accuracy of 0,02 mm are required. For measuring the dimension h_N of notched specimens, the micrometre shall have a spindle with a measuring tip having a suitable profile to fit the type of the notch.

NOTE A method of determining the notch tip radius using a CCD microscope is provided by ISO 179-1.

5.3 Ambient equipment

Comprising either a thermostatically controlled enclosure or a liquid bath capable of bringing the specimens to the specified temperature, T_c (see [Clause 7](#)). When a liquid bath is used, the liquid used shall not have a detrimental effect on the physical properties of the specimens.

5.4 Temperature measuring equipment

Temperature measuring equipment, capable of checking conformity to the specified temperature with an accuracy to within $\pm 0,5^\circ\text{C}$.

6 Test specimen

6.1 Preparation

The specimens shall be cut from pipe, in accordance with the procedure of ISO 2818 and with 6.2.1 or 6.2.2, as appropriate, so that any surface which comes into contact with the anvil, comprising the specimen supports, or with the pendulum at the moment of impact, is smooth and free from burrs. Chamfering shall be avoided during specimen preparation (see Figure 2).

6.2 Cutting and dimensions

6.2.1 Method A

6.2.1.1 Each specimen for pipes up to 25 mm nominal outside diameter shall consist of a length of pipe $100 \text{ mm} \pm 2 \text{ mm}$ long, see Table 1 specimen type 1.

6.2.1.2 Each specimen for pipes greater than or equal to 25 mm and less than 75 mm nominal outside diameter shall be cut from pipe in the longitudinal direction and shall conform to the dimensions of one of the types given in Table 1, see Table 1 specimen type 2 or type 3.

6.2.1.3 Each specimen for pipes greater than or equal to 75 mm and less than 160 mm nominal outside diameter shall be cut from pipe in the longitudinal and circumferential directions and shall conform to the dimensions of one of the types given in Table 1. See Table 1 specimen type 2 or type 3 for longitudinal cut specimens, and specimen type 4 for circumferential cut specimens.

6.2.1.4 Each specimen for pipes greater than or equal to 160 mm nominal outside diameter shall be cut from pipe in the longitudinal and circumferential directions and shall conform to the dimensions of one of the types given in Table 1. See Table 1 specimen type 2 or type 3 for longitudinal cut specimens, and specimen type 4 or type 5 for circumferential cut specimens.

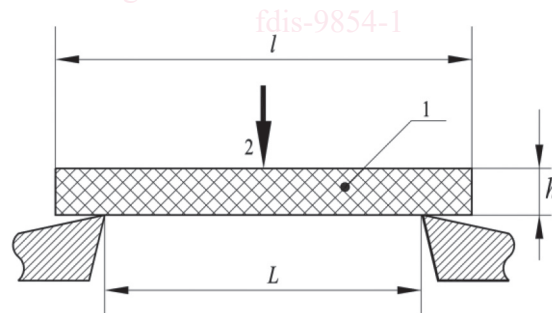

Key

- 1 specimen
- 2 direction of blow
- h specimen thickness, it coincides with the outside diameter
- l specimen length, (100 ± 2) mm
- L span, $(70 \pm 0,5)$ mm

Figure 1 — Supports for specimen type 1