



SLOVENSKI STANDARD
oSIST prEN 1459-1:2023
01-junij-2023

Nadomešča:
SIST EN 1459-1:2018+A1:2020

Vozila za talni transport - Terenska vozila - Varnostne zahteve in preverjanje - 1. del: Vozila z mehanizmom za dviganje s spremenljivim dosegom

Rough-terrain trucks - Safety requirements and verification - Part 1: Variable-reach trucks

Geländegängige Stapler - Sicherheitstechnische Anforderungen und Verifizierung - Teil 1: Stapler mit veränderlicher Reichweite

Chariots tout-terrain - Prescriptions de sécurité et vérification - Partie 1 : Chariots à portée variable

Ta slovenski standard je istoveten z: prEN 1459-1

ICS:

53.060 Industrijski tovornjaki Industrial trucks

oSIST prEN 1459-1:2023 **en,fr,de**

EUROPEAN STANDARD
NORME EUROPÉENNE
EUROPÄISCHE NORM

DRAFT
prEN 1459-1

April 2023

ICS 53.060

Will supersede EN 1459-1:2017+A1:2020

English Version

Rough-terrain trucks - Safety requirements and verification - Part 1: Variable-reach trucks

Chariots tout-terrain - Prescriptions de sécurité et vérification - Partie 1 : Chariots à portée variable

Geländegängige Stapler - Sicherheitstechnische Anforderungen und Verifizierung - Teil 1: Stapler mit veränderlicher Reichweite

This draft European Standard is submitted to CEN members for enquiry. It has been drawn up by the Technical Committee CEN/TC 150.

If this draft becomes a European Standard, CEN members are bound to comply with the CEN/CENELEC Internal Regulations which stipulate the conditions for giving this European Standard the status of a national standard without any alteration.

This draft European Standard was established by CEN in three official versions (English, French, German). A version in any other language made by translation under the responsibility of a CEN member into its own language and notified to the CEN-CENELEC Management Centre has the same status as the official versions.

CEN members are the national standards bodies of Austria, Belgium, Bulgaria, Croatia, Cyprus, Czech Republic, Denmark, Estonia, Finland, France, Germany, Greece, Hungary, Iceland, Ireland, Italy, Latvia, Lithuania, Luxembourg, Malta, Netherlands, Norway, Poland, Portugal, Republic of North Macedonia, Romania, Serbia, Slovakia, Slovenia, Spain, Sweden, Switzerland, Türkiye and United Kingdom.

Recipients of this draft are invited to submit, with their comments, notification of any relevant patent rights of which they are aware and to provide supporting documentation.

Warning : This document is not a European Standard. It is distributed for review and comments. It is subject to change without notice and shall not be referred to as a European Standard.



EUROPEAN COMMITTEE FOR STANDARDIZATION
COMITÉ EUROPÉEN DE NORMALISATION
EUROPÄISCHES KOMITEE FÜR NORMUNG

CEN-CENELEC Management Centre: Rue de la Science 23, B-1040 Brussels

Contents	Page
European foreword	5
Introduction	6
1 Scope.....	7
2 Normative references.....	8
3 Terms and definitions	11
4 Safety requirements and/or protective measures	16
4.1 General.....	16
4.1.1 Introduction.....	16
4.1.2 Sharp edges and acute angles.....	16
4.1.3 Stored energy components.....	16
4.2 Starting/stopping of engine and moving machine	16
4.2.1 Unauthorized starting.....	16
4.2.2 Stopping system	16
4.2.3 Unintended movement	16
4.2.4 Uncontrolled motion	16
4.2.5 Powered travel movement	17
4.2.6 Non-activation of the parking brake.....	17
4.3 Brakes	17
4.3.1 General.....	17
4.3.2 Failure of energy supply.....	17
4.3.3 Holding performance	18
4.4 Electrical and electronic systems.....	18
4.4.1 General.....	18
4.4.2 Safety related parts of control systems.....	19
4.4.3 Degree of protection	19
4.4.4 Identification of wiring.....	19
4.4.5 Protection against electric shock.....	19
4.4.6 Batteries	20
4.5 Controls at the normal operating position	20
4.5.1 General.....	20
4.5.2 Differential locking	20
4.5.3 Steering controls	21
4.5.4 Load handling controls	23
4.5.5 Multi-function controls.....	23
4.5.6 Stabilizing device control.....	24
4.5.7 Sway/levelling control.....	24
4.5.8 Axle oscillation locking.....	24
4.6 Remote control	24
4.7 Power systems and accessories.....	25
4.7.1 Exhaust system	25
4.7.2 Cooling system	25
4.7.3 Tanks and pressure vessels	25
4.8 Stabilizing devices	26
4.9 Design requirements for maintenance purposes	28

4.9.1	General	28
4.9.2	Boom support device.....	28
4.9.3	Tiltable cab support device.....	28
4.10	Systems for lifting, tilting and reaching.....	29
4.10.1	Chains and wire ropes.....	29
4.10.2	Hydraulic system	30
4.10.3	Maximum load lowering speed.....	31
4.10.4	Limitation of stroke	31
4.10.5	Fork arms	31
4.10.6	Attachment interface.....	32
4.11	Operator's station.....	32
4.11.1	General requirements.....	32
4.11.2	Operator's manual storage.....	32
4.11.3	Pipes and hoses	32
4.11.4	Operator's station.....	32
4.11.5	Operator's seat	35
4.11.6	Control panels, and symbols on displays.....	37
4.12	Operator access.....	37
4.12.1	General requirements.....	37
4.12.2	Operator's station openings	37
4.13	Protective measures and devices	38
4.13.1	Hot parts	38
4.13.2	Protection against crushing, shearing and trapping	38
4.13.3	Guards.....	38
4.13.4	Engine compartment.....	38
4.13.5	Fenders.....	39
4.13.6	ROPS and FOPS	39
4.13.7	Audible warning devices.....	39
4.14	Stability requirements.....	39
4.15	Visibility.....	40
4.16	Lighting.....	40
4.17	Fire protection.....	40
4.17.1	Fire resistance	40
4.17.2	Fire extinguisher.....	40
4.18	Retrieval, transportation and lifting	40
4.18.1	General	40
4.18.2	Retrieval.....	40
4.18.3	Tying-down	40
4.18.4	Lifting.....	41
4.19	Noise.....	41
4.19.1	Noise emission reduction	41
4.19.2	Emission sound pressure level at the operator's station.....	41
4.20	Electromagnetic radiation.....	42
4.20.1	Non-ionising radiation.....	42
4.20.2	External radiation	42
5	Verification of requirements and safety measures.....	42
5.1	General	42
5.2	Functional verification	42
5.3	Structural verification	42
5.3.1	Test loads.....	42
5.3.2	Static test	43
5.3.3	Dynamic tests.....	43

prEN 1459-1:2023 (E)

5.4	Load holding verification.....	44
6	Information for use	44
6.1	General.....	44
6.2	Graphical symbols and warning.....	44
6.2.1	Safety Signs and graphical symbols.....	44
6.2.2	Graphical symbol of lift points	44
6.2.3	Graphical symbol of tie-down points.....	44
6.2.4	Graphical symbol of retrieval points	45
6.2.5	Graphical symbol for pneumatic tyre inflation pressures.....	45
6.2.6	Graphical symbol for fuel filling points	46
6.2.7	Graphical symbol for hydraulic fluid filling points	46
6.2.8	Graphical symbols for stored energy components.....	47
6.2.9	Graphical symbol for brake fluid filling points.....	48
6.2.10	Graphical symbol for battery disconnection	48
6.2.11	Warnings.....	49
6.3	Instruction handbook.....	49
6.3.1	General.....	49
6.3.2	Operating and maintenance instructions	50
6.4	Marking	53
6.5	Load chart.....	54
6.5.1	Trucks with load carrying attachments.....	54
6.5.2	Trucks with non-load carrying attachments	56
	Annex A (informative) List of significant hazards.....	57
	Annex B (informative) Consistency of motions.....	63
	Annex C (normative) Rules for the construction and layout of pedals.....	64
C.1	Definitions	64
C.1.1	pedal.....	64
C.1.2	service brake pedal.....	64
C.1.3	clutch pedal.....	64
C.1.4	inching pedal	64
C.1.5	accelerator pedal	64
C.2	Requirements.....	64
C.2.1	General.....	64
C.2.2	Service brake pedal.....	64
C.2.3	Clutch pedal	65
C.2.4	Accelerator pedal.....	65
C.2.5	Inching pedal	65
C.3	Design and manufacture	65
	Annex ZA (informative) Relationship between this European Standard and the essential requirements of Directive 2006/42/EC aimed to be covered	67
	Bibliography	72

European foreword

This document (prEN 1459-1:2023) has been prepared by Technical Committee CEN/TC 150 “Industrial Trucks - Safety”, the secretariat of which is held by BSI.

This document is currently submitted to the CEN Enquiry.

This document will supersede EN 1459-1:2017+A1:2020.

In comparison with the previous edition, the following technical modifications have been made:

- addition of an alternative calculation method for chains and wire ropes;
- requirements for trucks not fitted with an enclosed cab;
- update of normative references;
- other minor changes, mainly editorial clarifications of existing requirements.

EN 1459 consists of the following parts, under the general title Rough-terrain trucks — Safety requirements and verification:

- Part 1: Variable-reach trucks
- Part 2: Slewing variable-reach trucks
- Part 3: Interface between the variable-reach truck and the work platform
- Part 4: Additional requirements for variable-reach trucks handling suspended loads
- Part 5: Attachment interface
- Part 6: Application of EN ISO 13849-1 to slewing and non-slewing variable-reach rough-terrain truck (technical report)
- Part 8: Variable-reach tractors
- Part 9: Variable-reach trucks equipped with work platforms having a frontguard that can be opened

This document has been prepared under a Standardization Request given to CEN by the European Commission and the European Free Trade Association, and supports essential requirements of EU Directive(s) / Regulation(s).

For relationship with EU Directive(s) / Regulation(s), see informative Annex ZA, which is an integral part of this document.

prEN 1459-1:2023 (E)**Introduction**

This document covers general safety requirements and the means for verification of these requirements for rough-terrain variable-reach trucks.

All quantities are in SI units, and this includes metric units.

Considering the technical improvements to the previous version of EN 1459, a transition period of 12 months is permitted after the date of publication, such that manufacturers can develop their products sufficiently to meet the requirements of this document.

This document is a type C standard as stated in EN ISO 12100:2010.

This document is of relevance, in particular, for the following stakeholder groups representing the market players with regard to machinery safety:

- machine manufacturers (small, medium and large enterprises);
- health and safety bodies (regulators, accident prevention organizations, market surveillance etc.).

Others can be affected by the level of machinery safety achieved with the means of the document by the above-mentioned stakeholder groups:

- machine users/employers (small, medium and large enterprises);
- machine users/employees (e.g. trade unions, organizations for people with special needs);
- service providers, e.g. for maintenance (small, medium and large enterprises);
- consumers (in case of machinery intended for use by consumers).

The above-mentioned stakeholder groups have been given the possibility to participate at the drafting process of this document.

The machinery concerned and the extent to which hazards, hazardous situations or hazardous events are covered are indicated in the scope of this document.

When provisions of this type C standard are different from those which are stated in type A or B standards, the provisions of this type C standard take precedence over the provisions of the other standards, for machines that have been designed and built according to the provisions of this type C standard.

1 Scope

This document specifies the safety requirements of self-propelled rough-terrain variable-reach trucks (hereafter referred to as trucks), intended to handle loads, equipped with a telescopic lifting means (pivoted boom), on which a load handling device (e.g. carriage and fork arms) is fitted.

For the purpose of this document, rough-terrain variable-reach trucks are designed to transport, lift and place loads and can be driven on unimproved terrain.

Fork arms are considered to be part of the truck. Trucks can also be equipped with a variety of attachments (e.g. bale spikes, mowers, sweepers).

This document deals with all the significant hazards, hazardous situations and events relevant to the trucks when they are used as intended and under conditions of misuse which are reasonably foreseeable by the manufacturer (see Annex A).

This document does not apply to:

- slewing rough-terrain variable-reach trucks covered by EN 1459-2:2015+A1:2018;
- rough-terrain variable-reach tractors;
- industrial variable reach trucks covered by EN ISO 3691-2:2016;
- lorry-mounted variable-reach trucks covered by ISO 20297-1:2017;
- variable-reach trucks fitted with tilting or elevating operator position;
- mobile cranes covered by EN 13000:2010+A1:2014;
- machines designed primarily for earth moving, even if their buckets and blades are replaced with forks (see EN 474 series);
- trucks designed primarily with variable length load suspension elements (e.g. chain, ropes) from which the load may swing freely in all directions;
- trucks fitted with personnel work platforms, designed to move persons to elevated working positions;
- trucks designed primarily for container handling;
- trucks on tracks;
- trucks with articulated chassis;
- attachments.

This document does not address sound power level.

This document does not address hazards linked to:

- operation of the truck from a position other than the normal operating position or the remote control;
- hybrid power systems;
- gas power system;

prEN 1459-1:2023 (E)

- gasoline engine system;
- battery power system.

This document does not address hazards which may occur:

- a) when handling suspended loads which may swing freely (additional requirements are given in EN 1459-4: 2020);
- b) when using trucks on public roads;
- c) when operating in potentially explosive atmospheres;
- d) when operating underground;
- e) when towing trailers;
- f) when fitted with a personnel work platform (additional requirements are given in EN 1459 3:2015 and EN 1459-9:2021);
- g) when using system capable of controlling the speed of the truck as set by the operator (cruise-control).

This document does not provide a method of calculation for fatigue and strength of material.

This document is not applicable to trucks manufactured before the date of its publication.

2 Normative references

The following documents are referred to in the text in such a way that some or all of their content constitutes requirements of this document. For dated references, only the edition cited applies. For undated references, the latest edition of the referenced document (including any amendments) applies.

EN 1459-5:2020,¹ *Rough-terrain trucks - Safety requirements and verification - Part 5: Attachment interface*

EN 12053:2001+A1:2008, *Safety of industrial trucks - Test methods for measuring noise emissions*

EN 12895:2015+A1:2019, *Industrial trucks - Electromagnetic compatibility*

EN 13059:2002+A1:2008, *Safety of industrial trucks - Test methods for measuring vibration*

EN 15000:2008, *Safety of industrial trucks - Self propelled variable reach trucks - Specification, performance and test requirements for longitudinal load moment indicators and longitudinal load moment limiters*

EN 17314:2020, *Industrial trucks - Specifications and test methods - Operator restraint systems other than lap-type seat belts*

EN 15830:2012, *Rough-terrain variable reach trucks - Visibility - Test methods and verification*

EN 60529:1991,² *Degrees of protection provided by enclosures (IP Code) (IEC 60529:1989)*

¹ This document is impacted by EN 1459-5:2020/prA1:202x.

² This document is impacted by the amendments EN 60529:1991/A1:2000 and EN 60529:1991/A2:2013.

- EN IEC 62061:2021, *Safety of machinery - Functional safety of safety-related electrical, electronic and programmable electronic control systems (IEC 62061:2021)*
- EN ISO 2860:2008, *Earth-moving machinery - Minimum access dimensions (ISO 2860:1992)*
- EN ISO 2867:2011, *Earth-moving machinery - Access systems (ISO 2867:2011)*
- EN ISO 3449:2008, *Earth-moving machinery - Falling-object protective structures - Laboratory tests and performance requirements (ISO 3449:2005)*
- EN ISO 3457:2008, *Earth-moving machinery - Guards - Definitions and requirements (ISO 3457:2003)*
- EN ISO 3471:2008, *Earth-moving machinery - Roll-over protective structures - Laboratory tests and performance requirements (ISO 3471:2008)*
- EN ISO 4413:2010, *Hydraulic fluid power - General rules and safety requirements for systems and their components (ISO 4413:2010)*
- EN ISO 5353:1998, *Earth-moving machinery, and tractors and machinery for agriculture and forestry - Seat index point (ISO 5353:1995)*
- EN ISO 6682:2008, *Earth-moving machinery - Zones of comfort and reach for controls (ISO 6682:1986, including Amd 1:1989)*
- EN ISO 6683:2008, *Earth-moving machinery - Seat belts and seat belt anchorages - Performance requirements and tests (ISO 6683:2005)*
- EN ISO 7096:2020, *Earth-moving machinery - Laboratory evaluation of operator seat vibration (ISO 7096:2020)*
- EN ISO 11688-1:2009, *Acoustics - Recommended practice for the design of low-noise machinery and equipment - Part 1: Planning (ISO/TR 11688-1:1995)*
- EN ISO 12100:2010, *Safety of machinery - General principles for design - Risk assessment and risk reduction (ISO 12100:2010)*
- EN ISO 13766-1:2018, *Earth-moving and building construction machinery - Electromagnetic compatibility (EMC) of machines with internal electrical power supply - Part 1: General EMC requirements under typical electromagnetic environmental conditions (ISO 13766-1:2018)*
- EN ISO 13849-1:2015, *Safety of machinery - Safety-related parts of control systems - Part 1: General principles for design (ISO 13849-1:2015)*
- EN ISO 13850:2015, *Safety of machinery - Emergency stop function - Principles for design (ISO 13850:2015)*
- EN ISO 13857:2019, *Safety of machinery - Safety distances to prevent hazard zones being reached by upper and lower limbs (ISO 13857:2019)*
- ISO 2330:2002, *Fork-lift trucks — Fork arms — Technical characteristics and testing*
- ISO 3795:1989, *Road vehicles, and tractors and machinery for agriculture and forestry — Determination of burning behaviour of interior materials*
- ISO 5053-1:2020, *Industrial trucks — Vocabulary — Part 1: Types of industrial trucks*

prEN 1459-1:2023 (E)

ISO 6011:2003, *Earth-moving machinery — Visual display of machine operation*

ISO 6292:2020, *Powered industrial trucks and tractors — Brake performance and component strength*

ISO 7000:2019, *Graphical symbols for use on equipment — Registered symbols*

ISO 9533:2010, *Earth-moving machinery — Machine-mounted audible travel alarms and forward horns — Test methods and performance criteria*

ISO 10263-2:2009, *Earth-moving machinery — Operator enclosure environment — Part 2: Air filter element test method*

ISO 10263-3:2009, *Earth-moving machinery — Operator enclosure environment — Part 3: Pressurization test method*

ISO 10263-4:2009, *Earth-moving machinery — Operator enclosure environment — Part 4: Heating, ventilating and air conditioning (HVAC) test method and performance*

ISO 11112:1995,³ *Earth-moving machinery - Operator's seat - Dimensions and requirements*

ISO 12508:1994, *Earth-moving machinery — Operator station and maintenance areas — Bluntness of edges*

ISO 12509:2023, *Earth-moving machinery - Lighting, signalling and marking lights, and reflex-reflector devices*

ISO 13284:2022, *Fork-lift trucks — Fork-arm extensions and telescopic fork arms — Technical characteristics and strength requirements*

ISO 13333:1994, *Earth-moving machinery — Dumper body support and operator's cab tilt support devices*

ISO 15817:2012, *Earth-moving machinery — Safety requirements for remote operator control systems*

ISO 15818:2017, *Earth-moving machinery — Lifting and tying-down attachment points — Performance requirements*

ISO 15870:2000, *Powered industrial trucks — Safety signs and hazard pictorials — General principles*

ISO 16528-1:2007, *Boilers and pressure vessels — Part 1: Performance requirements*

ISO 16528-2:2007, *Boilers and pressure vessels — Part 2: Procedures for fulfilling the requirements of ISO 16528-1*

ISO 21507:2010, *Earth-moving machinery — Performance requirements for non-metallic fuel tanks*

ISO 22915-10:2008, *Industrial trucks — Verification of stability — Part 10: Additional stability test for trucks operating in the special condition of stacking with load laterally displaced by powered devices*

ISO 22915-14:2010, *Industrial trucks — Verification of stability — Part 14: Rough-terrain variable-reach trucks*

³ Document impacted by ISO 11112:1995/A1:2001.

ISO 22915-20:2008, *Industrial trucks — Verification of stability — Part 20: Additional stability test for trucks operating in the special condition of offset load, offset by utilization*

3 Terms and definitions

For the purposes of this document, the terms and definitions given in EN ISO 12100:2010, ISO 5053-1:2020 and the following apply.

ISO and IEC maintain terminological databases for use in standardization at the following addresses:

- IEC Electropedia: available at <http://www.electropedia.org/>
- ISO Online browsing platform: available at <http://www.iso.org/obp>

3.1

rough-terrain variable-reach truck

variable-reach truck intended primarily for operation on unimproved natural terrain and on the disturbed terrain of, for example, construction site

[SOURCE: ISO 5053-1:2020, 3.21]

3.2

variable-reach truck

lift truck fitted with one or more articulated arms, telescopic or not, non-slewing or having a slewing movement of not more than 5° either side of the longitudinal axis of the truck used for stacking loads

[SOURCE: ISO 5053-1:2020, 3.20]

Note 1 to entry: See Figure 1.

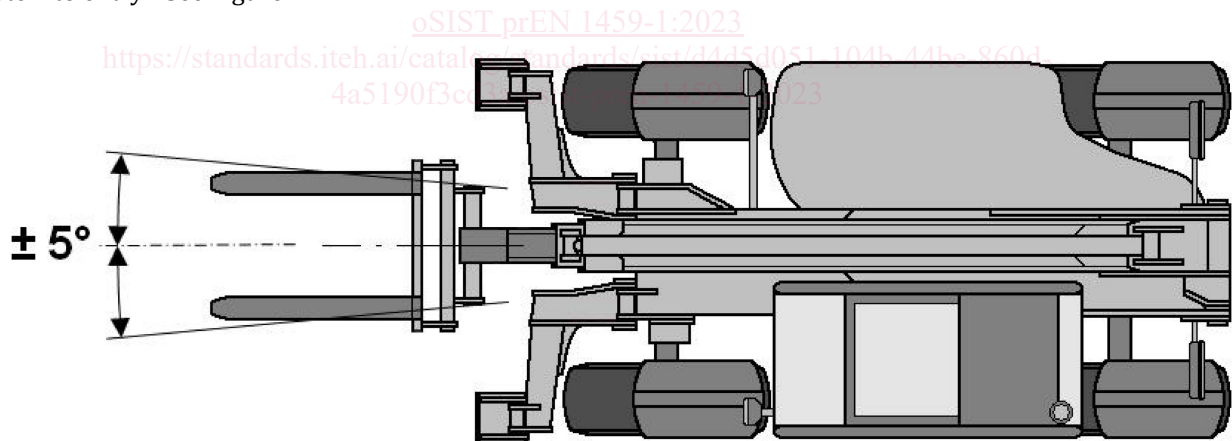

Figure 1 — Variable-reach truck

3.3

compact truck

truck having a maximum height in normal travel mode of 2 150 mm and at least one of the following conditions:

- a maximum operating mass of 7 000 kg;
- a maximum width in normal travel mode of 2 000 mm

Note 1 to entry: These dimensions do not include equipment such as working lights, mirrors, etc.

prEN 1459-1:2023 (E)**3.4****actual capacity****Q**

maximum load, established by the manufacturer based on components strength and truck stability, that the truck can carry, lift and stack to a specified height, at a specified standard load centre distance and reach, in normal operating conditions

Note 1 to entry: The actual capacity depends on the configuration of the truck in terms of such variables as:

- lift height;
- reach of the boom;
- standard load centre distance;
- load handling device (fork arms or attachment fitted);
- stabilizing devices.

Note 2 to entry: This actual capacity defines the load handling ability of the particular truck as equipped. Additional actual capacity ratings with removable attachments may also be established where permitted by the appropriate stability test or by calculation verified by empirical data.

3.5**rated capacity****Q1**

maximum load permitted by the manufacturer at the standard load centre distance (D) that the truck is capable of lifting and transporting on fork arms in normal conditions with the boom fully retracted

3.6**reach****d**

distance between two vertical parallel planes, one plane tangent to the front of the outside diameter of the front tyres, the other plane described by the vertical projection of the centre-of-gravity of the load to the ground

Note 1 to entry: The centre-of-gravity of the load (G) is defined in Table 1.

Note 2 to entry: See Figure 2 for examples of reach.

Note 3 to entry: For practical matters, d can be measured referring to point g, being g the vertical projection of the centre-of-gravity (G) of the load onto the plane of the top surface of the fork arms.

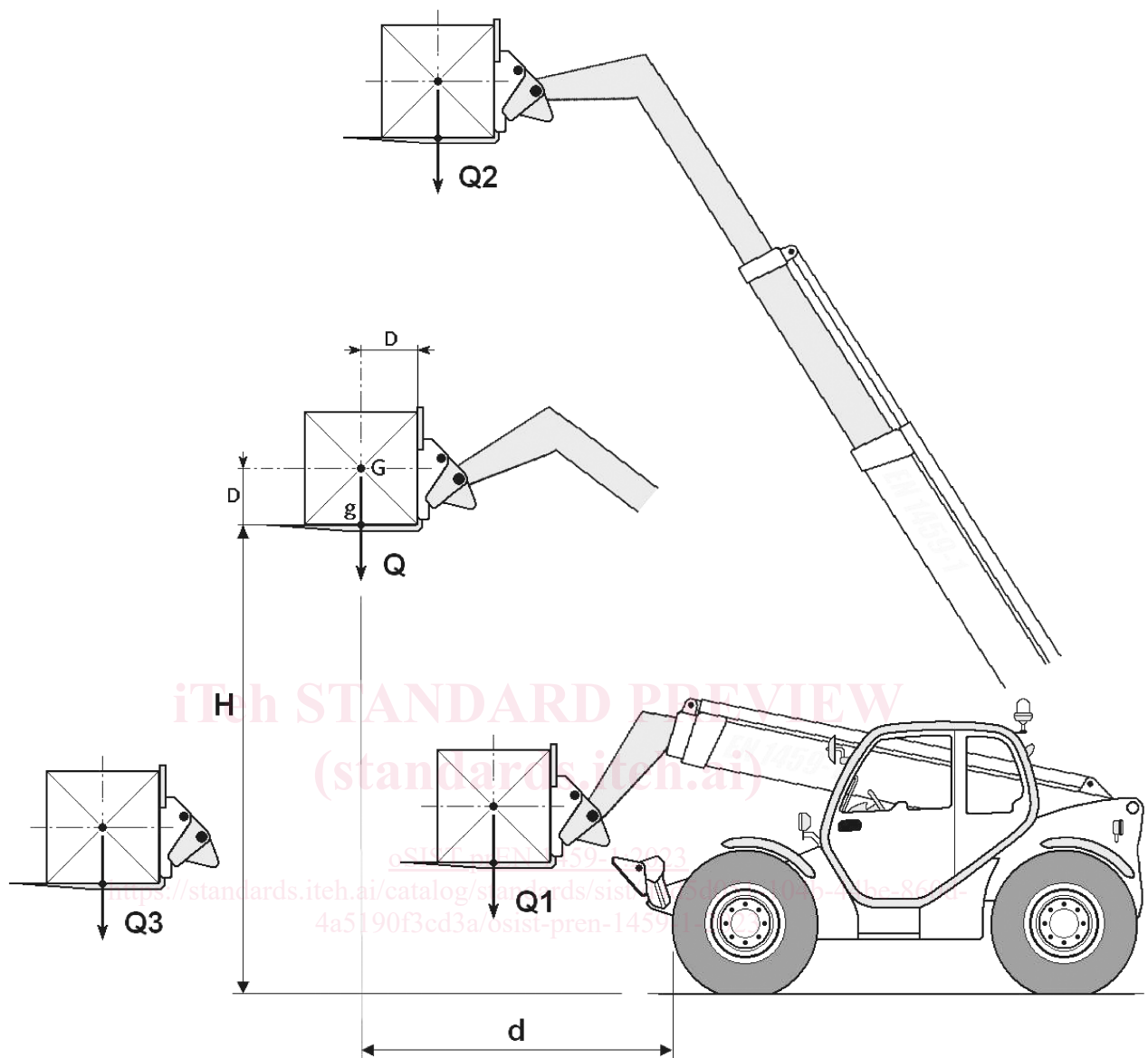
**Key**

- d Reach
- D standard load centre distance
- G centre of gravity of the load
- g the vertical projection of the centre-of-gravity (G) of the load onto the plane of the top surface of the fork arms
- H height of the load
- Q actual capacity
- Q1 rated capacity
- Q2 actual capacity at maximum height or elevation
- Q3 actual capacity at maximum reach

Figure 2 — Parameters for the designation of the actual capacity of the truck with fork