



Designation: D291 – 07<sup>ε1</sup>

## Standard Test Method for Cubic Foot Weight of Crushed Bituminous Coal<sup>1</sup>

This standard is issued under the fixed designation D291; the number immediately following the designation indicates the year of original adoption or, in the case of revision, the year of last revision. A number in parentheses indicates the year of last reapproval. A superscript epsilon ( $\epsilon$ ) indicates an editorial change since the last revision or reapproval.

<sup>ε1</sup> NOTE—11.1.1 was editorially corrected in January 2011.

### 1. Scope

1.1 This test method covers two procedures for determining the cubic foot weight of crushed coal less than 1½ in. (37 mm) in size, such as is charged into coke ovens, as follows:

1.1.1 *Procedure A*—The cone procedure for determining an uncompacted weight per cubic foot (cubic metre).

1.1.2 *Procedure B*—The dropped-coal procedure for determining a compacted weight per cubic foot (cubic metre), comparable to actual bulk densities attained in coke ovens.

1.2 This test method is not applicable to the testing of powdered coal as used in boiler plants, nor to the determination of weights per cubic foot of coal in storage piles.

1.3 The values stated in inch-pound units are to be regarded as standard. The values given in parentheses are mathematical conversions to SI units that are provided for information only and are not considered standard. Mass may be expressed in metric values.

1.4 *This standard does not purport to address all of the safety concerns, if any, associated with its use. It is the responsibility of the user of this standard to establish appropriate safety and health practices and determine the applicability of regulatory limitations prior to use.*

### 2. Referenced Documents

2.1 *ASTM Standards:*<sup>2</sup>

D440 Test Method of Drop Shatter Test for Coal

D2234/D2234M Practice for Collection of a Gross Sample of Coal

D3038 Test Method for Drop Shatter Test for Coke

D3302 Test Method for Total Moisture in Coal

D4749 Test Method for Performing the Sieve Analysis of

### Coal and Designating Coal Size

### 3. Significance and Use

3.1 This test method concerns the compaction of crushed coal to determine either its compacted or uncompacted weight, for purposes such as charging coke ovens.

#### PROCEDURE A—CONE PROCEDURE FOR UNCOMPACTED CUBIC FOOT (CUBIC METRE) WEIGHT

### 4. Apparatus

4.1 *Measuring Box*, of rigid construction, having inside dimensions of 12.0 by 12.0 by 12.0 in. (305 by 305 by 305 mm), and a volume of  $1728 \pm 5$  in.<sup>3</sup> ( $0.0283$  m<sup>3</sup>  $\pm$  82 cm<sup>3</sup>). The exact volume of the box shall be determined by water calibration.

4.2 *Cone*, conforming to Fig. 1 for filling the box. This cone shall be 2 ft 0 in. (610 mm) high and 1 ft 8 in. (508 mm) in inside diameter at the top, with a circular opening 4½ in. (114 mm) in diameter at the bottom. A slide valve consisting of a sliding-plate shutter and its supports shall be welded to the bottom of the cone in such a manner that the valve may be opened and closed with ease by removing or inserting the shutter in its supporting slides. The cone shall be supported in a tripod frame having a circular opening at the top of about 1 ft 6 in. (457 mm) in diameter. This frame shall support the cone so that the top-side of the shutter shall be 1 ft 10 in. (559 mm) from the inside bottom surface of the box. (See Fig. 1.)

4.3 *Leveling Bar*, a steel strip 2 ft 6 in. long by 1½ in. wide (762 by 38 mm) and approximately ⅜ in. (5 mm) thick.

4.4 *Scales*, platform, capable of weighing up to 200 lb (100 kg) and sensitive to 0.1 lb (0.05 kg).

### 5. Sampling

5.1 *Gross Sample*—For collecting gross samples of crushed bituminous coal, the procedure described in Sections 7 and 8 of Practice D2234/D2234M shall apply. During the period of collecting the gross sample, the increments of the sample shall be stored in a waterproof container with a tightly fitting cover in order to prevent the loss of moisture. The minimum number

<sup>1</sup> This test method is under the jurisdiction of ASTM Committee D05 on Coal and Coke and is the direct responsibility of Subcommittee D05.07 on Physical Characteristics of Coal.

Current edition approved Oct. 1, 2007. Published October 2007. Originally approved in 1927. Last previous edition approved in 2002 as D291 – 86 (2002). DOI: 10.1520/D0291-07E01.

<sup>2</sup> For referenced ASTM standards, visit the ASTM website, www.astm.org, or contact ASTM Customer Service at service@astm.org. For *Annual Book of ASTM Standards* volume information, refer to the standard's Document Summary page on the ASTM website.

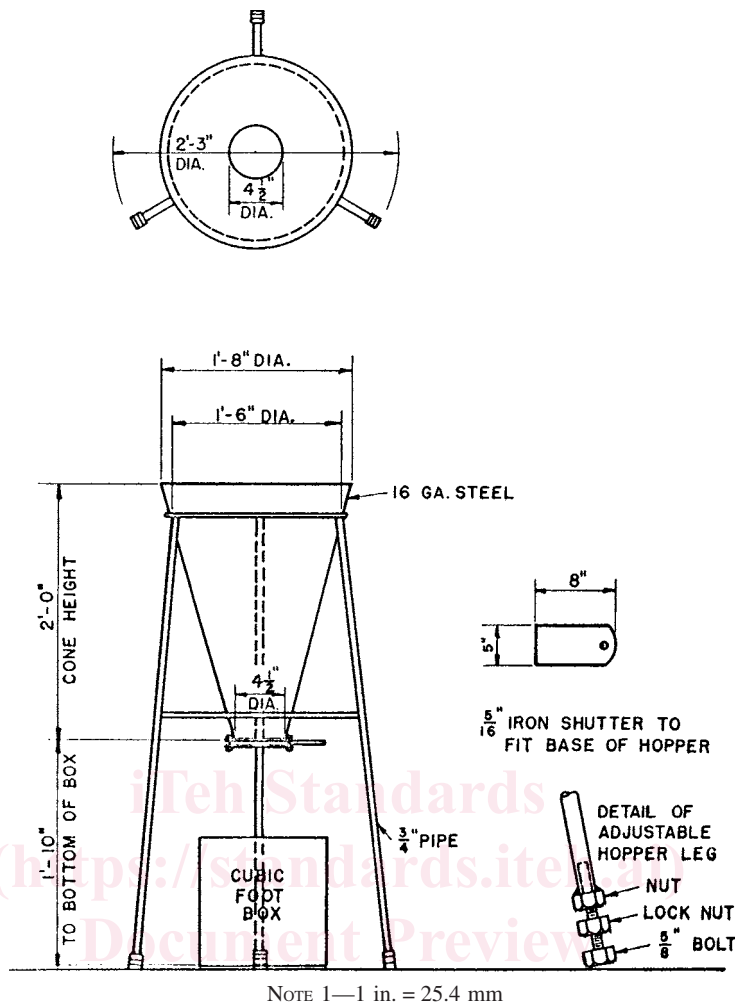

FIG. 1 Apparatus for Cone Procedure

and weights of increments collected shall be in accordance with Table 2 of Practice D2234/D2234M. The minimum gross weight of the sample shall be 300 lb (136 kg).

5.2 *Laboratory Sample*—The gross sample of coal shall be thoroughly mixed and subdivided, without crushing, into four 75-lb (34-kg) portions. This operation shall be done as quickly as possible to avoid loss of moisture, and the cubic foot (cubic metre) weight shall be determined immediately. If this determination cannot be made immediately, the samples shall be kept in waterproof containers with tightly fitting covers until the time for making the determination.

## 6. Procedure

6.1 Before filling the cone hopper, level it in its tripod on a solid floor. Pour the prepared sample into a pile on the floor and carefully flatten it to about 4 in. (100 mm) in thickness. Avoid pounding of the pile with the back of the shovel. Take successive shovelfuls from uniformly distributed points in the pile, and allow them to slide gently from the shovel into the hopper at different peripheral points. This will prevent segre-

gation and packing while the hopper is being filled. Place about 75 lb (34 kg) of coal in the hopper.

6.2 Center the previously weighed cubic foot (cubic metre) box under the valve of the cone. Then remove the valve shutter completely, allowing all of the coal to flow into the box and overflow the edges. Loosen wet coal, not flowing freely from the hopper, by gently thrusting downward through the coal to the valve with the leveling bar.

6.3 After filling the box, carefully level off the excess coal above the box edge by means of the leveling bar, and place the box on the platform scale and weigh it to the nearest 0.1 lb (0.05 kg). Avoid jarring or shifting of the filled box until all excess coal is leveled off. Record the difference in weight between the filled and empty box to the nearest 0.1 lb (0.05 kg) as the uncompacted cubic foot weight.

NOTE 1—Aside from the character of the coal itself, moisture content and size distribution of the coal are the two main factors which affect the cubic foot weight. A moisture determination and sieve analysis of the coal should be reported along with the cubic foot weight for proper interpretation of the cubic foot weight. For directions for making these