



Designation: D1857-04 Designation: D1857/D1857M - 04 (Reapproved 2010)

## Standard Test Method for Fusibility of Coal and Coke Ash<sup>1</sup>

This standard is issued under the fixed designation D1857/D1857M; the number immediately following the designation indicates the year of original adoption or, in the case of revision, the year of last revision. A number in parentheses indicates the year of last reapproval. A superscript epsilon ( $\epsilon$ ) indicates an editorial change since the last revision or reapproval.

*This standard has been approved for use by agencies of the Department of Defense.*

### 1. Scope

1.1 This test method covers the observation of the temperatures at which triangular pyramids (cones) prepared from coal and coke ash attain and pass through certain defined stages of fusing and flow when heated at a specified rate in controlled, mildly reducing, and where desired, oxidizing atmospheres.

1.2 The test method is empirical, and strict observance of the requirements and conditions is necessary to obtain reproducible temperatures and enable different laboratories to obtain concordant results.

~~1.3 The values stated in SI units are to be regarded as the standard. The values given in parentheses are for information only.~~

1.3 The values stated in either SI units or inch-pound units are to be regarded separately as standard. The values stated in each system may not be exact equivalents; therefore, each system shall be used independently of the other. Combining values from the two systems may result in non-conformance with the standard.

1.4 *This standard does not purport to address all of the safety concerns, if any, associated with its use. It is the responsibility of the user of this standard to establish appropriate safety and health practices and determine the applicability of regulatory limitations prior to use.*

### 2. Referenced Documents

2.1 *ASTM Standards:*<sup>2</sup>

D2013 Practice for Preparing Coal Samples for Analysis

D3174 Test Method for Ash in the Analysis Sample of Coal and Coke from Coal

### 3. Terminology

3.1 *Definitions of Terms Specific to This Standard:*

3.1.1 The critical temperature points to be observed are as follows, denoting the atmosphere used:

3.1.2 *fluid temperature, FT*—the temperature at which the fused mass has spread out in a nearly flat layer with a maximum height of 1.6 mm ( $\{1/16 \text{ in.}\}$ ) as shown by the fifth cone, FT, in Fig. 1.

3.1.3 *hemispherical temperature, HT*—the temperature at which the cone has fused down to a hemispherical lump at which point the height is one half the width of the base as shown by the fourth cone, HT, in Fig. 1.

3.1.4 *initial deformation temperature, IT*—the temperature at which the first rounding of the apex of the cone occurs. Shrinkage or warping of the cone ignored if the tip remains sharp. In Fig. 1, the first cone shown is an unheated one; the second cone IT is a typical cone at the initial deformation stage.

3.1.5 *softening temperature, ST*—the temperature at which the cone has fused down to a spherical lump in which the height is equal to the width at the base as shown by the third cone, ST, in Fig. 1.

### 4. Significance and Use

4.1 Design of most coal combustion and coal conversion equipment anticipates that the ash either remain solid or assume some degree of fluidity, depending on the particular design. Ash fusibility temperatures predict whether the ash will perform properly in the process for which the coal was chosen.

### 5. Apparatus and Materials

5.1 *Furnace*—Any gas-fired or electric furnace conforming to the following requirements may be used:

<sup>1</sup> This test method is under the jurisdiction of ASTM Committee D05 on Coal and Coke and is the direct responsibility of D05.21 on Methods of Analysis. Current edition approved July 1, 2004. Published July 2004. Originally approved 1961. Last previous edition approved 2003 as D1857-03. DOI: 10.1520/D1857-04. Current edition approved Sept. 1, 2010. Published November 2010. Originally approved 1961. Last previous edition approved 2004 as D1857-04. DOI: 10.1520/D1857-04R10.

<sup>2</sup> For referenced ASTM standards, visit the ASTM website, www.astm.org, or contact ASTM Customer Service at service@astm.org. For Annual Book of ASTM Standards volume information, refer to the standard's Document Summary page on the ASTM website.

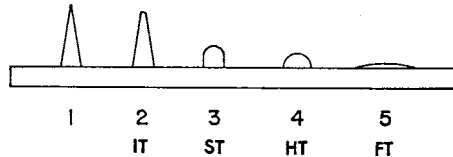

FIG. 1 Critical Temperature Points

5.1.1 Capable of maintaining a uniform temperature zone in which to heat the ash cones. This zone shall be such that the difference in the melting point of 12.7-mm ( $\frac{1}{2}$ -in.) pieces of pure gold wire when mounted in place of the ash cones on the cone support shall be not greater than 11°C (20°F) in a reducing atmosphere test run.

5.1.2 Capable of maintaining the desired atmosphere surrounding the cones during heating. The composition of the atmosphere, reducing or oxidizing, shall be maintained within the limits specified in Section 6. The desired atmosphere in the gas-fired furnace surrounding the cones shall be obtained by regulation of the ratio of gas to air in the combustion mixture. The desired atmosphere in the electric furnace shall be obtained by means of gases introduced into the heating chamber. The muffle shall be gas impervious, free from cracks, and the closure plug tight-fitting. The gas supply tube shall be sealed to the back wall of the preheating chamber and shall not extend to the front of the preheating chamber against the perforated baffle.

5.1.3 Capable of regulation so that the rate of temperature rise shall be  $8 \pm 3^\circ\text{C}$  ( $15 \pm 5^\circ\text{F}$ ) per minute.

5.1.4 Providing means of observing the ash cones during the heating. Observation on the same horizontal plane as the cone-support surface shall be possible.

5.2 *Cone Mold*—A commercially available cone mold as shown in Fig. 2. The cone shall be 19 mm ( $\frac{3}{4}$ -in.) in height and 6.4 mm ( $\frac{1}{4}$ -in.) in width at each side of the base which is an equilateral triangle. A steel spatula with a pointed tip, ground off to fit the cone depression in the mold, is suitable for removal of the ash cone.

5.3 *Optical Pyrometer or Thermocouple*, for temperature measurements, conforming to the following requirements:

5.3.1 *Optical Pyrometer*—An optical pyrometer of the disappearing filament type shall be used. The instrument shall have been calibrated to be accurate within 11°C (20°F) up to 1400°C (2550°F) and within 16°C (30°F) from 1400 to 1600°C (2550 to 2900°F) (Note 1). The pyrometer filament shall be sighted on the cones until the softening point temperature C (Fig. 1) has been passed, and then sighted on the cone support. The pyrometer shall have readable graduations not larger than 5.5°C (10°F).

NOTE 1—The pyrometer equipment shall be standardized periodically by a suitably equipped standardizing laboratory such as that of the National Bureau of Standards, or checked periodically against equipment certified by the Bureau of Standards.

5.3.2 *Thermocouple*—A thermocouple of platinum and platinum-rhodium, protected from the furnace gases by a glazed porcelain sheath, shall be used with a high-resistance millivoltmeter or potentiometer accurate and readable to within 5.5°C (10°F). The sheath shall be sealed to the furnace wall by alundum cement. The hot junction of the thermocouple shall touch

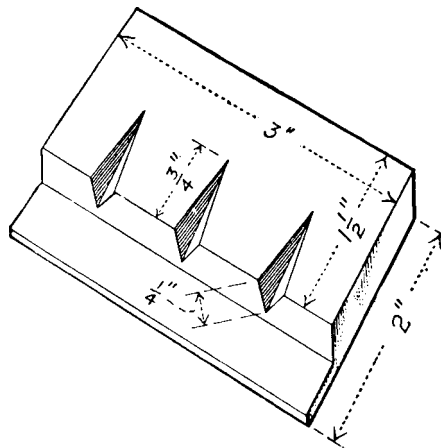

Inch-pound Units, in.	SI Units, mm
1/4	6.4
3/4	19.1
1 1/2	38.1
2	50.2
3	76.2

FIG. 2 Brass Cone Mold

the end of the sheath and shall be located in the center of the muffle and immediately to the rear of the cones. The thermocouple protective sheath shall be checked periodically for cracks. The thermocouple and its meter shall meet the requirements of Section 9. The potentiometer or millivoltmeter shall be so located or adequately shielded as to prevent radiant and convection heating of the cold junction. The room temperature compensator shall be adjusted to the existing temperature.

5.4 *Ash-Cone Refractory Support*—The ash cones shall be mounted on a refractory base composed of a mixture of equal parts by weight of kaolin and alumina conforming to the following requirements:

5.4.1 *Kaolin*—NF-grade powder passing a 75- $\mu\text{m}$  (No. 200) sieve.

5.4.2 *Aluminum Oxide*—Reagent grade ignited powder passing a 150- $\mu\text{m}$  (No. 100) sieve.

5.5 *Refractory Support Mold*—A mold with flat top and bottom surfaces to provide a refractory support of suitable thickness to minimize warping. A sidemold not over 6.4 mm (~~1/4 in.~~in.) high of any convenient shape, placed on an iron plate so that the top surface of the refractory mix can be struck off flat and parallel to the base by means of a straightedge, is satisfactory. For electric furnace use, legs not over 1/8 in. (~~3 mm~~)3 mm long may be provided on the corners of the cone support by suitable holes bored in the iron base plate of the mold.

5.6 *Gold Wire*<sup>3</sup>—0.51-mm diameter (twenty-four gage) or larger round wire of 99.98 % purity, but drawn from metal of 99.99 % purity, and having a melting point of 1063°C (~~1945°F~~)-1945°F.

5.7 *Nickel Wire*<sup>4</sup>—0.51-mm diameter (twenty-four gage) or larger round wire of CP nickel, 99.98 % pure, fully annealed, and having a melting point of 1452°C (~~2645°F~~)-2645°F.

## 6. Test Atmosphere

### 6.1 Gas-Fired Furnace:

6.1.1 *Reducing Atmosphere Test*—A mildly reducing atmosphere surrounding the cones shall be maintained during the test in the gas-fired furnace. Hydrogen, hydrocarbons, and carbon monoxide shall be considered as reducing gases; oxygen, carbon dioxide, and water vapor shall be considered as oxidizing gases. Nitrogen is inert. The ratio by volume of reducing gases to oxidizing gases in the atmosphere shall be between the limits of 20 to 80 and 80 to 20,<sup>5</sup> that is, on a nitrogen-free basis, the total amount of reducing gases present shall be between the limits of 20 and 80 volume %. A flame 152 to 203 mm (~~6 to 8 in.~~in.) in height and tinged with yellow above the furnace outlet has been found to provide an atmosphere within the specified limits.

6.1.2 *Oxidizing Atmosphere Test*—An atmosphere containing a minimum amount of reducing gases shall be maintained surrounding the cones during the test in the gas-fired furnace. On a nitrogen-free basis, the volume of reducing gases present in the atmosphere shall not exceed volume 10 %. Combustion with the maximum possible quantity of air with preservation of the specified rate of temperature increase has been found to provide an atmosphere within the specified limits. A completely blue flame, not over 50 mm (~~2 in.~~)2 in. in height above the outlet at the beginning of the test, provides the desired atmosphere; and, by regulation of the combustion gas-air ratio, the specified atmosphere and temperature rise can be maintained.

### 6.2 Electric Furnace:

6.2.1 *Reducing Atmosphere Test*—A regulated flow of gas of the nominal composition, 60 % carbon monoxide and 40  $\pm$  5 volume % carbon dioxide,<sup>6</sup> shall be maintained in the heating chamber throughout the test (Note 2) in the electric furnace. The gas stream shall be regulated by any convenient means to provide a measured flow of 1.3 to 1.5 furnace volumes per minute.

6.2.2 *Oxidizing Atmosphere Test*—A regulated stream of air shall be maintained throughout the test in the electric furnace. The gas stream shall be regulated by any convenient means to provide a measured flow of 1.3 to 1.5 furnace volumes per minute.

NOTE 2—Before using new cylinders of CO/CO<sub>2</sub> reducing gas, the contents should be mixed according to the gas manufacturer's recommendations. To assure that the gas remains mixed, the temperature of the cylinder contents should be maintained above the critical temperature at which CO<sub>2</sub> can liquify and separate.

## 7. Preparation of Ash

7.1 Use coal or coke passing a 250- $\mu\text{m}$  (No. 60) sieve prepared in accordance with Method D2013, to obtain the ash by incineration in a well-ventilated muffle furnace. The quantity of coal or coke required will vary with the ash content; usually 3 to 5 g of ash will be sufficient for cones for several check determinations, if necessary. Spread out the coal or coke in a layer not over 6.4 mm (~~1/4 in.~~in.) in depth in a fireclay or porcelain roasting dish. Place the dish in the cold muffle or on the hearth at a low temperature and gradually heat to redness at such a rate as to avoid mechanical loss from too rapid expulsion of volatile matter (Note 3). Complete the conversion to ash at a temperature of 800 to 900°C (~~1470~~1470 to ~~1650°F~~)-1650°F. Transfer the ash to an agate mortar (Note 4) and grind it so that it will pass a 75- $\mu\text{m}$  (No. 200) sieve. Then spread the ash in a thin layer in a fireclay, silica, or porcelain dish and ignite it in a stream of oxygen for 1 1/2 h at 800 to 850°C (~~1470~~1470 to ~~1560°F~~)-1560°F to ensure complete and uniform oxidation of the ash. Any tube or muffle-type furnace which, when supplied with an oxygen flow of not less than one furnace volume in 5 min, will maintain a highly oxidizing atmosphere and will be suitable.

<sup>3</sup> Gold wire of this purity can be purchased from the Baker Dental Division of Engelhard Industries, Inc., 850 Passaic Ave., East Newark, NJ 07029 or from Leico Industries, Inc., 250 W. 57th St., New York, NY 10019.

<sup>4</sup> Nickel wire of this purity can be purchased with the additional specification of having a minimum coefficient of resistance for 0 to 100°C of 0.006 73  $\Omega/\Omega\cdot^\circ\text{C}$ , from Leico Industries, Inc., 250 W. 57th St., New York, NY 10019.

<sup>5</sup> For information concerning the effect of various atmospheres, see U.S. Bureau of Mines *Bulletin 129*, 1918.

<sup>6</sup> This gas is available from the Matheson Gas Co., Inc.