



Designation: E1922 – 04(Reapproved 2010)^{ε1}

Standard Test Method for Translaminar Fracture Toughness of Laminated and Pultruded Polymer Matrix Composite Materials¹

This standard is issued under the fixed designation E1922; the number immediately following the designation indicates the year of original adoption or, in the case of revision, the year of last revision. A number in parentheses indicates the year of last reapproval. A superscript epsilon (ϵ) indicates an editorial change since the last revision or reapproval.

^{ε1} NOTE—1.6 and 3.2.1 were editorially updated in January 2011.

1. Scope

1.1 This test method covers the determination of translaminar fracture toughness, K_{TL} , for laminated and pultruded polymer matrix composite materials of various ply orientations using test results from monotonically loaded notched specimens.

1.2 This test method is applicable to room temperature laboratory air environments.

1.3 Composite materials that can be tested by this test method are not limited by thickness or by type of polymer matrix or fiber, provided that the specimen sizes and the test results meet the requirements of this test method. This test method was developed primarily from test results of various carbon fiber – epoxy matrix laminates and from additional results of glass fiber – epoxy matrix, glass fiber-polyester matrix pultrusions and carbon fiber – bismaleimide matrix laminates (1-4, 5, 6).²

1.4 A range of eccentrically loaded, single-edge-notch tension, ESE(T), specimen sizes with proportional planar dimensions is provided, but planar size may be variable and adjusted, with associated changes in the applied test load. Specimen thickness is a variable, independent of planar size.

1.5 Specimen configurations other than those contained in this test method may be used, provided that stress intensity calibrations are available and that the test results meet the requirements of this test method. It is particularly important that the requirements discussed in 5.1 and 5.4 regarding contained notch-tip damage be met when using alternative specimen configurations.

1.6 The values stated in SI units are to be regarded as standard. No other units of measurement are included in this standard.

¹ This test method is under the jurisdiction of ASTM Committee E08 on Fatigue and Fracture and is the direct responsibility of Subcommittee E08.05 on Cyclic Deformation and Fatigue Crack Formation.

Current edition approved Oct. 1, 2010. Published January 2011. Originally approved in 1997. Last previous edition approved in 2004 as E1922-04. DOI: 10.1520/E1922-04R10E01.

² The boldface numbers in parentheses refer to the list of references at the end of this standard.

1.7 This standard does not purport to address all of the safety concerns, if any, associated with its use. It is the responsibility of the user of this standard to establish appropriate safety and health practices and to determine the applicability of regulatory limitations prior to use.

2. Referenced Documents

2.1 ASTM Standards:³

D883 Terminology Relating to Plastics

D3039/D3039M Test Method for Tensile Properties of Polymer Matrix Composite Materials

D3878 Terminology for Composite Materials

D5229/D5229M Test Method for Moisture Absorption Properties and Equilibrium Conditioning of Polymer Matrix Composite Materials

D5528 Test Method for Mode I Interlaminar Fracture Toughness of Unidirectional Fiber-Reinforced Polymer Matrix Composites

E4 Practices for Force Verification of Testing Machines

E6 Terminology Relating to Methods of Mechanical Testing

E83 Practice for Verification and Classification of Extensometer Systems

E399 Test Method for Linear-Elastic Plane-Strain Fracture Toughness K_{Ic} of Metallic Materials

E1823 Terminology Relating to Fatigue and Fracture Testing

3. Terminology

3.1 Definitions:

3.1.1 Terminology E6, E1823, and D3878 are applicable to this test method.

3.2 Definitions of Terms Specific to This Standard:

3.2.1 notch-mouth displacement, V_n [L]—the Mode I (also called opening mode) component of crack or notch displacement due to elastic and permanent deformation. The displacement is measured across the mouth of the notch on the specimen edge (see Fig. 1).

³ For referenced ASTM standards, visit the ASTM website, www.astm.org, or contact ASTM Customer Service at service@astm.org. For Annual Book of ASTM Standards volume information, refer to the standard's Document Summary page on the ASTM website.

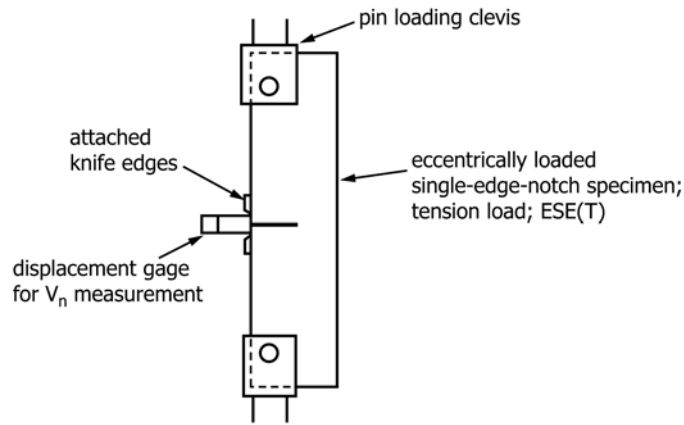

FIG. 1 Test Arrangement for Translaminar Fracture Toughness Tests

3.2.2 notch length, a_n [L]—the distance from a reference plane to the front of the machined notch. The reference plane depends on the specimen form, and normally is taken to be either the boundary, or a plane containing either the load line or the centerline of a specimen or plate. The reference plane is defined prior to specimen deformation (see Fig. 2).

3.2.3 normalized notch size, a_n/W [nd]—the ratio of notch length, a_n , to specimen width, W .

3.2.4 For additional information, see Terminology D883 and Test Methods D3039/D3039M, D5229/D5229M, and D5528.

4. Summary of Test Method

4.1 This test method involves tension testing of eccentrically loaded, single-edge-notch, ESE(T), specimens in opening mode loading. Load versus displacement across the notch at the specimen edge, V_n , is recorded. The load corresponding to a prescribed increase in normalized notch length is determined, using the load-displacement record. The translaminar fracture toughness, K_{TL} , is calculated from this load using equations that have been established on the basis of elastic stress analysis of the modified single-edge notched specimen.

4.2 The validity of translaminar fracture toughness, K_{TL} , determined by this test method depends on maintaining a relatively contained area of damage at the notch tip. To maintain this suitable notch-tip condition, the allowed increase in notch-mouth displacement near the maximum load point of the tests is limited to a small value. Small increases in notch-mouth displacement are more likely for relatively thick

samples and for samples with a significant proportion of the near surface reinforcing fibers aligned parallel to the direction of the notch.

5. Significance and Use

5.1 The parameter K_{TL} determined by this test method is a measure of the resistance of a polymer matrix composite laminate to notch-tip damage and effective translaminar crack growth under opening mode loading. The result is valid only for conditions in which the damage zone at the notch tip is small compared with the notch length and the in-plane specimen dimensions.

5.2 This test method can serve the following purposes. In research and development, K_{TL} data can quantitatively establish the effects of fiber and matrix variables and stacking sequence of the laminate on the translaminar fracture resistance of composite laminates. In acceptance and quality control specifications, K_{TL} data can be used to establish criteria for material processing and component inspection.

5.3 The translaminar fracture toughness, K_{TL} , determined by this test method may be a function of the testing speed and temperature. This test method is intended for room temperature and quasi-static conditions, but it can apply to other test conditions provided that the requirements of 9.2 and 9.3 are met. Application of K_{TL} in the design of service components should be made with awareness that the test parameters specified by this test may differ from service conditions, possibly resulting in a different material response than that seen in service.

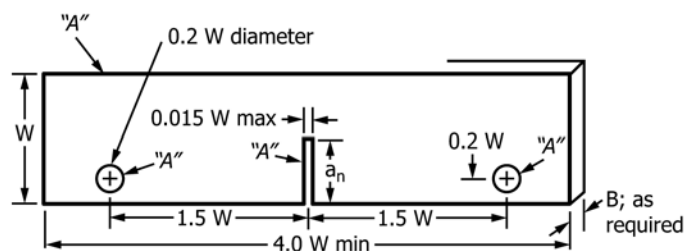

NOTE 1—All dimensions +/- 0.01 W, except as noted.

NOTE 2—A surfaces perpendicular and parallel as applicable within 0.01 W.

FIG. 2 Translaminar Fracture Toughness Test Specimen