

---

---

## Paints and varnishes — Cross-cut test

*Peintures et vernis — Essai de quadrillage*

iTeh Standards  
(<https://standards.iteh.ai>)  
Document Preview

[ISO 2409:2020](https://standards.iteh.ai/catalog/standards/iso/15febbbba-0f40-423f-a45e-a3e170615e6e/iso-2409-2020)

<https://standards.iteh.ai/catalog/standards/iso/15febbbba-0f40-423f-a45e-a3e170615e6e/iso-2409-2020>



iTeh Standards  
(<https://standards.iteh.ai>)  
Document Preview

[ISO 2409:2020](https://standards.iteh.ai/catalog/standards/iso/15febbbba-0f40-423f-a45e-a3e170615e6e/iso-2409-2020)

<https://standards.iteh.ai/catalog/standards/iso/15febbbba-0f40-423f-a45e-a3e170615e6e/iso-2409-2020>



**COPYRIGHT PROTECTED DOCUMENT**

© ISO 2020

All rights reserved. Unless otherwise specified, or required in the context of its implementation, no part of this publication may be reproduced or utilized otherwise in any form or by any means, electronic or mechanical, including photocopying, or posting on the internet or an intranet, without prior written permission. Permission can be requested from either ISO at the address below or ISO's member body in the country of the requester.

ISO copyright office  
CP 401 • Ch. de Blandonnet 8  
CH-1214 Vernier, Geneva  
Phone: +41 22 749 01 11  
Email: [copyright@iso.org](mailto:copyright@iso.org)  
Website: [www.iso.org](http://www.iso.org)

Published in Switzerland

# Contents

Page

<b>Foreword</b> .....	<b>iv</b>
<b>1 Scope</b> .....	<b>1</b>
<b>2 Normative references</b> .....	<b>1</b>
<b>3 Terms and definitions</b> .....	<b>1</b>
<b>4 Principle</b> .....	<b>2</b>
<b>5 Apparatus</b> .....	<b>2</b>
5.1 General.....	2
5.2 Cutting tool.....	2
5.2.1 General requirements.....	2
5.2.2 Single-blade cutting tools.....	2
5.2.3 Multi-blade cutting tools.....	2
5.3 Guiding and spacing edges.....	5
5.4 Viewing lens.....	5
<b>6 Sampling</b> .....	<b>6</b>
<b>7 Test specimen</b> .....	<b>7</b>
7.1 Substrate.....	7
7.2 Thickness of coating.....	7
<b>8 Procedure</b> .....	<b>7</b>
8.1 General.....	7
8.1.1 Test conditions.....	7
8.1.2 Conditioning of the test panels.....	7
8.1.3 Number of cuts.....	7
8.1.4 Spacing of cuts.....	7
8.1.5 Number of determinations.....	8
8.2 Cutting the coating using the manual procedure.....	8
8.3 Cutting the coating using a motor-driven tool.....	8
<b>9 Evaluation and expression of results</b> .....	<b>8</b>
<b>10 Designation of the test result</b> .....	<b>9</b>
<b>11 Precision</b> .....	<b>10</b>
11.1 Repeatability limit, <i>r</i> .....	10
11.2 Reproducibility limit, <i>R</i> .....	10
<b>12 Test report</b> .....	<b>10</b>
<b>Annex A (informative) Examples of suitable procedures for removing loose paint</b> .....	<b>12</b>
<b>Bibliography</b> .....	<b>14</b>

## Foreword

ISO (the International Organization for Standardization) is a worldwide federation of national standards bodies (ISO member bodies). The work of preparing International Standards is normally carried out through ISO technical committees. Each member body interested in a subject for which a technical committee has been established has the right to be represented on that committee. International organizations, governmental and non-governmental, in liaison with ISO, also take part in the work. ISO collaborates closely with the International Electrotechnical Commission (IEC) on all matters of electrotechnical standardization.

The procedures used to develop this document and those intended for its further maintenance are described in the ISO/IEC Directives, Part 1. In particular, the different approval criteria needed for the different types of ISO documents should be noted. This document was drafted in accordance with the editorial rules of the ISO/IEC Directives, Part 2 (see [www.iso.org/directives](http://www.iso.org/directives)).

Attention is drawn to the possibility that some of the elements of this document may be the subject of patent rights. ISO shall not be held responsible for identifying any or all such patent rights. Details of any patent rights identified during the development of the document will be in the Introduction and/or on the ISO list of patent declarations received (see [www.iso.org/patents](http://www.iso.org/patents)).

Any trade name used in this document is information given for the convenience of users and does not constitute an endorsement.

For an explanation of the voluntary nature of standards, the meaning of ISO specific terms and expressions related to conformity assessment, as well as information about ISO's adherence to the World Trade Organization (WTO) principles in the Technical Barriers to Trade (TBT), see [www.iso.org/iso/foreword.html](http://www.iso.org/iso/foreword.html).

This document was prepared by Technical Committee ISO/TC 35, *Paints and varnishes*, Subcommittee SC 9, *General test methods for paints and varnishes*, in collaboration with the European Committee for Standardization (CEN) Technical Committee CEN/TC 139, *Paints and varnishes*, in accordance with the Agreement on technical cooperation between ISO and CEN (Vienna Agreement).

This fifth edition cancels and replaces the fourth edition (ISO 2409:2013), which has been technically revised. The main changes compared to the previous edition are as follows:

- [Clause 3](#) has been added;
- [Clause 4](#) has been added;
- the general requirements for the use of single-cutting tools and multi-cutting tools in [5.2.1](#) have been updated;
- references to commercially available cutters have been deleted from [5.2.2.3](#);
- coating of the test panels has been deleted from [Clause 7](#), because final test specimen are assumed;
- the text has been editorially revised and the normative references have been updated.

Any feedback or questions on this document should be directed to the user's national standards body. A complete listing of these bodies can be found at [www.iso.org/members.html](http://www.iso.org/members.html).

# Paints and varnishes — Cross-cut test

## 1 Scope

This document specifies a test method for assessing the resistance of paint coatings and varnishes (including wood stains) to separation from substrates when a right-angle lattice pattern is cut into the coating, penetrating through to the substrate. The property determined by this empirical test procedure depends, among other factors, on the adhesion of the coating to either the preceding coat or the substrate. This procedure is not, however, a means of measuring adhesion.

NOTE 1 Where a measurement of adhesion is required, see the method described in ISO 4624.

NOTE 2 Although the test is primarily intended for use in the laboratory, the test is also suitable for field testing.

The method described can be used either as a pass/fail test or, where circumstances are appropriate, as a six-step classification test. When applied to a multi-coat system, assessment of the resistance to separation of individual layers of the coating from each other can be made.

The test can be carried out on finished objects and/or on specially prepared test specimens.

Although the method is applicable to paint on hard (e.g. metal) and soft (e.g. wood and plaster) substrates, these different substrates need a different test procedure (see [Clause 8](#)).

The method is not suitable for coatings of total thickness greater than 250 µm or for textured coatings.

NOTE 3 The method, when applied to coatings designed to give a rough patterned surface, will give results which will show too much variation (see also ISO 16276-2).

## 2 Normative references

[ISO 2409:2020](#)

<https://standards.iteh.ai/catalog/standards/iso/15febbbba-0f40-423f-a45e-a3e170615e6e/iso-2409-2020>

The following documents are referred to in the text in such a way that some or all of their content constitutes requirements of this document. For dated references, only the edition cited applies. For undated references, the latest edition of the referenced document (including any amendments) applies.

ISO 1513, *Paints and varnishes — Examination and preparation of test samples*

ISO 2808, *Paints and varnishes — Determination of film thickness*

ISO 4618, *Paints and varnishes — Terms and definitions*

ISO 13076, *Paints and varnishes — Lighting and procedure for visual assessments of coatings*

ISO 15528, *Paints, varnishes and raw materials for paints and varnishes — Sampling*

## 3 Terms and definitions

For the purposes of this document, the terms and definitions given in ISO 4618 apply.

ISO and IEC maintain terminological databases for use in standardization at the following addresses:

- ISO Online browsing platform: available at <https://www.iso.org/obp>
- IEC Electropedia: available at <http://www.electropedia.org/>

## 4 Principle

Six parallel cuts are introduced in the coating and another six cuts are introduced perpendicular to the first cuts. Any loose paint particles are removed. The cut area is examined visually and compared to a six-step classification.

## 5 Apparatus

### 5.1 General

Use ordinary laboratory apparatus, together with the apparatus specified in [5.2](#) to [5.4](#).

### 5.2 Cutting tool

#### 5.2.1 General requirements

It is particularly important to ensure that the cutting tool is capable of creating the specified V-shape throughout the total coating thickness, and that the cutting edges are in good condition. Suitable tools are described in [5.2.2](#) and [5.2.3](#) and shown in [Figures 1](#) and [2](#).

A single-blade cutting tool ([5.2.2](#)) as well as the multi-blade cutting tool ([5.2.3](#)) are suitable for all coatings and substrates; it shall be ensured that all cuts mark or scratch the substrate. The depth of indentation into the substrate shall be as low as possible, however.

The tools described in [5.2.2](#) and [5.2.3](#) are suitable for manual use, which is the more usual method of use, but the tools may also be mounted on a motor-driven apparatus, which gives more uniform cutting. The application of the latter procedure shall be subject to agreement between the interested parties.

The apparatus (manual or motor-driven) and the type of cutting tool used have an influence on the test result. Results obtained with different types of cutting tool cannot be directly compared. For each test series, the same cutting tool shall be used.

#### 5.2.2 Single-blade cutting tools

**5.2.2.1 Hand-held single-blade cutting tool** with a cutting edge as shown in [Figure 1 a](#)).

**5.2.2.2 Single-blade cutting tool** used in motor-driven apparatus as shown in [Figure 3](#).

**5.2.2.3 Cutter with a rigid blade** with a V-shaped cutting edge as shown in [Figure 1 b](#)).

The specific thickness of the blade is not specified, as long as the blade is rigid and the cut produced is V-shaped through the whole thickness of the coating.

NOTE The cutter blade is designed to be broken in a defined manner so that a sharp blade is available at any time.

#### 5.2.3 Multi-blade cutting tools

**5.2.3.1 Hand-held multi-blade cutting tool** with cutting edges as shown in [Figure 2](#).

**5.2.3.2 Multi-blade cutting tool** used in motor-driven apparatus as shown in [Figure 3](#).

The multi-blade cutting tool shall have six cutting edges spaced 1 mm, 2 mm or 3 mm apart. In addition, two guide edges (see [Figure 2](#)) are necessary to make handling easier. The guide edges and the cutting edges shall lie in one plane (see [Figure 2](#)).

Dimensions in millimetres

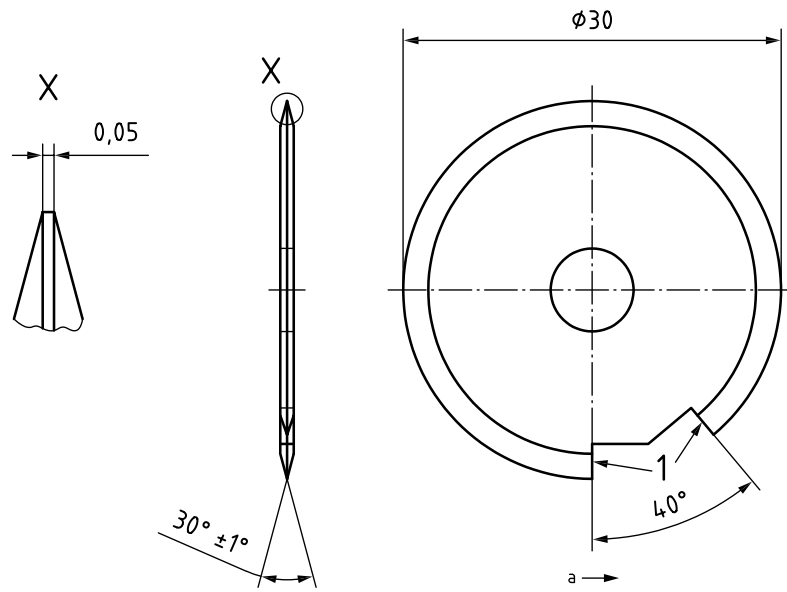

a) Hand-held single-blade cutting tool

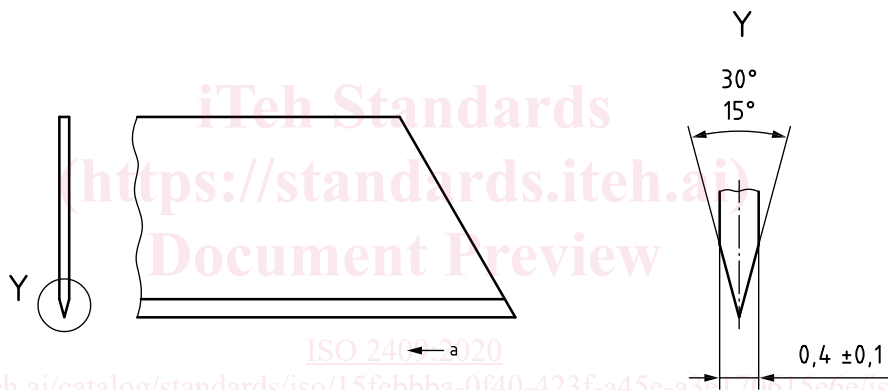

b) Cutter with rigid blade with V-shaped cutting edge (see 5.2.2.3)

**Key**

- 1 cutting edges
- a Direction of cut.

NOTE All dimensions approximate except where tolerances are specifically indicated.

**Figure 1 — Examples of single-blade cutting tools**

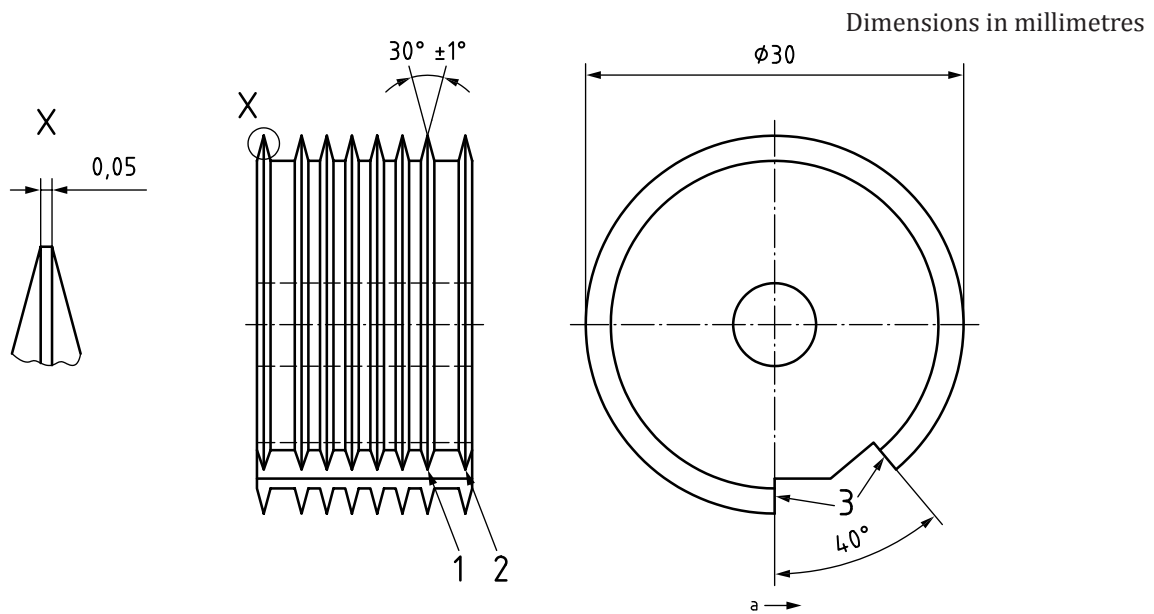

a) Hand-held multi-blade cutting tool

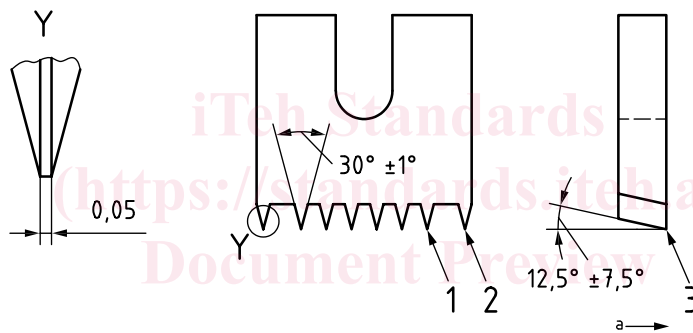

b) Multi-blade cutting tool used in motor-driven apparatus

**Key**

- 1 cutting blade
- 2 guide edge
- 3 cutting edges
- a Direction of cut.

NOTE All dimensions are approximate.

**Figure 2 — Examples of multi-blade cutting tools**

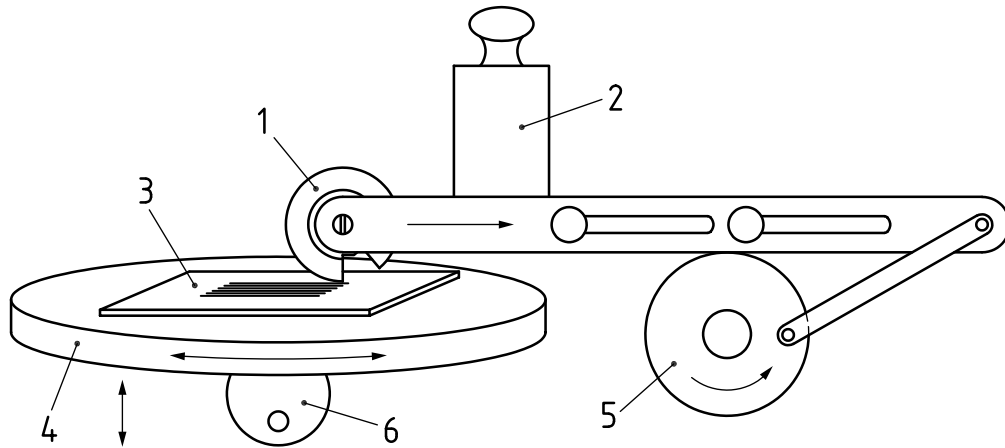

**Key**

- 1 cutting tool
- 2 weight
- 3 test panel
- 4 rotating test panel holder
- 5 motor
- 6 handle for rotating the test panel holder

**Figure 3 — Motor-driven apparatus**

### 5.3 Guiding and spacing edges

In order to space the cuts correctly, a series of guiding and spacing edges is necessary when using a single-blade cutting tool.

A folding ruler suitable for use with hand-held single-blade cutting tools (5.2.2.1) is shown in Figure 4 a).

A series of guiding edges suitable for use with cutters with a rigid blade with a V-shaped cutting edge (see 5.2.2.3) is shown in Figure 4 b).

### 5.4 Viewing lens

Use a hand-held lens with a magnification of  $\times 2$  or  $\times 3$ .

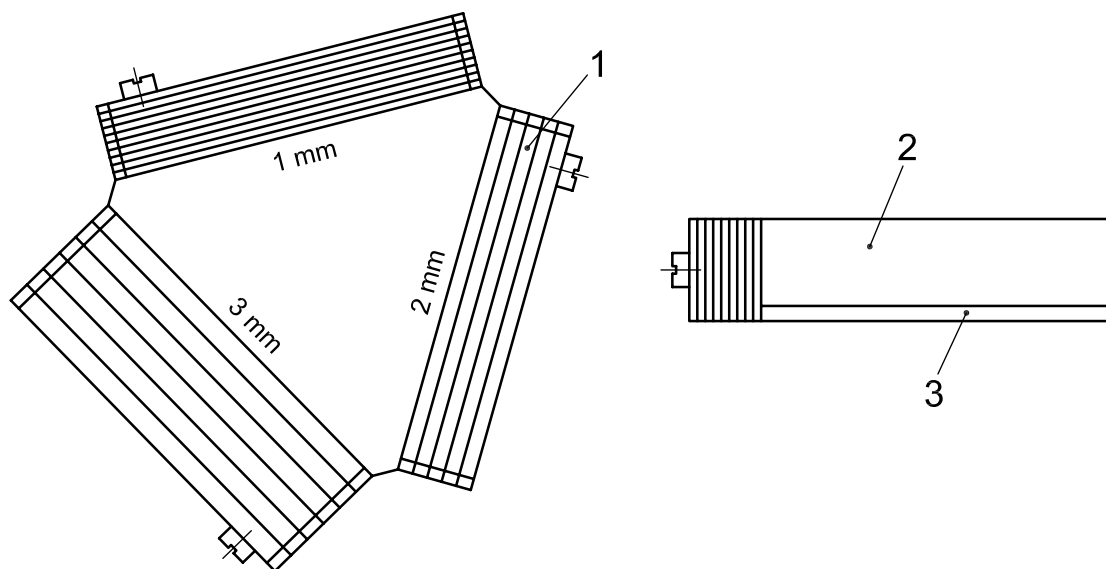

a) Series of spacing edges of the folding ruler

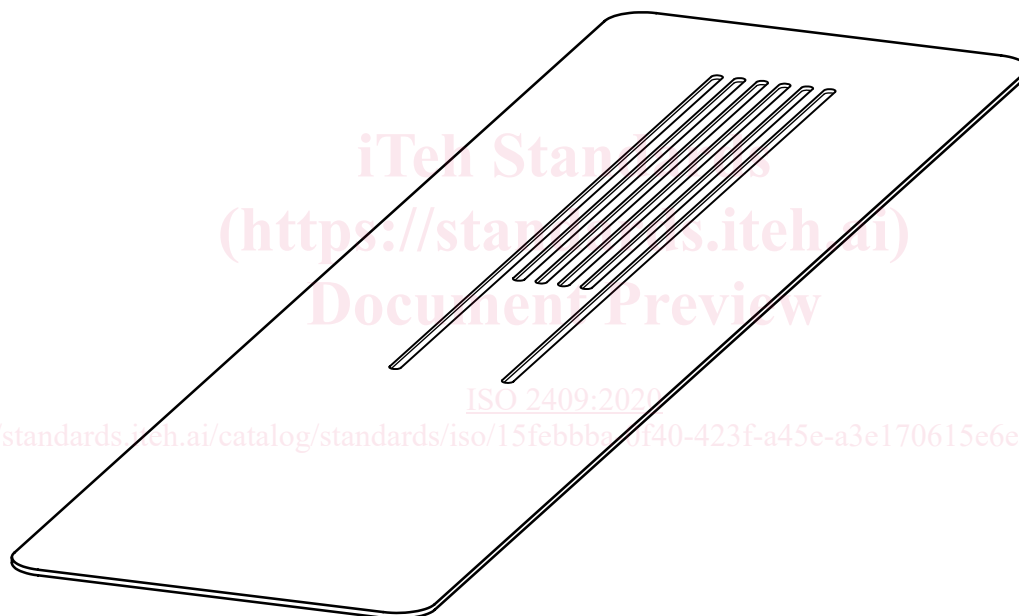

b) Series of guiding edges

**Key**

- 1 spacing edges for 1 mm, 2 mm and 3 mm cuts
- 2 laminated plastic or steel
- 3 rubber

**Figure 4 — Examples of guiding and spacing edges**

## 6 Sampling

Take a representative sample of the product to be tested, as described in ISO 15528.

Examine and prepare each sample for testing, as described in ISO 1513.