



Designation: ~~D4724-10~~ Designation: D4724 – 11

# Standard Test Method for Entanglements in Untwisted Filament Yarns by Needle Insertion<sup>1</sup>

This standard is issued under the fixed designation D4724; the number immediately following the designation indicates the year of original adoption or, in the case of revision, the year of last revision. A number in parentheses indicates the year of last reapproval. A superscript epsilon ( $\epsilon$ ) indicates an editorial change since the last revision or reapproval.

## 1. Scope

1.1 This test method covers two options for the measurement of entanglements in untwisted filament yarns using needle insertion options for instrument (A) and manual (B) techniques.

1.2 The values stated in either SI or inch-pound units (in parentheses) are to be regarded separately as standard. The values stated in each system may not be exact equivalents; therefore, each system must be used independently of the other without combining values in any way.

1.3 *This standard does not purport to address all of the safety concerns, if any, associated with its use. It is the responsibility of the user of this standard to establish appropriate safety and health practices and determine the applicability of regulatory limitations prior to use.*

## 2. Referenced Documents

2.1 *ASTM Standards:*<sup>2</sup>

D123 [Terminology Relating to Textiles](#)

D1776 [Practice for Conditioning and Testing Textiles](#)

D2258 ~~[Practice for Sampling Yarn for Testing](#)~~ [Practice for Sampling Yarn for Testing](#)

D4849 [Terminology Related to Yarns and Fibers](#)

## 3. Terminology

3.1 *Definitions:*

3.1.1 *entanglement, n*—the extent or degree to which the filaments in a yarn are interlocked and cannot be readily separated.

3.1.1.1 *Discussion*—There are two kinds of entanglements, intermediary (loose) node and hard (tight) node. Intermediary nodes are pulled out easily under tension or separated by a needle. This test method is a measure of the presence of hard nodes in which the interlocking or interlacing is compact pulling the yarn bundle together.

3.1.2 *filament yarn, n*—a yarn composed of (continuous) filaments assembled with or without twist.

3.1.1 For definitions of terms relating to yarns and fibers, refer to Terminology D4849.

3.1.1.1 The following terms are relevant to this standard: [entanglement](#), [filament yarn](#).

3.2 For definitions of other textile terms used in this test method, refer to Terminology D123.

## 4. Summary of Test Method

4.1 A summary of each option is in the section for that option.

## 5. Significance and Use

5.1 Option 1 of this test method for the determination of the degree of untwisted filament yarn entanglement, as measured instrumentally, is used for acceptance testing of commercial shipments; however, caution is advised because information on between-laboratory precision is lacking. Comparative tests, as directed in 5.1.1, may be advisable.

5.1.1 If there are differences of practical significance between the reported test results for two or more laboratories, comparative tests should be performed by those laboratories to determine if there is a statistical bias between them, using competent statistical assistance. As a minimum, samples used for each comparative test should be as homogeneous as possible, drawn from the same lot of material as the samples that results in disparate results during initial testing, and randomly assigned in equal numbers to each

<sup>1</sup> This test method is under the jurisdiction of ASTM Committee D13 on Textiles and is the direct responsibility of Subcommittee D13.58 on Yarns and Fibers.

Current edition approved Aug. 1, 2010. Published September 2010. Originally approved in 1999. Last previous edition approved in 2009 as D4724-09: D4724-10. DOI: 10.1520/D4724-10.1.

<sup>2</sup> For referenced ASTM standards, visit the ASTM website, [www.astm.org](http://www.astm.org), or contact ASTM Customer Service at [service@astm.org](mailto:service@astm.org). For *Annual Book of ASTM Standards* volume information, refer to the standard's Document Summary page on the ASTM website.

laboratory. Other fabrics with established test values may be used for this purpose. The test results from the laboratories involved should be compared appropriate statistical analysis and a probability level chosen by the two parties before testing begins, at a probability level chosen prior to the testing series. If a bias is found, either its cause must be found and corrected or future test results must be adjusted in consideration of the known bias.

5.2 Option 2 for this test method is intended for use when the supply of yarn is limited.

5.3 The instrumental option of this test method is based on the total randomization of the entanglements in the yarn; therefore, the distance measured between the point of insertion of a pin in the middle of the yarn and the point at which an entanglement is encountered, by movement of the yarn or the pin until it is stopped at a preset level of force, is representative of the distance between two entanglements at some location in the yarn.

5.4 Entanglements are used frequently instead of twist to ensure the integrity of filament yarns. Such entanglements generally give somewhat less protection during weaving or knitting than twist, but with proper care, will perform quite satisfactorily.

## 6. Sampling and Test Specimens

6.1 *Primary Sampling Unit*—Consider shipping containers of yarn to be the primary sampling unit.

NOTE 1—A realistic specification or other agreement between the purchaser and the supplier requires taking into account the variability between shipping containers, packages within a shipping container, and successive lengths from a package to provide a plan that, at the specified level for the property of interest, has a meaningful producer's risk, consumer's risk, acceptable quality level, and limiting quality level.

6.2 *Laboratory Sample Unit*—For each primary sampling unit, take laboratory sampling units as directed in Practice D2258. Do not rewind or transfer material from packages taken from shipping containers to another packages.

6.3 *Test Specimen*—For acceptance testing, use laboratory units as a source of specimens. Make 20 observations on each laboratory sampling unit.

## 7. Conditioning

7.1 *Preparation of Test Package*—Before preconditioning or conditioning the test package, remove at least 100 m or 110 yds of yarn from the test package to avoid testing nonrepresentative yarn.

7.2 *Preconditioning*—Normally, preconditioning is not necessary unless the test packages are received with higher than the normal moisture level. If preconditioning is necessary, treat the packages as directed in Practice D1776.

7.3 *Conditioning*—Condition the test packages as directed in Practice D1776.

## OPTION 1—INSTRUMENTAL MEASUREMENT OF THE DEGREE OF ENTANGLEMENT OF UNTWISTED FILAMENT YARN

## 8. Summary of Option

8.1 A yarn is passed at constant speed and constant pretension through the thread path of the instrument. After a required yarn length has run through, the yarn is pierced by a needle, and advanced automatically until a preset needle tension is attained. Then, the needle is withdrawn, and the yarn length from insertion to this critical point is measured automatically. This cycle of yarn advance, piercing by the needle, and length measurement is repeated for a predetermined number of times. The individual measured pulled yarn lengths and the total of these yarn lengths are automatically recorded.

## 9. Apparatus

9.1 *Automatic Needle Pull Entanglement Testers*, rapid automatic pin insertion detector (RAPID)<sup>3</sup> and Rothschild automatic yarn entanglement testers NPT.<sup>3</sup>

9.2 *Standard Laboratory Weights*, ranging from 1 to 100 g.

9.3 *Stopwatch*, with 1/5-s divisions.

9.4 *Speed Indicator*, tachometer, 0 to 1000 rpm range.

9.5 *Magnetic Whorl Tensioning Device*, optional.

## 10. Procedure

10.1 Test the yarn in the standard atmosphere for testing textiles, as directed in Practice D1776.

10.2 Calibrate the entanglement tester and tensiometer as prescribed by the instrument manufacturer.

10.3 Mount the test package on a suitable holder.

10.4 *Yarn Pretension*—Calculate the pretension by using one of the equations below:

$$YP (g) = (D \wedge 0.5) 0.75 \quad (1)$$

$$YP (cN) = (T \wedge 0.5) * 0.70 \quad (2)$$

10.5 *Trip Level Tension*—Calculate the trip level by using one of the equations below:

<sup>3</sup> Apparatus is commercially available.

$$TLT(g) = (D \wedge 0.35) * 3.5 \tag{3}$$

$$TLT(cN) = (T \wedge 0.35) * 3.31 \tag{4}$$

where:

- YP = Yarn pretension,
- TLT = trip level tension, c/tex (gf/d),
- T = linear density, tex,
- D = linear density, denier, and
- F = filament count.

10.6 Set the RAPID instrument as follows:

10.6.1 *Measuring Speed*—10–20 m/min.

10.6.2 *Observations/Package*—20.

10.6.3 *No-Show Length*—Refer to the manufacturer’s manual.

10.6.4 Present the loose end of the yarn to the inlet gun (see Fig. 1). The instrument will string up, automatically strip some yarn, start the measurement cycle, and discard the tested yarn to waste.

10.6.4.1 If there is no entanglement in the “No-Show” length, the instrument will do the following:

(1) If the “Pin Miss Ignored Limit” has not been exceeded, rotate the pinwheel, reinsert the needle in the yarn, and continue testing. The test is aborted and a “No-Show” recorded.

(2) If the “Pin Miss Ignored Limit” has been exceeded, enter a “Freeze” state and request confirmation of pin insertion. The operator will restart the test if the pin did not pierce the yarn (increasing the “Pin Miss Count” by 1, or the operator will acknowledge pin piercing by pressing the “Confirm” button designating this a true no entanglement section, which adds the length to the results.

10.7 Set the Rothschild instrument as follows:

10.7.1 *Measuring Speed*—10–20 m/min.

10.7.2 *Forwarding Time*—5 s.

10.7.3 *Observations/Package (decade counter)*—20.

10.7.4 *No-Show Length*—500 mm or as specified by user. This is an optional setting and the length should be established based on the product or end-use of the product.

10.7.5 Feed the yarn from the package through the pretension device. The yarn then is threaded across the needle piercing section and through the measuring head. Then, yarn goes to a yarn speed roll and is taken up to the “Take-up” wheel (see Fig. 2) or can bypass the “Take-up” wheel and go into the aspirator after the yarn speed roll, to prevent buildup on the take-up wheel. The software initializes a specified length for stripping and starts the test.

10.7.5.1 If there is no entanglement in the “No-Show” length, the instrument will do the following:

- (1) Stop the yarn and withdraw the needle.
- (2) Record a “No-Show” in the software (and on the printout).
- (3) Reinsert the needle into the yarn and wind until a node (entanglement) is detected.
- (4) The first entanglement after a “No-Show” is ignored.
- (5) The needle is withdrawn, and the yarn is advanced the specified length of the entanglement and is reinserted into the yarn and the test continues. This is to ensure that an accurate reference between entanglement is established.

10.7.6 Remove the yarn from the take-up wheel frequently to avoid excessive waste build-up. Use care if a sharp blade is used. To avoid any build-up, the yarn may be placed in the aspirator after the last wrap on the “Yarn speed roll.”

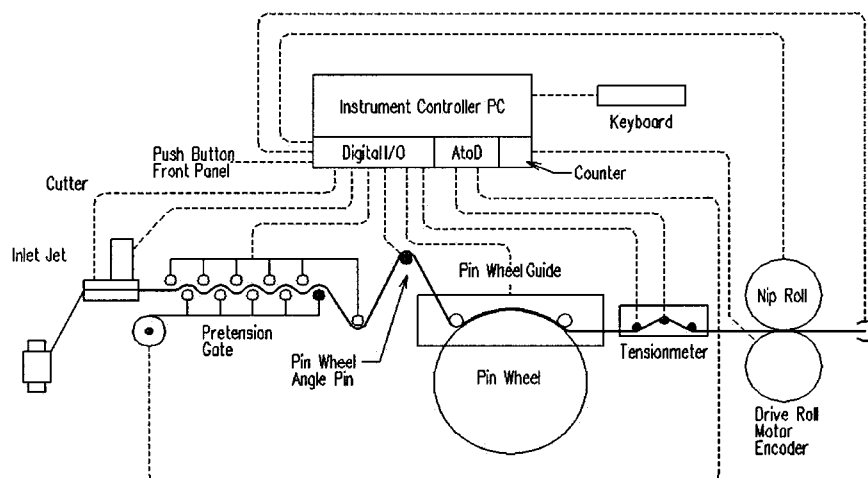

FIG. 1 Yarn String-Up Diagram for Rapid Automatic Pin Insertion Detector (RAPID)