

---

---

**Paints and varnishes —  
Determination of the scratch  
resistance of a coating system using a  
laboratory-scale car-wash**

*Peintures et vernis — Détermination de la résistance à la rayure d'un  
système de peinture sur un poste de lavage automobile de laboratoire*

**iTeh STANDARD PREVIEW**  
**(standards.iteh.ai)**

[ISO 20566:2020](https://standards.iteh.ai/catalog/standards/sist/fc1489ed-6805-46c5-8633-e8c61dc478d7/iso-20566-2020)

[https://standards.iteh.ai/catalog/standards/sist/fc1489ed-6805-46c5-8633-  
e8c61dc478d7/iso-20566-2020](https://standards.iteh.ai/catalog/standards/sist/fc1489ed-6805-46c5-8633-e8c61dc478d7/iso-20566-2020)



**iTeh STANDARD PREVIEW**  
**(standards.iteh.ai)**

ISO 20566:2020

<https://standards.iteh.ai/catalog/standards/sist/fc1489ed-6805-46c5-8633-e8c61dc478d7/iso-20566-2020>



**COPYRIGHT PROTECTED DOCUMENT**

© ISO 2020

All rights reserved. Unless otherwise specified, or required in the context of its implementation, no part of this publication may be reproduced or utilized otherwise in any form or by any means, electronic or mechanical, including photocopying, or posting on the internet or an intranet, without prior written permission. Permission can be requested from either ISO at the address below or ISO's member body in the country of the requester.

ISO copyright office  
CP 401 • Ch. de Blandonnet 8  
CH-1214 Vernier, Geneva  
Phone: +41 22 749 01 11  
Fax: +41 22 749 09 47  
Email: [copyright@iso.org](mailto:copyright@iso.org)  
Website: [www.iso.org](http://www.iso.org)

Published in Switzerland

# Contents

	Page
Foreword .....	iv
Introduction .....	v
<b>1 Scope</b> .....	<b>1</b>
<b>2 Normative references</b> .....	<b>1</b>
<b>3 Terms and definitions</b> .....	<b>1</b>
<b>4 Apparatus</b> .....	<b>2</b>
<b>5 Washing suspension</b> .....	<b>3</b>
<b>6 Sampling</b> .....	<b>4</b>
<b>7 Test panels</b> .....	<b>4</b>
<b>8 Procedure</b> .....	<b>4</b>
<b>9 Evaluation</b> .....	<b>5</b>
<b>10 Precision</b> .....	<b>5</b>
10.1 Repeatability limit <i>r</i> .....	5
10.2 Reproducibility limit, <i>R</i> .....	5
<b>11 Test report</b> .....	<b>5</b>
<b>Annex A (normative) Verification and calibration of the washing equipment</b> .....	<b>7</b>

(standards.iteh.ai)

[ISO 20566:2020](https://standards.iteh.ai/catalog/standards/sist/fe1489ed-6805-46c5-8633-e8c61dc478d7/iso-20566-2020)

<https://standards.iteh.ai/catalog/standards/sist/fe1489ed-6805-46c5-8633-e8c61dc478d7/iso-20566-2020>

## Foreword

ISO (the International Organization for Standardization) is a worldwide federation of national standards bodies (ISO member bodies). The work of preparing International Standards is normally carried out through ISO technical committees. Each member body interested in a subject for which a technical committee has been established has the right to be represented on that committee. International organizations, governmental and non-governmental, in liaison with ISO, also take part in the work. ISO collaborates closely with the International Electrotechnical Commission (IEC) on all matters of electrotechnical standardization.

The procedures used to develop this document and those intended for its further maintenance are described in the ISO/IEC Directives, Part 1. In particular, the different approval criteria needed for the different types of ISO documents should be noted. This document was drafted in accordance with the editorial rules of the ISO/IEC Directives, Part 2 (see [www.iso.org/directives](http://www.iso.org/directives)).

Attention is drawn to the possibility that some of the elements of this document may be the subject of patent rights. ISO shall not be held responsible for identifying any or all such patent rights. Details of any patent rights identified during the development of the document will be in the Introduction and/or on the ISO list of patent declarations received (see [www.iso.org/patents](http://www.iso.org/patents)).

Any trade name used in this document is information given for the convenience of users and does not constitute an endorsement.

For an explanation of the voluntary nature of standards, the meaning of ISO specific terms and expressions related to conformity assessment, as well as information about ISO's adherence to the World Trade Organization (WTO) principles in the Technical Barriers to Trade (TBT), see [www.iso.org/iso/foreword.html](http://www.iso.org/iso/foreword.html).

This document was prepared by Technical Committee ISO/TC 35, *Paints and varnishes*, Subcommittee SC 9, *General test methods for paints and varnishes*, in collaboration with the European Committee for Standardization (CEN) Technical Committee CEN/TC 139 *Paints and varnishes*, in accordance with the Agreement on technical cooperation between ISO and CEN (Vienna Agreement).

This third edition cancels and replaces the second edition (ISO 20566:2013), which has been technically revised. The main changes compared to the previous edition are as follows:

- the term “control panel” has been changed to “reference panel”;
- the requirement for the temperature of the washing suspension has been deleted;
- verification using a plastics panel has been added to [Annex A](#);
- the text has been editorially revised and the normative references have been updated.

Any feedback or questions on this document should be directed to the user's national standards body. A complete listing of these bodies can be found at [www.iso.org/members.html](http://www.iso.org/members.html).

## Introduction

With this test procedure, it is important to note that the test results will not, over time, remain constant, as a result of changes to the brush material. As the brush ages, the test will become more severe. As a result, the test procedure is suitable only for comparative tests carried out at any one time and using relatively short runs. Readings obtained using equipment which has accumulated different total numbers of operating hours are not comparable with each other.

## iTeh STANDARD PREVIEW (standards.iteh.ai)

[ISO 20566:2020](https://standards.iteh.ai/catalog/standards/sist/fc1489ed-6805-46c5-8633-e8c61dc478d7/iso-20566-2020)

<https://standards.iteh.ai/catalog/standards/sist/fc1489ed-6805-46c5-8633-e8c61dc478d7/iso-20566-2020>

**iTeh STANDARD PREVIEW**  
**(standards.iteh.ai)**

ISO 20566:2020

<https://standards.iteh.ai/catalog/standards/sist/fc1489ed-6805-46c5-8633-e8c61dc478d7/iso-20566-2020>

# Paints and varnishes — Determination of the scratch resistance of a coating system using a laboratory-scale car-wash

## 1 Scope

This document specifies a test procedure for assessing the scratch resistance of organic paint coatings, in particular paint coatings used in the automotive industry (i.e. for assessing their car-wash resistance). Machine-based washing is simulated in the laboratory environment using a rotating brush and synthetic dirt. The test conditions have been designed to be as close as possible to the real conditions in a car-wash. If the test parameters are suitably chosen, the method can also be used for testing protective plastics films and plastics components.

## 2 Normative references

The following documents are referred to in the text in such a way that some or all of their content constitutes requirements of this document. For dated references, only the edition cited applies. For undated references, the latest edition of the referenced document (including any amendments) applies.

ISO 1513, *Paints and varnishes — Examination and preparation of test samples*

ISO 2813, *Paints and varnishes — Determination of gloss value at 20°, 60° and 85°*

ISO 4618, *Paints and varnishes — Terms and definitions*

ISO 4628-1, *Paints and varnishes — Evaluation of degradation of coatings — Designation of quantity and size of defects, and of intensity of uniform changes in appearance — Part 1: General introduction and designation system*

ISO 13076, *Paints and varnishes — Lighting and procedure for visual assessments of coatings*

ISO 13803, *Paints and varnishes — Determination of haze on paint films at 20°*

ISO 15528, *Paints, varnishes and raw materials for paints and varnishes — Sampling*

ISO 18314-1, *Analytical colorimetry — Part 1: Practical colour measurement*

## 3 Terms and definitions

For the purposes of this document, the terms and definitions given in ISO 4618 and the following apply.

ISO and IEC maintain terminological databases for use in standardization at the following addresses:

- ISO Online browsing platform: available at <https://www.iso.org/obp>
- IEC Electropedia: available at <http://www.electropedia.org/>

### 3.1

#### **double pass**

single back-and-forward movement of the test panel holder

### 3.2

#### **test area**

area which is evaluated

**3.3  
reflow effect**

ability of the coating surface to revert to its original appearance after damage such as scratching

**4 Apparatus**

The apparatus<sup>1)</sup> shall comprise at least the following individual components:

**4.1 Washing brush:**

Diameter	(1 000 ± 40) mm
Width	min. 300 mm, typically 400 mm
Material	polyethylene
Profile	x-shaped, spliced
Bristle thickness	(0,8 ± 0,2) mm
Bristle length	(440 ± 20) mm visible
Penetration depth	(100 ± 20) mm (see <a href="#">Figure 1</a> )
Speed of brush rotation	(127 ± 5) min <sup>-1</sup> , in the direction opposite to the direction of travel of the test panel holder

The replacement of washing brushes is decided by testing a reference panel. The reference panel material shall be chosen to reflect changes in the washing brush, so that it is possible to differentiate between a new and a used brush.

The apparatus shall be calibrated as described in [Annex A](#) using a reference panel, either the plastics panel described in [A.1.2](#) or a panel coated with a black non-metallic paint and a clear coat on top as described in [A.1.3](#).

**4.2 Spray nozzles, made of stainless steel:**

Spread of jet	65°
Rate of flow of washing suspension	(2,2 ± 0,2) l/min at (300 ± 50) kPa

The two nozzles shall spray alternately, against the direction of travel of the test panel holder. They shall produce the specified spray pattern (see [Annex A](#)).

1) Information on procuring the test apparatus is available at: DIN Deutsches Institut für Normung e.V., NAB, Burggrafenstrasse 6, 10787 Berlin, Germany.



### 4.3 Test panel holder:

Feed speed (5,0 ± 0,2) m/min

Pattern of movement If the brush is rotating clockwise, the right nozzle is spraying and the test panel holder travels from left to right (and vice versa) — see [Figure 1](#).

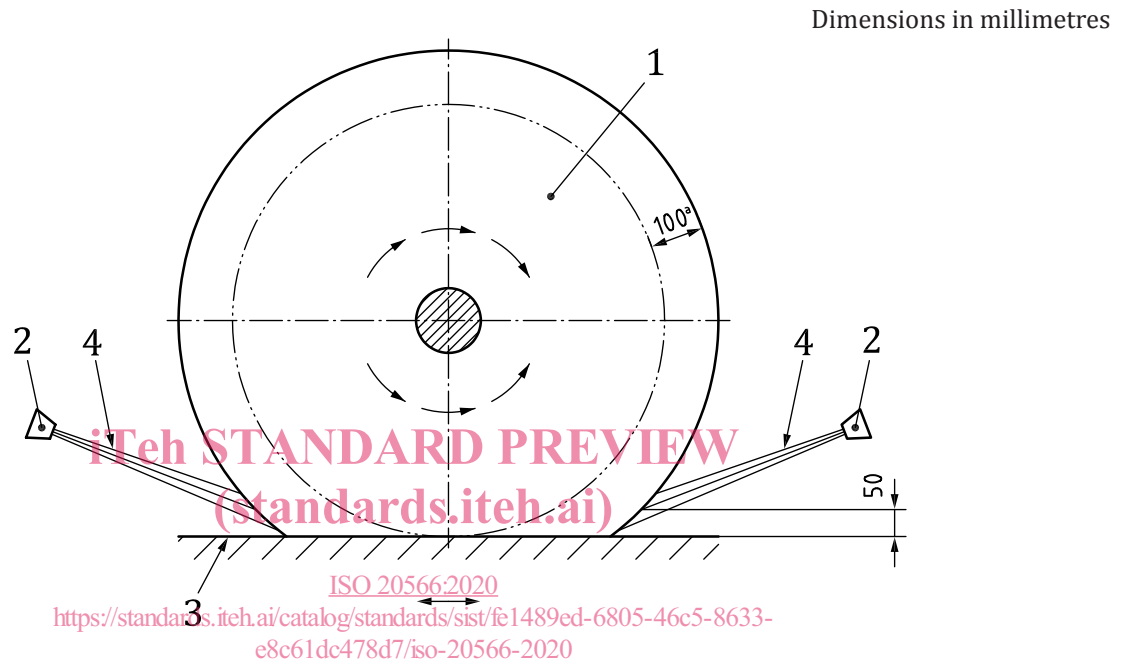

#### Key

- 1 washing brush
- 2 spray nozzle
- 3 test panel holder
- 4 spray jet (centreline of jet strikes brush directly, 50 mm above test panel holder)
- a Penetration depth.

**Figure 1 — Pattern of movement of washing brush and spray nozzles with respect to test panel holder**

**4.4 Container**, suitable for holding the washing suspension during the test.

**4.5 Glossmeter** in accordance with ISO 2813.

## 5 Washing suspension

Prepare a suspension consisting of (1,50 ± 0,05) g of silica powder (silica micro-powder having a mean particle size  $d_{50\%}$  of 24 µm)<sup>2)</sup> per litre of tap water in a suitable container, mixing it by stirring vigorously.

2) Information on procuring the silica powder is available from: DIN Deutsches Institut für Normung e.V., NAB, Burggrafenstrasse 6, 10787 Berlin, Germany.