



Designation: A881/A881M – 10

# Standard Specification for Steel Wire, Indented, Low-Relaxation for Prestressed Concrete Railroad Ties<sup>1</sup>

This standard is issued under the fixed designation A881/A881M; the number immediately following the designation indicates the year of original adoption or, in the case of revision, the year of last revision. A number in parentheses indicates the year of last reapproval. A superscript epsilon ( $\epsilon$ ) indicates an editorial change since the last revision or reapproval.

## 1. Scope\*

1.1 This specification covers uncoated, indented, low-relaxation steel wire for use as prestressing tendons in concrete railroad ties.

1.2 The values stated in either inch-pound units or SI units are to be regarded separately as standard. Within the text, the SI units are shown in brackets. The values stated in each system may not be exact equivalents; therefore, each system shall be used independently of the other. Combining values from the two systems may result in non-conformance with the standard.

## 2. Referenced Documents

2.1 *ASTM Standards*:<sup>2</sup>

A370 Test Methods and Definitions for Mechanical Testing of Steel Products

A421/A421M Specification for Uncoated Stress-Relieved Steel Wire for Prestressed Concrete

A700 Practices for Packaging, Marking, and Loading Methods for Steel Products for Shipment (Withdrawn 2014)<sup>3</sup>

E328 Test Methods for Stress Relaxation for Materials and Structures

2.2 *U.S. Military Standards*:<sup>4</sup>

MIL-STD-129 Marking for Shipment and Storage

2.3 *U.S. Federal Standard*:<sup>4</sup>

Fed. Std. No. 123 Marking for Shipment (Civil Agencies)

## 3. Terminology

3.1 *Definitions of Terms Specific to This Standard*:

<sup>1</sup> This specification is under the jurisdiction of ASTM Committee A01 on Steel, Stainless Steel and Related Alloys and is the direct responsibility of Subcommittee A01.05 on Steel Reinforcement.

Current edition approved Dec. 1, 2010. Published January 2011. Originally approved in 1990. Last previous edition approved in 2005 as A881/A881M – 05. DOI: 10.1520/A0881\_A0881M-10.

<sup>2</sup> For referenced ASTM standards, visit the ASTM website, www.astm.org, or contact ASTM Customer Service at service@astm.org. For *Annual Book of ASTM Standards* volume information, refer to the standard's Document Summary page on the ASTM website.

<sup>3</sup> The last approved version of this historical standard is referenced on www.astm.org.

<sup>4</sup> Available from Standardization Documents Order Desk, DODSSP, Bldg. 4, Section D, 700 Robbins Ave., Philadelphia, PA 19111-5098, http://dodssp.daps.dla.mil.

3.1.1 *indented steel wire for railroad ties, n*—indented, cold-drawn, uncoated, low-relaxation wire intended for use as prestressing tendons in concrete railroad ties, the wire surface having indentations that reduce longitudinal movement of the wire while also providing consistent prestress transfer length.

3.1.2 *low-relaxation wire, n*—indented cold-drawn wire, straightened, that receives a suitable continuous thermo-mechanical treatment as the last operation to produce the properties listed.

## 4. Ordering Information

4.1 It shall be the responsibility of the purchaser to specify all requirements that are necessary for material ordered to this specification. Such requirements shall include, but are not limited to, the following:

4.1.1 Quantity (weight [mass]),

4.1.2 Name of material (indented, low-relaxation steel wire for prestressed concrete railroad ties),

4.1.3 Required minimum tensile strength (see Table 1),

4.1.4 Nominal diameter,

4.1.5 Packaging,

4.1.6 ASTM designation and year of issue, and

4.1.7 Special requirements (such as, indentation sidewall angle or outside inspection), if any.

## 5. Materials and Manufacture

5.1 The steel shall be made by the electric-arc furnace, basic-oxygen, or open-hearth process.

5.2 The base metal shall be carbon steel of such quality that when drawn to wire, indented, and then thermo-mechanically treated, shall have the properties and characteristics prescribed in this specification.

## 6. Mechanical Property Requirements

6.1 *General*—Indented wire shall be supplied in coils, packs, or spools to the specified mechanical properties in Table 1. It shall be permissible to furnish diameters of wire not specifically itemized in this specification, provided that the strength is defined and they conform otherwise to the requirements of this specification.

6.2 *Tensile Strength*—The minimum tensile strength of the indented wire shall conform to the requirements of Table 1.

\*A Summary of Changes section appears at the end of this standard

**TABLE 1 Tensile Strength Requirements**

Nominal Diameter		Tensile Strength		Nominal Area <sup>A</sup>		Nominal Weight [Mass], lb/1000 ft [g/m]
in.	[mm]	lbf	[kN]	in. <sup>2</sup>	[mm <sup>2</sup> ]	
0.198	[5.03]	7230	[32.2]	0.0308	[19.86]	104.8 [155.9]
0.198	[5.03]	7700	[34.3]	0.0308	[19.86]	104.8 [155.9]
0.2094	[5.32]	9000	[39.1]	0.0344	[22.23]	117.1 [174.5]

<sup>A</sup> The nominal cross-sectional area is based on the nominal diameter. The actual average area in in.<sup>2</sup> [mm<sup>2</sup>] may be calculated by dividing the mass (weight) per linear in. [mm] of the specimen in lb [kg] by 0.2836 (weight of 1 in.<sup>3</sup> of steel) [7.850 × 10<sup>-6</sup> kg/mm<sup>3</sup> (mass of 1 mm<sup>3</sup> of steel)]. The amount of variation is dependent on the shape and character of the indentations.

Other values of tensile strength and nominal diameters can be specified if shown by test that the strength exceeds that specified. The tension test shall be made in accordance with Test Methods **A370**.

**6.3 Load at 1 % Extension**—The load at 1 % extension shall be at least 90 % of the minimum specified tensile strength when tested in accordance with Test Methods **A370**.

**6.4 Elongation**—The percent elongation after fracture on a 10-in. [250-mm] gage length shall be 3.0 % minimum.

**6.5 Bend Test**—A 90 degree bend test (see **Fig. 1**) around a pin six times the nominal diameter of the wire shall be performed once per pack/coil for each row of indentations, with the centerline of the row of indentations located at the

outside of the bend. The wire shall be bent at a uniform rate, with the duration of test to be between 10 and 30 seconds. The bend location along the axis of the wire specimen shall be random and three locations shall be tested along the specimen, for a total of nine bends per test. Each bend shall be inspected after testing to ensure no cracking or breaking occurred.

**6.6 Relaxation**—Relaxation properties shall be provided at least annually from records of tests on finished wire. Additional relaxation tests shall be conducted if there is a change in raw rod supply or type. Tests to satisfy this requirement shall comply with the conditions of Supplementary Requirement S6 of Specification **A421/A421M**. The relaxation losses are not to exceed 3.5 % after 1000 hours when tested at an initial load of 80 % of minimum tensile strength.

**7. Requirements for Indentations**

**7.1 Indentations**—Indentations shall be in three lines spaced uniformly around the wire with one line of indentations inclined in the opposite direction to the other two. The indentations shall be placed in respect to the axis of the wire so that the included angle is not less than 45°, as shown in **Fig. 2**. Pitch and shape shall be consistent, with not more than 10 % being malformed in any 2 ft [600 mm] length of wire, judged visually. Criteria for what constitutes a malformed indentation shall be mutually agreed upon between manufacturer and purchaser as required.

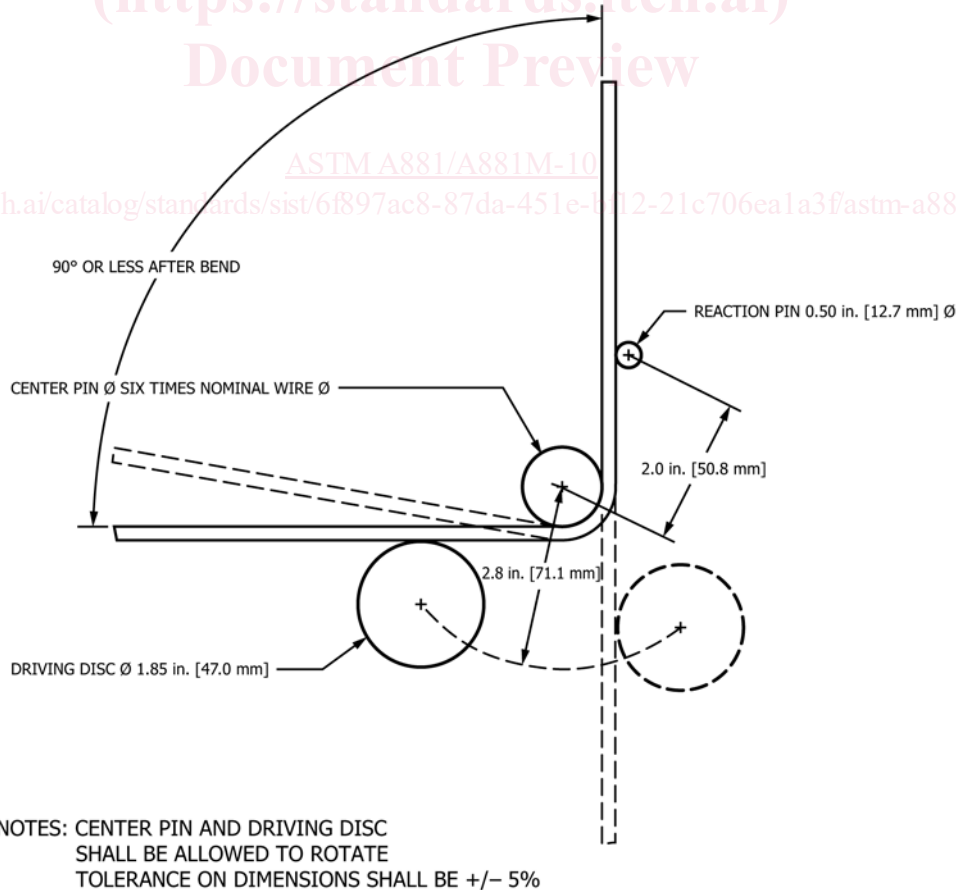

NOTES: CENTER PIN AND DRIVING DISC SHALL BE ALLOWED TO ROTATE  
TOLERANCE ON DIMENSIONS SHALL BE +/- 5%

**FIG. 1 Bend Test Configuration**