



Designation: C1554 – 11

Standard Guide for Materials Handling Equipment for Hot Cells¹

This standard is issued under the fixed designation C1554; the number immediately following the designation indicates the year of original adoption or, in the case of revision, the year of last revision. A number in parentheses indicates the year of last reappraisal. A superscript epsilon (ϵ) indicates an editorial change since the last revision or reappraisal.

1. Scope

1.1 Intent:

1.1.1 This guide covers materials handling equipment used in hot cells (shielded cells) for the processing and handling of nuclear and radioactive materials. The intent of this guide is to aid in the selection and design of materials handling equipment for hot cells in order to minimize equipment failures and maximize the equipment utility.

1.1.2 It is intended that this guide record the principles and caveats that experience has shown to be essential to the design, fabrication, installation, maintenance, repair, replacement, and decontamination and decommissioning of materials handling equipment capable of meeting the stringent demands of operating, dependably and safely, in a hot cell environment where operator visibility is limited due to the radiation exposure hazards.

1.1.3 This guide may apply to materials handling equipment in other radioactive remotely operated facilities such as suited entry repair areas and canyons, but does not apply to materials handling equipment used in commercial power reactors.

1.1.4 This guide covers mechanical master-slave manipulators and electro-mechanical manipulators, but does not cover electro-hydraulic manipulators.

1.2 Applicability:

1.2.1 This guide is intended to be applicable to equipment used under one or more of the following conditions:

1.2.1.1 The materials handled or processed constitute a significant radiation hazard to man or to the environment.

1.2.1.2 The equipment will generally be used over a long-term life cycle (for example, in excess of two years), but equipment intended for use over a shorter life cycle is not excluded.

1.2.1.3 The equipment can neither be accessed directly for purposes of operation or maintenance, nor can the equipment be viewed directly, for example, without shielded viewing windows, periscopes, or a video monitoring system.

1.3 User Caveats:

1.3.1 This standard is not a substitute for applied engineering skills, proven practices and experience. Its purpose is to provide guidance.

1.3.1.1 The guidance set forth in this standard relating to design of equipment is intended only to alert designers and engineers to those features, conditions, and procedures that have been found necessary or highly desirable to the design, selection, operation and maintenance of reliable materials handling equipment for the subject service conditions.

1.3.1.2 The guidance set forth results from discoveries of conditions, practices, features, or lack of features that were found to be sources of operational or maintenance problems, or causes of failure.

1.3.2 This standard does not supersede federal or state regulations, or both, or codes applicable to equipment under any conditions.

1.3.3 This standard does not cover design features of the hot cell, for example, windows, drains, and shield plugs. This standard does not cover pneumatic or hydraulic systems. Refer to Guides C1533, C1217, and ANS Design Guides for Radioactive Material Handling Facilities & Equipment for information and references to design features of the hot cell and other hot cell equipment.

1.3.4 *This standard does not purport to address all of the safety concerns, if any, associated with its use. It is the responsibility of the user of this standard to establish appropriate safety and health practices, and determine the applicability of regulatory limitations prior to use.*

2. Referenced Documents

2.1 *Industry and National Consensus Standards*—Nationally recognized industry and consensus standards applicable in whole or in part to the design, fabrication, and installation of equipment are referenced throughout this guide and include, but are not limited to, the following:

*2.2 ASTM Standards:*²

[C859 Terminology Relating to Nuclear Materials](#)

[C1217 Guide for Design of Equipment for Processing Nuclear and Radioactive Materials](#)

¹ This guide is under the jurisdiction of ASTM Committee C26 on Nuclear Fuel Cycle and is the direct responsibility of Subcommittee C26.14 on Remote Systems.

Current edition approved Feb. 1, 2011. Published February 2011. Originally approved in 2003. Last previous edition approved in 2003 as C1554–03. DOI: 10.1520/C1554-11.

² For referenced ASTM standards, visit the ASTM website, www.astm.org, or contact ASTM Customer Service at service@astm.org. For *Annual Book of ASTM Standards* volume information, refer to the standard's Document Summary page on the ASTM website.

- C1533 Guide for General Design Considerations for Hot Cell Equipment
- C1572 Guide for Dry Lead Glass and Oil-Filled Lead Glass Radiation Shielding Window Components for Remotely Operated Facilities
- C1615 Guide for Mechanical Drive Systems for Remote Operation in Hot Cell Facilities
- C1661 Guide for Viewing Systems for Remotely Operated Facilities

2.3 Other Standards:

- AAI A14.3 Ladders, Fixed Safety Requirements, OSHA³
- ANS 8.1 Nuclear Criticality Safety in Operations with Fissile Materials Outside Reactors⁴
- ANS Design Guides for Radioactive Material Handling Facilities & Equipment, ISBN: 0-89448-554-7⁴
- ASSE SA/SAFE Ladders, Fixed Safety Requirements, OSHA⁴
- ANSI B30.2 Overhead and Gantry Cranes⁵
- ASME NQA 1 Quality Assurance Requirements for Nuclear Facility Applications⁶
- ASME NOG-1 Rules for Construction of Overhead Gantry Cranes (Top-Running Bridge, Multiple Girder)⁶
- ISO/TC 85/SC 2 N 637 E Remote Handling Devices for Radioactive Materials—Part 1 : General Requirements⁷
- ISO 9001 Quality Management Systems Requirements⁷
- NEMA 250 Enclosures for Electrical Equipment 1000 Volts Maximum (Type 4)⁸
- NFPA 70 National Electric Code⁹
- 2.4 Federal Regulations:¹⁰
- 10CFR50 Appendix B, Quality Assurance
- 10CFR830.120 Nuclear Safety Management Quality Assurance Requirements
- 29CFR1910 Occupational Safety and Health Standards
- 40CFR 260-279 Solid Waste Regulations

3. Terminology

3.1 Definitions:

- 3.1.1 The terminology employed in this guide conforms with industry practice insofar as practicable.
- 3.1.2 For definitions of general terms used to describe hot cells and hot cell equipment, refer to Terminology C859, and Guide C1533.

³ Available from U.S. Government Printing Office Superintendent of Documents, 732 N. Capitol St., NW, Mail Stop: SDE, Washington, DC 20401, <http://www.access.gpo.gov>.

⁴ Available from American Nuclear Society, 555 North Kensington Ave., La Grange Park, IL 60525, (312) 352-6611.

⁵ Available from American National Standards Institute (ANSI), 25 W. 43rd St., 4th Floor, New York, NY 10036, <http://www.ansi.org>.

⁶ Available from American Society of Mechanical Engineers (ASME), ASME International Headquarters, Three Park Ave., New York, NY 10016-5990, <http://www.asme.org>.

⁷ Available from International Organization for Standardization (ISO), 1, ch. de la Voie-Creuse, Case postale 56, CH-1211, Geneva 20, Switzerland, <http://www.iso.ch>.

⁸ Available from Global Engineering Documents, 15 Inverness Way, East Englewood, CO 80112-5704, <http://www.global.ihs.com>.

⁹ Available from National Fire Protection Association (NFPA), 1 Batterymarch Park, Quincy, MA 02169-7471, <http://www.nfpa.org>.

¹⁰ Available from U.S. Government Printing Office Superintendent of Documents, 732 N. Capitol St., NW, Mail Stop: SDE, Washington, DC 20401, <http://www.access.gpo.gov>.

3.1.3 *bogie*—a bogie is a small cart used to move material, supplies and small tools into, out of and within a hot cell.

3.1.4 *boot*—boot in this context refers to a flexible covering over equipment including a manipulator to protect it from radioactive contamination.

3.1.4.1 *Discussion*—The boot may also protect the equipment or manipulator from acid, caustic solutions and abrasive powders.

3.1.5 *Cartesian coordinate system*—a three-dimensional coordinate system in which the coordinates of a point in space are its distances from each of three intersecting, mutually perpendicular, planes along lines parallel to the intersection of the other two. Usually referred to as *X*, *Y*, and *Z*.

3.1.6 *coordinated control*—control of a manipulator that allows multiple axes of the manipulator to be automatically controlled to achieve a special motion of the wrist or end effector. These motions can be straight-line motion of the wrist or end effector, rotation about a point, movement in Cartesian coordinates or other motions at the wrist or end effector requiring relative motion of more than one joint.

3.1.7 *deadhead*—the act of placing a force on an immovable object or component.

3.1.8 *electro-hydraulic manipulator*—a remotely operated lifting device usually mounted on a crane bridge, wall, pedestal, or ceiling and is used to handle heavy equipment in a hot cell. Each joint of the E/M is operated by an electric motor or electric actuator. The E/M is operated using controls from the uncontaminated side of the hot cell. Most E/Ms have lifting capacities of 45 kg (100 lb) or more.

3.1.9 *electro-mechanical manipulator (E/M), n*—a remotely operated device used to move and manipulate materials and devices within a hot cell.

3.1.10 *end effector*—an end effector is a gripper or other device or tool on the end (wrist) of a slave of a master-slave or power manipulator.

3.1.11 *force ball*—a force ball is an input device in the shape of a sphere that provides signals relative to force or torques, or both, placed on the ball by an operator. The signals are usually segregated into forces and torques in different directions, usually Cartesian, even though the operator input is generally in a combination of directions.

3.1.12 *force feedback*—force feedback is an electrical signal relative to force sensed, usually at a joint of a manipulator. Force feedback is commonly used to generate a force at the master that is relative to the sensed force on the end effector.

3.1.13 *force reflection*—force reflection is the perception of force at the master of a master-slave manipulator that is relative to the forces applied at the end effector.

3.1.14 *gray (Gy), [L²T⁻²], n*—gray is the unit of measure of absorbed dose (1 J/kg).

3.1.15 *hot cell, n*—an isolated, shielded containment that provides a controlled environment and is designed to safely handle radioactive and typically contaminated material without recourse to routine human access.

3.1.15.1 *Discussion*—The radiation levels within a hot cell

are typically 1 Gy/h (100 rads per hour) or higher. See Guide **C1533** for more detail.

3.1.16 *master-slave manipulator (MSM), n*—a device to remotely handle items, tools, or radioactive material in a hot cell.

3.1.16.1 *Discussion*—The operator controls the “master” and the follower, or “slave,” replicates its movements to handle the material in the hot cell. The mechanical connection is made with metal tapes or cables. MSMs typically have lifting capacities of 9 to 23 kg (20 to 50 lb).

3.1.17 *moused hook*—a moused hook is a lifting hook on a crane that has a latch (mouse) across the mouth of the hook. The latch keeps the cable, bail or other device within the hook so that it can not accidentally slide off of the hook. The latch is manually activated to release the cable, bail or other device from the hook. Moused hooks are not used in hot cells because of the inability to manually release the latch.

3.1.18 *pendant*—a pendant is a box with switches, buttons, other controls and sometimes a small display screen used to control equipment including manipulators and cranes. The pendant usually has a cable or umbilical cord to transmit signals from and to the pendant. Some pendants transmit and receive signals over radio frequencies, so they don’t require an umbilical cord.

3.1.19 *power manipulator*—a manipulator with joints activated electrically or hydraulically. See electro-hydraulic manipulator and electro-mechanical manipulator.

3.1.20 *through-the-wall sleeve*—a through-the-wall sleeve is a pipe, open at both ends, embedded in the shield wall of a hot cell into which the manipulator is inserted. A window is generally placed below the sleeve(s) to provide the operator a view of the manipulator(s).

4. Significance and Use

4.1 Materials handling equipment operability and long-term integrity are concerns that originate during the design and fabrication sequences. Such concerns are most efficiently addressed during one or the other of these stages. Equipment operability and integrity can be compromised during handling and installation sequences. For this reason, the subject equipment should be handled and installed under closely controlled and supervised conditions.

4.2 This guide is intended as a supplement to other standards (Section 2, Referenced Documents), and to federal and state regulations, codes, and criteria applicable to the design of equipment intended for this use.

4.3 This guide is intended to be generic and to apply to a wide range of types and configurations of materials handling equipment.

4.4 The term *materials handling equipment* is used herein in a generic sense. It includes manipulators, cranes, carts or bogies, and special equipment for handling tools and material in hot cells.

4.5 This service imposes stringent requirements on the quality and the integrity of the equipment, as follows:

4.5.1 Boots and similar protective covers should not restrict movement of the equipment, should be properly sealed to the equipment and should withstand the radiation, cell atmosphere, dust, cell temperatures, chemical exposures, and cleaning and decontamination reagents, and also resist snags and tearing.

4.5.2 Materials handling equipment should be capable of withstanding rigorous chemical cleaning and decontamination procedures.

4.5.3 Materials handling equipment should be designed and fabricated to remain dimensionally stable throughout its life cycle.

4.5.4 Attention to fabrication tolerances is necessary to allow the proper fit-up between components for the proper installation and mounting of materials handling equipment in hot cells, for example, when parts or components are being replaced. Fabrication tolerances should be controlled to provide sufficiently loose fits where possible to aid in remote maintenance and replacement of equipment and components.

4.5.5 Fabrication materials should be resistant to radiation damage, or materials subject to such damage should be shielded or placed and attached so as to be readily replaceable.

4.5.6 Smooth surface finishes are necessary for decontamination reasons. Irregularities that hide and retain radioactive particulates or other adherent contamination should be eliminated or minimized.

4.6 Materials handling equipment that is exposed to high temperatures, pressures, acidic or caustic conditions may require special design considerations to be compatible with the operating environment. Potential rates of change for temperature and pressure as well as absolute temperature and pressure extremes, created by activation of fire suppression systems and other emergency systems, should be considered.

4.7 When replacing, modifying or adding additional materials handling equipment to an existing hot cell, maintenance records of materials handling equipment in that hot cell or in a hot cell having a similar processing mission may be available for reference. These records may offer valuable insight with regard to the causes, frequency, and type of failure experienced for the type and class of equipment being designed and engineered, so that improvements can be made in the new equipment.

4.8 Preventive maintenance based on previous experience in similar environments and similar duty should be performed to prevent unscheduled repair of failed components.

5. Quality Assurance and Quality Requirements

5.1 The owner-operator should administer a quality assurance program approved by the agency of jurisdiction. QA programs may be required to comply with 10CFR50 Appendix B, 10CFR830.120 Subpart A, ASME NQA-1, or ISO 9001.

5.2 The owner-operator should require appropriate quality assurance of purchased materials handling equipment and components to assure proper fit up, operation and reliability of the equipment in the hot cell.

6. General Requirements

6.1 *Design Caveat:*

6.1.1 Only the minimum amount of materials handling equipment should be placed in a hot cell to allow safe and efficient operation. Unnecessary materials handling equipment in a cell adds to the cost of operating and maintaining the cell and add to the eventual decontamination and disposal costs of equipment in the cell. A thorough review of the materials handling equipment necessary to perform the hot cell operations should be performed prior to introducing radioactive materials into a new hot cell.

6.1.2 All hot cell equipment should be handled with extreme care using the materials handling equipment during transfer handling and installation sequences to ensure against collision damage.

6.1.3 Installation sequences should be planned and sequenced so that other equipment is not handled above and around previously installed components to the extent practicable.

7. Materials of Construction

7.1 *General Considerations for Metals and Alloys:*

7.1.1 It is desirable that corrosion resistant alloys or metals be used for all material handling equipment in this service. The advantages of corrosion resistant alloys or metals should be considered against their increased cost and availability. Refer to Materials of Construction in Guide [C1533](#).

7.1.2 In many cases, it is not possible to substitute a corrosion resistant metal for one that isn't corrosion resistant, such as in the case of structural members or commercial components. Consideration should be given to painting those items. Refer to Guide [C1533](#).

7.2 *General Considerations for Plastics and Other Materials:*

7.2.1 Plastics, elastomers, oils, grease, resins, bonding agents, solid-state devices, wire insulation, thermal insulation materials, paints, coatings, and other materials are subject to radiation damage and possible abrupt failure. Not all such materials and components can be excluded from service in the subject environment. Their use should be carefully considered. Refer to Guide [C1533](#).

8. Equipment

8.1 Materials handling equipment should be designed or modified in a way that will extend the service life of the equipment, reduce failures, and improve maintainability. The installation position, the orientation, and the attachment methods should be such as to simplify removal and replacement of mechanical equipment susceptible to periodic or unpredictable failure or outage.

9. Mechanical Equipment

9.1 Specific mechanical equipment is covered in Section 11 of this standard guide.

10. Instrumentation

10.1 Where practical and beneficial, equipment used for handling nuclear and radioactive materials should be equipped with instrument sensor components, circuitry, readout, control,

and alarm elements that allow continuous and precise monitoring and control of the material handling operation.

11. Materials and Equipment Handling/Transport Facilities

11.1 *General:*

11.1.1 Safeguards and procedures should be used with hot cell material handling equipment to avoid nuclear criticality. See ANS 8.1.

11.1.2 Manipulators and cranes, like other hot cell equipment, are subject to radiation damage effects and contamination. Since decontamination and maintenance work is generally carried out remotely or by personnel working in anti-contamination clothing with respiratory protection, the work is tedious, awkward, and time consuming, which can produce significant radiation dose. The materials handling equipment covered in this section should be designed and fabricated to accommodate fast, simple cleanup routines, so that component repair or changeout procedures are simplified. In addition, the use of wash-down rated components should be considered.

11.1.3 Where practicable, crane and manipulator components should be modular in design. In the case of cranes, the hoist motor should be designed to be easily removable from the trolley so that it can be repaired in an area with lower radiation fields. The incell portion of the master-slave manipulators should also be removable so that they can be repaired in a glovebox with lower radiation fields.

11.1.4 Through-the-wall manipulators are operated by means of a direct mechanical linkage between the master and the slave ends. They are operated from behind a shield wall or confinement barrier. Since part of the manipulator is outside the cell, this type of manipulator does not come under the strict definition of "equipment mounted in the hot cell environment," however, this type of manipulator is included in the scope of this guide.

11.1.5 Reliance on the use of master-slave manipulators or any other type of manipulator to bring about or maintain a safe condition in the hot cell is not recommended. This requires having an operable manipulator available on a full-time basis. Manipulators should not be used under conditions that would require their use to initiate, execute, or control equipment or operations that are vital to the safe operation of the facilities in the hot cell.

11.1.6 Electrical design constraints and precautions or suggestions related to viewing capabilities for materials handling equipment as covered in subsequent sections are generally applicable to either a crane or a carriage-mounted manipulator installation.

11.1.7 The use of limit switches and bumpers provides the means of setting limits for the movement of materials handling system components.

11.1.8 Computer program instructions incorporated in the crane or manipulator control system are another means of limiting the movement of materials handling system components. Crane hooks or manipulator arms can be excluded from areas where collisions with or damage to other equipment may occur. The ability to override such pre-programmed limits

should be provided, but only under controlled and supervised conditions. Software limits are not as reliable as hard stops, and are generally incorporated in addition to hard stops to prevent routine use of the hard stops.

11.2 *Mechanical Master-Slave Manipulators:*

11.2.1 Mechanical master-slave manipulators are operated by means of a direct mechanical linkage between the master and the slave ends. They are operated from behind a shield wall or confinement barrier. Note that these manipulators can be removed for maintenance or, when required, replaced in their entirety except for the through-the-wall sleeves.

11.2.2 Through-the-wall and over-the-wall mechanical master-slave manipulators are usually installed side-by-side as a set of two. Multiple sets of this type of manipulator are used to obtain the volumetric coverage required in large hot cells. These manipulators are suited to dexterous handling operations in experimental and laboratory facilities that cannot be accomplished in any other fashion. They are often used in conjunction with batch processing operations involving nuclear or radioactive materials in particulate, granular, or solid form, or when processing steps are conducted in small scale equipment and the process requires physical handling and transfer operations. Because of their dexterity, mechanical master-slave manipulators are also used in large process cells for handling operations, operation and maintenance of in-cell equipment and in handling rigging for in-cell cranes. These manipulators inherently provide some degree of force and torque feedback to the operator. Depending on operator proficiency, these manipulators can be used to perform complex, delicate and precise material handling operations.

11.2.3 Mechanical master-slave manipulators typically use metal tapes or cables to link the master to the slave. The tapes and cables can have long life, but can fail due to fatigue after extended usage, or may fail prematurely due to misuse. Misuse is commonly lifting loads above their rating or shock loads due to collisions or hammering.

11.2.4 Mechanical master-slave manipulators generally have a payload of approximately 20 pounds when fully extended, although heavy-duty units capable of up to 100 pounds are available. Capacities for all manipulators are dependent on the angle of the manipulator while lifting an object. The rated lifting capacity and reach of the master-slave manipulator are important considerations when selecting the type of manipulator for a specific hot cell application.

11.2.5 Mechanical master-slave manipulators have grippers or end effectors with a fixed size and maximum opening. Components in the cell to be manipulated should be compatible with the grippers. See Fig. 1 for an example of one type of gripper dimensions.

11.2.6 Mechanical master-slave manipulators should be installed in pairs to provide maximum handling dexterity, although single manipulators are occasionally used for specific tasks. An operator may use the pair or two operators can cooperate in operations where each operates one manipulator.

11.2.7 Boots or sleeves are available for most mechanical master-slave manipulators. These boots cover the slave arm in order to minimize the contamination on the assembly extending into the hot cell. In dirty, dusty environments boots can

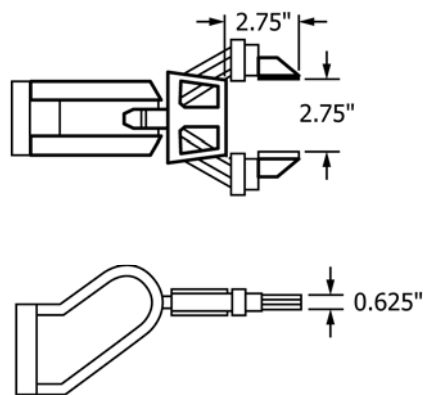

FIG. 1 Typical Gripper Dimensions

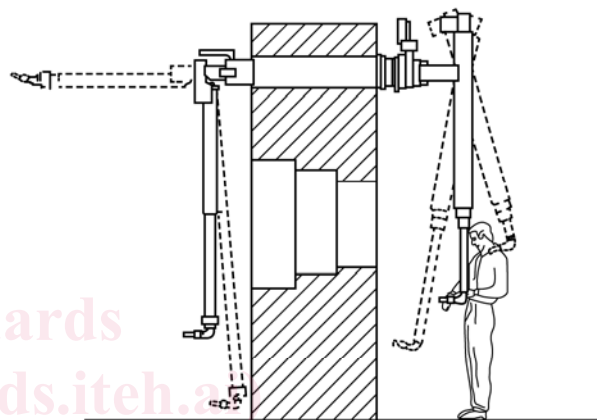

FIG. 2 Typical Mechanical Master-Slave Manipulator

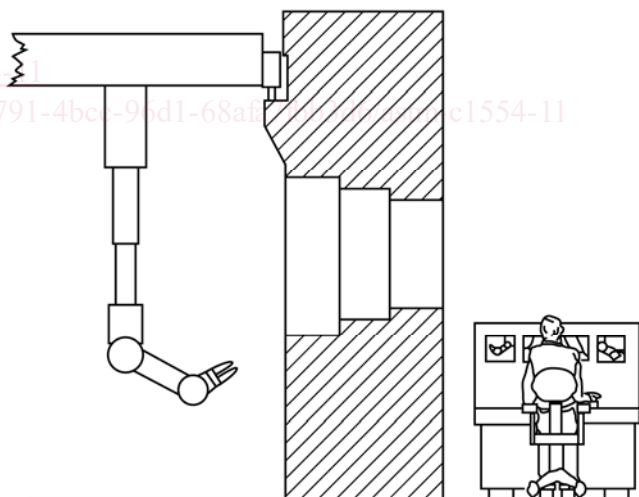

FIG. 3 Typical Power Manipulator on Bridge

keep material out of the manipulator bearings, gears and pulleys, thereby extending time between maintenance and repair. However, the boots can be a nuisance due to their size, weight and restrictions to movement, and can be ripped or torn in operation. Therefore, the use of boots should be considered on a case-by-case basis. In hot cells contaminated with alpha emitting radionuclides, boots are recommended.

11.3 *Power Manipulators:*

11.3.1 Both electric and hydraulic power manipulators are available for service in hot cells. Hydraulic manipulators have been used in radiation environments for short duration applications, but generally are not used for long-term applications. If the hydraulic power pack is located outside the cell, there is concern over potentially contaminated hydraulic fluid, under pressure, being re-circulated outside the cell. The hydraulic power pack is generally not located inside the cell due to the complexity of this equipment and the attendant maintenance and repair of the power pack inside the cell. Since almost all long-term power manipulators used in nuclear service to date are electric, only electric power manipulators are discussed in this guide.

11.3.2 Due to the force they can exert and the speeds at which they can move, power manipulators have the capability to inflict damage in a cell. This potential damage may be to other equipment in the cell and also cell windows. Abrupt physical contact of a manipulator with an internal window surface could result in a cover glass or glass pane fissure or dielectric discharge. Refer to Practice **C1661** and Practice **C1572** for more information regarding hot cell windows. This potential damage to cell windows and equipment can be prevented by limiting the speed of travel, by including slip clutches in drive systems, by placing physical limitations on the work envelope, by providing adequate guards on the equipment or windows, or by using software algorithms that limit the motions of travel.

11.3.3 Power manipulators can have much higher load lifting capacity than mechanical master-slave manipulators. Capacities to lift several hundred pounds are typical. Because the mechanical linkage between the master and slave is not required, the slave can be fixed in any suitable location in the cell or placed on a bridge or carriage to change the slave location in the cell. The master can also be located at a window to allow direct viewing or in any location when video systems are provided.

11.3.4 Electric power manipulators can have only tele-operation capabilities or can have tele-operation capabilities augmented with robotic capabilities. Electric power manipulators with robotic capabilities can have operational advantages over manipulators with only tele-operation because of the coordination of degrees of motion and ease of control. However, manipulators with robotic capabilities require additional components to feed back position and velocity. Therefore, they are more complex, which generally reduces reliability. If designed properly, the manipulators may be operated without feedback (teleoperated) if feedback is lost. The feedback of signals also means that bus bars, if used for power, must be augmented with other means to feedback signals. The operational advantages of robotic capabilities must be weighed against the additional cost, complexity and potentially lower reliability.

11.3.5 Contemporary electric power manipulators are available with coordinated control. Even a push button control, usually on a pendant, can provide straight-line motion relative to the cell coordinates (world) or relative to the wrist (tool). These manipulators can also have hand controls, for example, joysticks and force balls, that can simplify coordination of

multiple joints and can also provide straight-line motion in world or tool coordinates. With coordinated control, other options are also available including setting a maximum speed and rotating about a point. Some power manipulators use a replicate master for control. This provides operation similar to a mechanical master, but does not provide force reflection.

11.3.6 Provision should be made to remotely remove a manipulator for repair or replacement if the manipulator fails with the joint(s) in any position. An alternative is to provide a means for moving a joint by mechanical means in the event of a failure. However, this alternative should be available with all failures including a condition that prevents the axis motor or reducer from turning, or in the case of a failed coupling or shaft.

11.3.7 Force feedback has been provided on some power manipulators. The intent of force feedback is to provide the operator with a “feel” of the task, similar to that provided with normal manual tasks and to that provided with a mechanical master-slave manipulator. Also, force feedback would indicate unintended contact with other equipment or material in the cell and allow the operator to respond appropriately. The ratio and fidelity of the force feedback is critical. Results of the use of force feedback on power manipulators have been mixed. Some results indicate the ability to accomplish more dexterous tasks, such as threading a nut on a screw, and more efficient (faster) task completion. Other results indicate only marginal dexterity increases coupled with a much more complex and, therefore, less reliable system.

11.3.8 Power manipulators with six degrees of freedom in a proper configuration will allow placement of the gripper or end-effector in any position in the manipulator’s work envelope and in any orientation. Power manipulators with fewer than six degrees of freedom may be acceptable for certain applications, but their inability to present the gripper or end-effector in any orientation, or with some configurations in any position, should be completely understood and accepted. Power manipulators on tracks or carriages essentially provide additional degrees of freedom, which can significantly increase the work envelope of a manipulator, and also allow approach from different attitudes, thereby increasing flexibility. The redundancies that these additional degrees of freedom add should be controlled and handled appropriately.

11.3.9 *Fixed Power Manipulators:*

11.3.9.1 Fixed, electric, power manipulators may be mounted on the cell floor or cell walls. They are generally not mounted on cell ceilings due to interference with bridge cranes and the incompatibility with cell covers.

11.3.9.2 Fixed, electric, power manipulators should have power and instrument cables that are designed to be remotely replaceable. The cables should be mounted in such a way that they cannot be contacted or damaged by the manipulator.

11.3.9.3 An alternate to cables in the cell is a power manipulator attached to a through-the-wall tube which contains the cables. This extends cable life, since the cables are not exposed to as much radiation and the cell environment. This also makes cable replacement easier and faster.

11.3.10 *Carriage-Mounted Manipulators:*