



Designation: ~~F526–97 (Reapproved 2003)~~ Designation: F526 – 11

## Standard Test Method for ~~Measuring Dose for Use in Linear Accelerator Pulsed Radiation Effects Tests Using Calorimeters for Total Dose Measurements in Pulsed Linear Accelerator or Flash X-ray Machines~~<sup>1</sup>

This standard is issued under the fixed designation F526; the number immediately following the designation indicates the year of original adoption or, in the case of revision, the year of last revision. A number in parentheses indicates the year of last reapproval. A superscript epsilon ( $\epsilon$ ) indicates an editorial change since the last revision or reapproval.

*This standard has been approved for use by agencies of the Department of Defense.*

### 1. Scope

1.1 This test method covers a calorimetric measurement of the total dose delivered in a single pulse of electrons from an electron linear accelerator or a flash X-ray machine (FXR, e-beam mode) used as an ionizing source in radiation-effects testing. The test method is designed for use with pulses of electrons in the energy range from 10 to 50 MeV and is only valid for cases in which both the calorimeter and the test specimen to be irradiated are “thin” compared to the range of these electrons in the materials of which they are constructed.

1.2 The procedure described can be used in those cases in which (1) the dose delivered in a single pulse is  $5 \text{ Gy} \text{ Gy} (\text{matl})^2$  (500 ~~rad~~rd (matl)) or greater, or (2) multiple pulses of a lower dose can be delivered in a ~~time~~-short ~~time~~ compared to the thermal time constant of the calorimeter. Matl refers to the material of the calorimeter. The minimum dose per pulse that can be acceptably monitored depends on the variables of the particular test, including pulse rate, pulse uniformity, and the thermal time constant of the calorimeter.

1.3 A determination of the total dose is made directly for the material of which the calorimeter block is made. The total dose in other materials can be calculated from this measured value by formulas presented in this test method. The need for such calculations and the choice of materials for which calculations are to be made shall be subject to agreement by the parties to the test.

1.4 The values stated in SI units are to be regarded as the standard. The values in parenthesis are provided for information only.

1.5 *This standard does not purport to address the safety concerns, if any, associated with its use. It is the responsibility of the user of this standard to establish appropriate safety and health practices and determine the applicability of regulatory limitations prior to use.*

### 2. Referenced Documents

2.1 *ASTM Standards:*<sup>3</sup>

E230 ~~Specification and Temperature-Electromotive Force (EMF) Tables for Standardized Thermocouples~~ Specification and Temperature-Electromotive Force (EMF) Tables for Standardized Thermocouples

E1894 Guide for Selecting Dosimetry Systems for Application in Pulsed X-Ray Sources

### 3. Terminology

3.1 *Definitions:*

3.1.1 *device under test (DUT)*—the device that is under the current test.

3.1.2 *thermal time constant of a calorimeter*—the time for the temperature excursion of the calorimeter resulting from a radiation pulse to drop to  $1/e$  of its initial maximum value.

<sup>1</sup> This test method is under the jurisdiction of ASTM Committee F01 on Electronics and is the direct responsibility of Subcommittee F01.11 on Nuclear & Space Radiation Effects.

Current edition approved June 10, 2003. Published March 1998. Originally published as F526–77 T. Last previous edition F526–91. DOI: 10.1520/F0526-97R03 on Nuclear and Space Radiation Effects.

Current edition approved Jan. 1, 2011. Published February 2011. Originally published as F526–77 T. Last previous edition approved in 2003 as F526–97(2003). DOI: 10.1520/F0526-11.

<sup>2</sup> In 1975 the General Conference on Weights and Measures adopted the unit gray (symbol—Gy) for absorbed dose; 1 Gy = 100 rad.

<sup>3</sup> For referenced ASTM standards, visit the ASTM website, [www.astm.org](http://www.astm.org), or contact ASTM Customer Service at [service@astm.org](mailto:service@astm.org). For *Annual Book of ASTM Standards* volume information, refer to the standard’s Document Summary page on the ASTM website.

#### 4. Summary of Test Method

4.1 *Single-Pulse Method*—This method consists of (1) irradiating, with a single pulse of high-energy electrons from an electron linear accelerator (linac) or flash X-ray machine (FXR), a small block of material to which either a thermistor or a thermocouple made from small-diameter wire is attached; (2) recording and measuring the resulting signal from a bridge circuit or directly from the thermocouple; (3) calculating the total dose deposited in the block based on the temperature rise and the specific heat of the material; and (4) if required, calculating the equivalent dose in other specified materials.

4.2 *Multiple-Pulse Method*—If the dose available in a single pulse is not large enough to give measurable results, the linac is pulsed repeatedly within a time short compared to the thermal time constant of the calorimeter. This method is similar to the single-pulse method except that the average dose delivered in each pulse is calculated from the measured cumulative dose of all the pulses.

#### 5. Significance and Use

5.1 An accurate measure of the dose ~~during radiation effects testing~~ is necessary to ensure the validity of the data taken, to enable comparison to be made of data taken at different facilities, and to verify that components or circuits are tested to the radiation specification applied to the system for which they are to be used.

5.2 The primary value of a calorimetric method for measuring dose is that the results are absolute. They are based only on physical properties of materials, that is, the specific heat of the calorimeter-block material and the Seebeck ~~emf~~EMF of the thermocouple used or the temperature coefficient of resistance ( $\alpha$ ) of the thermistor used, all of which can be established with non-radiation measurements.

5.3 The method permits repeated measurements to be made ~~during a radiation effects test~~ without requiring entry into the radiation cell between measurements.

#### 6. Interferences

6.1 *Thermal Isolation*—If the thermal isolation of the calorimeter is not sufficient, the thermal time constant of the calorimeter response will be too short for it to be useful.

NOTE 1—This condition can be caused by insufficient insulation material or by heat loss through the thermocouple wires themselves.

6.2 *Thermal Equilibrium*—The initial value of the transient temperature change following a radiation pulse may not reflect the true temperature change of the calorimeter-block material.

NOTE 2—This situation can be brought about by a temperature rise occurring in the materials at the point of attachment of the thermocouple or the thermistor different from that in the calorimeter-block material. As long as the calorimeter block comprises the great bulk of the calorimeter material, the temperature will quickly equilibrate to that of the block, and the subsequent temperature record will be that of the calorimeter-block material (see Appendix X1).

6.3 *Pulse Reproducibility*—If pulse-to-pulse reproducibility of the radiation source varies more than  $\pm 20\%$ , a good measure of the dose per pulse may not be attainable from the average value calculated in the multiple-pulse method.

6.4 *Facility Spot Size*—If the calorimeter is used in high-dose rate positions, the spot size (especially in ebeam facilities) may not be large enough to adequately cover the calorimeter material.

#### 7. Apparatus

7.1 *Linac*—Electron linear accelerator and associated instrumentation and controls suitable for use as an ionizing source in radiation-effects testing. See Guide E1894.

7.2 *Calorimeter*—Special instrument suitable for measuring the dose delivered by the linac and constructed in accordance with any of several designs utilizing any of several materials as indicated in Appendix X1. Although measurement differences resulting from the use of different designs should not be significant, all parties to the test shall agree to a single design utilizing a single calorimeter-block material and a specific thermocouple or thermistor. The calorimeter design shall be such that the surface density in the beam path is less than or equal to no more than 20 % of the range of the beam-energy electrons (see Fig. 1).

7.3 *D-C Low Noise Amplifier (LNA)*, with a gain of 1000 to 10 000 (see Fig. 2).

NOTE 3—An analog nanovoltmeter with a recorder output can also be used as a low noise amplifier. These devices produce a 1-V output for a full scale reading.

7.3.1 Response time ~~no greater~~less than 0.1 s for the amplifier output to reach 90 % of its final reading,

7.3.2 Noise level less than 10 mV rms referred to the output,

7.3.3 Measurement accuracy of 2 % of full scale or better, and

7.3.4 Normal-mode rejection capability such that ~~a~~eAC voltages of 50 Hz and above and 60 dB greater than the range setting shall affect the instrument reading by less than 2 %.

NOTE 4—If the meter does not have an internal nulling circuit, it may be necessary to use a simple bucking circuit to null out thermal ~~emfs~~EMFs in the measuring circuit to keep the meter on scale at the high-gain positions used in this measurement (see Fig. 1).

7.4 *Data Recorder*—~~Linear-response recorder meeting the following specifications:~~

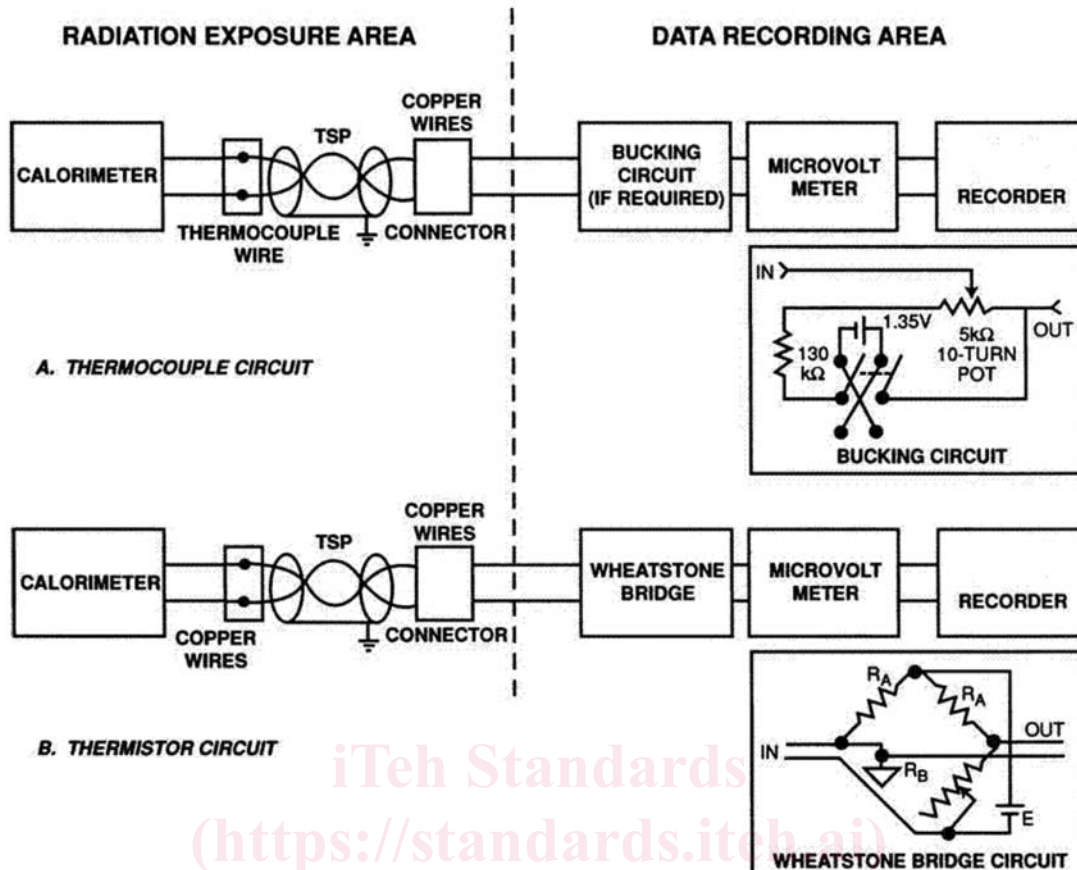

FIG. 1 Typical Block Diagram of Calorimeter Dosimeter Circuit

- 7.4.1 Recording speed sufficient to capture 5 to 10 s of calorimeter response.
- 7.4.2 Response time for full-scale deflection of 0.1 s or less.
- 7.4.3 Deviation of response from linearity of no more than  $\pm 2\%$ , and
- 7.4.4 Sensitivity compatible with the recorder output of the d-c LNA. Typically 2mV full scale. —Linear-response recorder or oscilloscope meeting the following specifications:

7.4.1 Recording duration sufficient to capture 5 to 10 s of calorimeter response.

7.5 Voltage Calibration Source—Voltage source capable of meeting the following specifications:

7.5.1 Output voltages including 1.5, 3.0, 5.0, 10.0, 15, 30, and 50  $\mu\text{V}$ , 50, and 100  $\mu\text{V}$ ,

7.5.2 Accuracy of  $\pm 1\%$  of the selected voltage, or better,

7.5.3 Thermally generated voltages of less than 100 nV with the source stabilized, and

7.5.4 Source resistance of 100  $\Omega$  or less.

7.6 Wheatstone Bridge Circuit, designed so that the thermistor forms one leg of the bridge, and so that the adjustable resistor of the bridge will be equal to the resistance of the thermistor at balance (see Fig. 1B).

7.7 Flash X-ray Machine (E-beam Mode)—An FXR operated in the e-beam mode generally provides a higher dose rate than similar machines operated in photon, for example, bremsstrahlung, mode. However, testing in the e-beam mode requires that appropriate precautions be taken and special test fixtures be used to ensure meaningful results. The beam produces a large magnetic field, which may interfere with the instrumentation, and can induce large circulating currents in device leads and metals. The beam also produces air ionization, induced charge on open leads, and unwanted cable currents and voltages. E-beam testing is generally performed with the device-under-test (DUT) mounted in a vacuum to reduce air ionization effects. Some necessary precautions are:

7.7.1 The electron beam must be constrained to the region that is to be irradiated. Support circuits and components must be properly shielded.

7.7.2 The electron beam must be stopped within the test chamber and returned to the FXR to prevent unwanted currents in cables and secondary radiation in the exposure room.

7.7.3 All cables and wires must be protected from exposure to prevent extraneous currents. These currents may be caused by direct deposition of the beam in cables, or by magnetic coupling of the beams into the cable.

7.7.4 An evacuated chamber for the test is required to reduce the effects of air ionization.

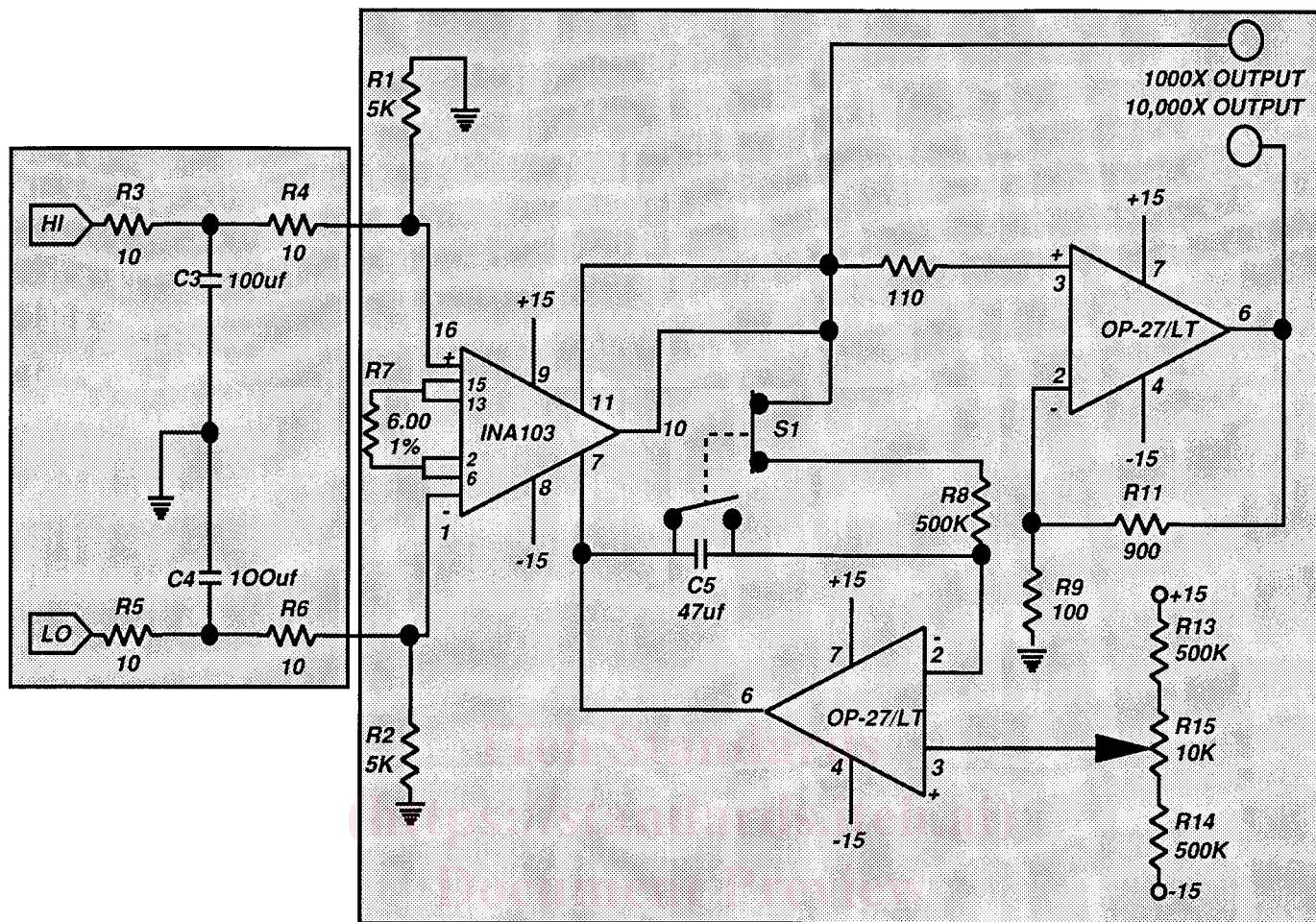

S1 for Auto Zero

FIG. 2 Recommended Low Noise Amplifier Schematic Diagram

## 8. Sampling

8.1 The number of measurements shall be subject to agreement by the parties to the test.

## 9. Calibration

9.1 The LNA and data-recorder should be calibrated to be within  $\pm 2\%$  of full scale.

## 10. Procedure

### 10.1 Single-Pulse Method:

10.1.1 Position the calorimeter at the location where the dose measurement is desired.

10.1.2 Connect all components of the calorimetric dosimeter system in accordance with the circuit shown in Fig. 1.

10.1.3 Set the LNA for a gain of 10 000 (1000), if using the thermistor circuit).

10.1.3 Set the LNA for a gain of 10 000 (or 1000, if using the thermistor circuit).

NOTE 5—A LNA is not always needed if the calorimeter is used at high dose positions. The signal is often quite large.

10.1.4 For the thermocouple measurements, adjust either the internal nulling circuit of the LNA or the external bucking circuit so that the meter deflection caused by the quiescent level of the calorimeter output is less than full scale. For thermistor measurements adjust the bridge for a null. Use the zero-adjust capability of the data recorder to position the recorder trace near the center of the recorder chart. For the thermocouple measurements, adjust either the internal nulling circuit of the LNA or the external bucking circuit so that the meter deflection caused by the quiescent level of the calorimeter output is less than full scale. For thermistor measurements adjust the bridge for a null. Use the zero-adjust capability of the data recorder to position the recorder trace near the center of the recorder chart. If using the oscilloscope, adjust the settings accordingly to make sure that the response is noticeable within the oscilloscope window. Refer to the oscilloscope manual to ensure that the proper resolution are set to capture the response signal.

NOTE 5—With 6—With either system, there will likely be a drift as the temperature of the calorimeter equilibrates. This drift is compensated for in data

reduction and may be neglected if the rate of change is much less than that caused by the radiation pulse.

10.1.5 ~~With the~~ If using a data recorder sweep speed set within the range from 0.5 to 2.0 cm/s, inclusive, trigger the recorder and pulse the ~~line~~ source.

10.1.6 If the transient deflection of the recorder is less than 10 % of full scale, set the recorder range to the next lower range and repeat 10.1.5.

NOTE 7—Care should be taken if multiple pulses are going to be administered, because of the temperature that the pulses emit, which will cause the calorimeter to rise. It should be stated up front that you are going to use a five pulse average as being representative of all shots. This test should be done two or three times during a shot day. If you want best accuracy, wait for the calorimeter to cool down between pulses and allow the calorimeter signal to use at least half the range.

10.1.7 Repeat 10.1.5 and 10.1.6 until a range is found for which the greater-than-10 % criterion is met, or until there are no more ranges to try.

10.1.7.1 When a range is found for which this greater-than-10 % criterion is met, annotate the data recorder output beside the recorded transient with the shot number, date, LNA gain, calorimeter identification, and description of irradiation geometry (including scatterer thickness and distance of the calorimeter from the scatterer) as shown in Fig. 3 and Fig. 4.

10.1.7.2 If no range is found for which a 10 % deflection is obtained which is easily distinguishable from noise, use the multiple-pulse method beginning with 10.2.2.

10.1.7.3 Otherwise, repeat 10.1.7.1 four more times.

10.1.7.4 If using an oscilloscope, set the necessary parameters to capture the response. Refer to the oscilloscope reference manual to set the parameters.

10.2 *Multiple-Pulse Method:*

10.2.1 Carry out 10.1.1 through 10.1.4.

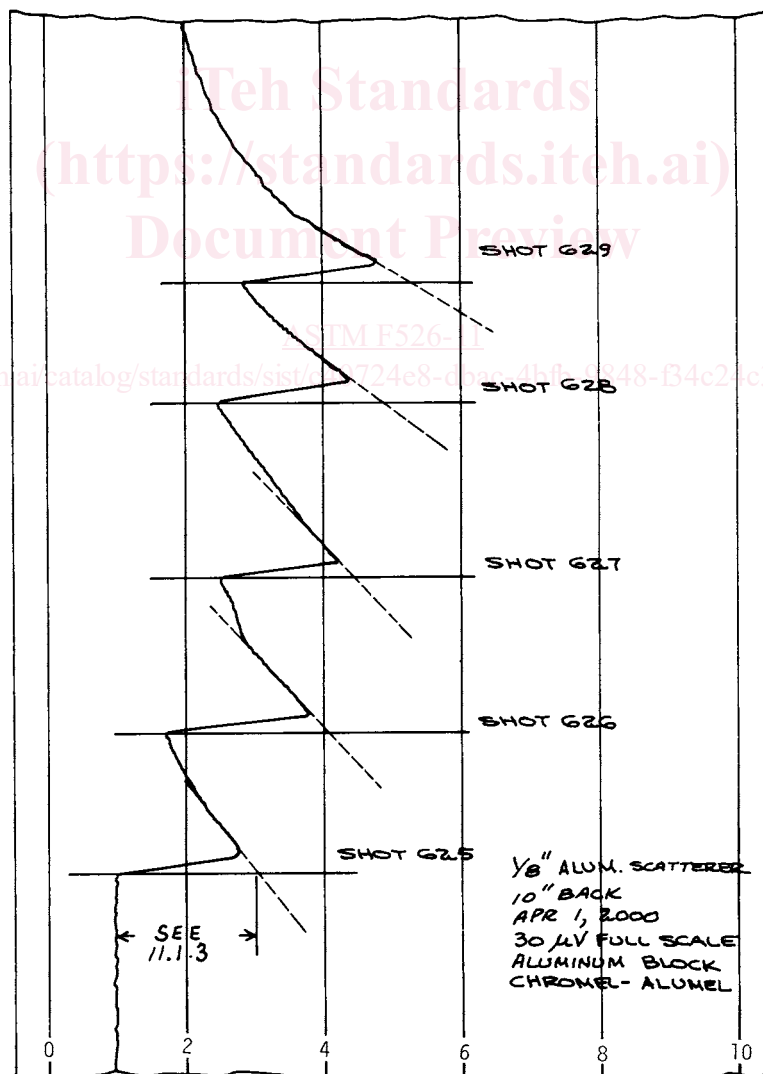
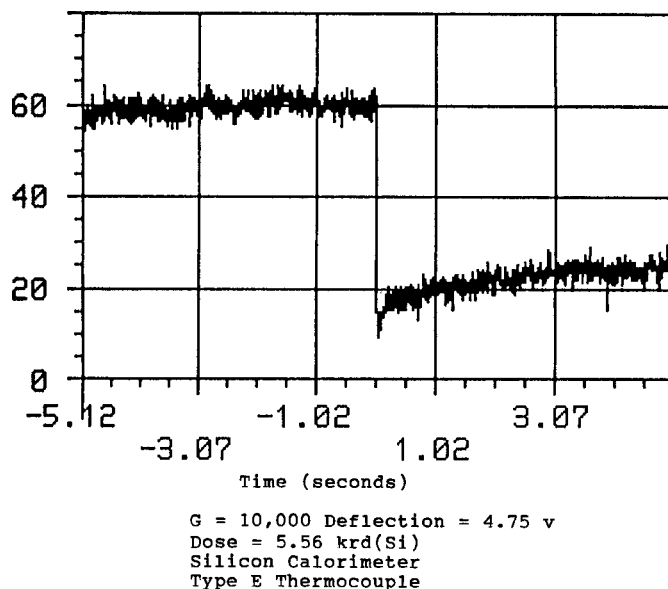

FIG. 3 Typical Chart Record of Calorimeter Dosimetry Using Single-Pulse Method



**FIG. 4 Typical Digital Oscilloscope Recording of the Calorimeter Response**

10.2.2 With If using the recorder chart speed set within the range from 0.5 to 2.0 cm/s, inclusive, pulse the Linac repeatedly within a time that is short compared to the thermal time constant of the calorimeter to give a recorder deflection greater than 10 % of full scale.

10.2.2.1 From the data, measure the voltage rise resulting from this series of pulses.

10.2.2.2 For the time interval beginning with the cessation of the radiation and equal in duration to the total time during which the radiation dose was accumulated, measure the thermocouple voltage drop.

10.2.2.3 Calculate the ratio of the voltage from 10.2.2.2 to that of 10.2.2.1.

10.2.2.4 If this ratio is less than 0.15, continue with 10.2.3 (the thermal time constant of the calorimeter is sufficiently greater than the radiation time for the dose to be determined accurately).

10.2.2.5 If this ratio is equal to or greater than 0.15, repeat 10.2.2 through 10.2.2.5 using a higher pulse repetition rate for a shorter radiation time period.

10.2.3 Annotate the data recorder output, as well as the number of pulses used (see Fig. 5, Fig. 6, and Fig. 7).

10.2.4 Repeat 10.2.2 and 10.2.3 four more times, omitting the time constant determination (10.2.2.1 through 10.2.2.5).

10.2.5 If using the oscilloscope, refer to the reference manual to set the oscilloscope, pulse the linac repeatedly within a time that is short compared to the thermal time constant of the calorimeter to ensure that the response is properly captured on the oscilloscope.

## 11. Calculation and Interpretation of Results

### 11.1 Single-Pulse Method:

11.1.1 On the recorder output, determine the perpendicular to the time axis at the start of each transient, as shown in Fig. 3.

11.1.2 Determine whether a period of time was required for the temperature to equilibrate after the pulse, as indicated by the presence of a spike (Fig. 5a) or a flat portion (Fig. 5b) of the data recorder trace at the end of the transient.

11.1.2.1 If no such feature is present, draw a line extrapolating the steepest part of the cooling curve following each radiation pulse back to intersect the perpendicular line (see 11.1.1). When using digital storage oscilloscopes, built in cursors usually can be used.

NOTE 6—These 8—These lines are dashed in Fig. 3.

11.1.2.2 If such a feature is present, draw a line extrapolating from the slope of the curve where a smooth cooling trend resumes. Do this for each pulse.

NOTE 7—These 9—These lines are dashed in Fig. 5.

11.1.3 Measure along each perpendicular line the length from the start of each transient to the intersection of the perpendicular line with the extrapolated line.

11.1.4 Convert these measurements to output voltage level.

11.1.5 For each pulse calculate and record the dose in Gy (calorimeter-block material) producing the transient, using for a thermocouple measurement, the relation:

$$\text{Dose} = 100 V_c / PG \quad (1)$$