**Road vehicles — Component test
methods for electrical disturbances
from narrowband radiated
electromagnetic energy —**

Part 9:

Portable transmitters

iTeh STANDARD PREVIEW
(standards.iteh.ai)

*Véhicules routiers — Méthodes d'essai d'un équipement soumis
à des perturbations électriques par rayonnement d'énergie
électromagnétique en bande étroite —*

ISO 11452-9:2021

Partie 9: Émetteurs portables

<https://standards.iteh.ai/catalog/standards/sist/140c1600-a8b0-4db4-8657-d7af3cfa5d8/iso-11452-9-2021>



iTeh STANDARD PREVIEW (standards.iteh.ai)

ISO 11452-9:2021

<https://standards.iteh.ai/catalog/standards/sist/14be166b-a8b0-4db4-8657-d7af3cffa5d8/iso-11452-9-2021>



COPYRIGHT PROTECTED DOCUMENT

© ISO 2021

All rights reserved. Unless otherwise specified, or required in the context of its implementation, no part of this publication may be reproduced or utilized otherwise in any form or by any means, electronic or mechanical, including photocopying, or posting on the internet or an intranet, without prior written permission. Permission can be requested from either ISO at the address below or ISO's member body in the country of the requester.

ISO copyright office
CP 401 • Ch. de Blandonnet 8
CH-1214 Vernier, Geneva
Phone: +41 22 749 01 11
Email: copyright@iso.org
Website: www.iso.org

Published in Switzerland

Contents

	Page
Foreword.....	iv
1 Scope.....	1
2 Normative references.....	1
3 Terms and definitions.....	1
4 Test conditions.....	1
5 Test location.....	2
6 Test instrumentation.....	2
6.1 General.....	2
6.2 Simulated portable transmitters.....	2
6.2.1 General.....	2
6.2.2 Dual directional coupler.....	3
6.2.3 Power monitoring.....	3
6.2.4 Low loss coaxial cable.....	4
6.2.5 Vector network analyser (VNA).....	4
6.2.6 Transmit antenna.....	4
6.2.7 Stimulation and monitoring of the DUT.....	5
7 Test set-up.....	5
7.1 Ground plane.....	5
7.2 LV power supply system.....	5
7.3 HV power supply system.....	6
7.4 Location of the DUT.....	6
7.5 Location of the test harness.....	7
7.6 Location of the load simulator.....	7
7.7 Location of the simulated portable transmitter equipment.....	7
8 Test procedure.....	17
8.1 General.....	17
8.2 Test plan.....	17
8.3 Test procedure.....	17
8.3.1 General.....	17
8.3.2 DUT test.....	18
8.3.3 Antenna positioning for coupling to the DUT/connectors.....	21
8.3.4 Antenna positioning for coupling to harness.....	26
8.4 Test report.....	36
Annex A (normative) Net power characterization procedure.....	37
Annex B (informative) Typical characteristics and use of portable transmitters.....	48
Annex C (informative) Characteristics of simulated portable transmitter antenna.....	51
Annex D (informative) Function performance status classification (FPSC).....	73
Annex E (informative) Remote/local grounding.....	74
Annex F (informative) Broadband noise source by AWG (arbitrary waveform generator).....	76

Foreword

ISO (the International Organization for Standardization) is a worldwide federation of national standards bodies (ISO member bodies). The work of preparing International Standards is normally carried out through ISO technical committees. Each member body interested in a subject for which a technical committee has been established has the right to be represented on that committee. International organizations, governmental and non-governmental, in liaison with ISO, also take part in the work. ISO collaborates closely with the International Electrotechnical Commission (IEC) on all matters of electrotechnical standardization.

The procedures used to develop this document and those intended for its further maintenance are described in the ISO/IEC Directives, Part 1. In particular, the different approval criteria needed for the different types of ISO documents should be noted. This document was drafted in accordance with the editorial rules of the ISO/IEC Directives, Part 2 (see www.iso.org/directives).

Attention is drawn to the possibility that some of the elements of this document may be the subject of patent rights. ISO shall not be held responsible for identifying any or all such patent rights. Details of any patent rights identified during the development of the document will be in the Introduction and/or on the ISO list of patent declarations received (see www.iso.org/patents).

Any trade name used in this document is information given for the convenience of users and does not constitute an endorsement.

For an explanation of the voluntary nature of standards, the meaning of ISO specific terms and expressions related to conformity assessment, as well as information about ISO's adherence to the World Trade Organization (WTO) principles in the Technical Barriers to Trade (TBT), see www.iso.org/iso/foreword.html.

This document was prepared by Technical Committee ISO/TC 22, *Road vehicles*, Subcommittee SC 32, *Electrical and electronic components and general system aspects*.

This second edition cancels and replaces the first edition (ISO 11452-9:2012), which has been technically revised.

The main changes are as follows:

- change of the frequency range from 26 MHz – 5,85 GHz to 142 MHz – 6 GHz;
- suppression of test methodology with commercial transmitters;
- use of modulation from ISO 11452-1;
- modifications of ground plane dimensions;
- introduction of additional artificial networks (HV-AN, AMN, AAN) for DUT powered by a shielded power system;
- addition of test set-up descriptions and figures for HV power supply system;
- addition of wording for DUT, connector and harness testing;
- addition of new [Annex A](#) with description of test methodology for net power characterization procedure;
- addition in [Annex C](#) of microwave broadband dipole antenna and HF broadband sleeve antenna;
- addition of [Annex F](#) on broadband noise source with arbitrary waveform generator.

A list of all parts in the ISO 11452 series can be found on the ISO website.

Any feedback or questions on this document should be directed to the user's national standards body. A complete listing of these bodies can be found at www.iso.org/members.html.

Road vehicles — Component test methods for electrical disturbances from narrowband radiated electromagnetic energy —

Part 9: Portable transmitters

1 Scope

This document specifies test methods and procedures for testing electromagnetic immunity of electronic components for passenger cars and commercial vehicles to portable transmitters in close proximity, regardless of the propulsion system (e.g. spark-ignition engine, diesel engine, electric motor). The device under test (DUT), together with the wiring harness (prototype or standard test harness), is subjected to an electromagnetic disturbance generated by portable transmitters inside an absorber-lined shielded enclosure, with peripheral devices either inside or outside the enclosure. The electromagnetic disturbances considered are limited to continuous narrowband electromagnetic fields.

2 Normative references

The following documents are referred to in the text in such a way that some or all of their content constitutes requirements of this document. For dated references, only the edition cited applies. For undated references, the latest edition of the referenced document (including any amendments) applies.

ISO 11452-1, *Road vehicles — Component test methods for electrical disturbances from narrowband radiated electromagnetic energy — Part 1: General principles and terminology*

Guidelines for limiting exposure to time-varying electric, magnetic, and electromagnetic fields (up to 300 GHz). International Commission on Non-Ionizing Radiation Protection (ICNIRP)

3 Terms and definitions

For the purposes of this document, the terms and definitions given in ISO 11452-1 and the following apply.

ISO and IEC maintain terminology databases for use in standardization at the following addresses:

- ISO Online browsing platform: available at <https://www.iso.org/obp>
- IEC Electropedia: available at <https://www.electropedia.org/>

3.1

reference position

geometrical centre of the radiation pattern of the antenna, which is determined by the manufacturer based on near field measurement

4 Test conditions

The applicable frequency range of the test method is 142 MHz to 6 GHz.

The user of this document shall specify the test severity level or levels over the frequency bands. The test severity level shall take into account:

- typical portable transmitter characteristics (frequency bands, power level and modulation), and
- the characteristics of the antenna(s) used for this test.

The user shall specify the test severity level(s) over the frequency range. Suggested test levels are included in [Annex D](#).

Standard test conditions are given in ISO 11452-1 for the following:

- test temperature;
- supply voltage;
- dwell time;
- test signal quality;
- frequency steps;
- modulation.

NOTE Alternate modulations, if required, can be found in [Annex B](#). Users of this document are advised that [Annex B](#) is for information only and cannot be considered as an exhaustive description of various portable transmitters available in all countries.

ITeH STANDARD PREVIEW
(standards.iteh.ai)

5 Test location

The test shall be performed in an absorber lined shielded enclosure (ALSE).

6 Test instrumentation

<https://standards.iteh.ai/catalog/standards/sist/14be166b-a8b0-4db4-8657-d7af3cffa5d8/iso-11452-9-2021>

6.1 General

The field-generating device shall be simulated portable transmitters, with a broadband amplifier connected to a transmit antenna.

Test personnel shall be protected in accordance with ICNIRP Guidelines.

NOTE National or other regulations can apply.

6.2 Simulated portable transmitters

6.2.1 General

The following equipment is used:

- ground plane;
- radio frequency (RF) generator with internal or external modulation capability;
- power amplifier;
- power measuring instrumentation to measure the forward and reverse power;
- dual directional coupler;
- low loss coaxial cables;

- vector network analyser (VNA);
- transmit antenna;
- artificial networks (AN), and/or high voltage artificial networks (HV-AN), and/or artificial mains networks (AMN), and/or asymmetric artificial networks (AAN).

Figure 1 illustrates the basic setup for the RF generation equipment. Testing is based on a required net power (P_{NA}) applied to the test antenna. The net power level is derived from the forward power (P_{FM}) measured at the directional coupler, which is remotely connected to the transmit antenna via low loss coaxial cable. Requirements on directional coupler, cable and power sensors are listed in 6.2.2 to 6.2.4. The procedures delineated in Annex A shall be used determine the required forward power to achieve the net power levels listed in Annex A or within the test plan. Although not required, it is highly recommended to use a single directional coupler to cover the entire frequency band.

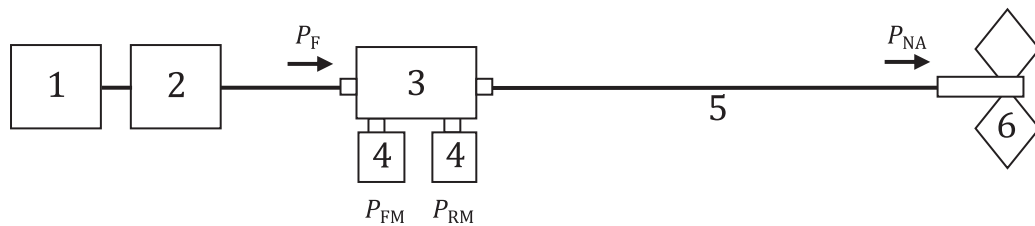

Key

1	RF signal generator	P_{FM}	measured forward power at the directional coupler
2	RF amplifier	P_{RM}	measured reverse power at the directional coupler
3	dual directional coupler	P_{NA}	net power delivered to antenna
4	power sensor or measurement receiver		
5	low loss coaxial cable with transmission loss		
6	transmit antenna		

<https://standards.iteh.ai/catalog/standards/sist/14be166b-a8b0-4db4-8657-d7af3cfa5d8/iso-11452-9-2021>
 ISO 11452-9:2021

Figure 1 — RF generation equipment setup

6.2.2 Dual directional coupler

The coupler shall exhibit the following characteristics:

- coupling factor: >20 dB (40 dB recommended),
- mainline port VSWR: <1,3,
- coupling port VSWR: <1,5,
- mainline transmission loss: <0,5 dB,
- directivity: >18 dB.

Selection of coupling factor (20 – 40 dB) shall be compatible with the sensitivity of the measurement equipment used to measure forward and reflected power (see 6.2.3 for details).

6.2.3 Power monitoring

Either power sensors or a spectrum analyser (or measurement receiver) shall be used for measurement of the forward and reflected power at the dual directional coupler.

When power sensors are used to measure forward and reflected power:

- CW or AM signal shall be measured either with an average or peak power sensor (peak conservation may be applied for AM per ISO 11452-1);

- pulsed power modulation shall be measured with a peak envelope power sensor;
- power sensors should be connected directly to the coupler ports;
- power sensors shall exhibit a VSWR <1,2 and a measurement accuracy <0,5 dB.

When a spectrum analyser (or measurement receiver) is used to measure forward and reflected power, it shall exhibit the same VSWR and measurement accuracy as required for power sensors.

When the sensors or a spectrum analyser (or measurement receiver) are connected to the coupler via coaxial cables, the cable's transmission loss shall be taken into account during characterization. See [Annex A](#) for details.

6.2.4 Low loss coaxial cable

The 50 Ω coaxial cable assembly (including all adaptors, switches, etc.) connecting the dual directional coupler to the transmit antenna shall exhibit a VSWR <1,1 and transmission loss <4 dB. Verification shall be performed in accordance with [Annex A](#).

6.2.5 Vector network analyser (VNA)

The VNA shall exhibit the following characteristics:

- frequency range: 142 MHz – 6 GHz,
- frequency step: specified by the manufacturer (logarithmic step recommended),
- dynamic range: >60 dB (IF bandwidth <3 kHz),
- return loss: >32 dB,
- transmission loss accuracy: <0,1 dB,
- power level: 0 dBm (recommended value),
- minimum averaging factor (optional),
- minimum number of points: 401 (with logarithmic sweep),
- IF bandwidth: selected to meet return and transmission loss requirements (typically 1 kHz),
- VNA calibration kit to facilitate TOSM (through, open, short, matched) measurements:
 - termination through: return loss >35 dB,
 - termination short/open: deviation in nominal phase <2°,
 - termination match: return loss >40 dB,
 - it is recommended to use the same connector type to match that of the interconnecting cable assembly and transmit antenna (avoid using adaptors).

6.2.6 Transmit antenna

The transmit antenna shall be a passive antenna. For accurate exposure during testing, the following commercially available antennas are listed in [Table 1](#).

Details associated with each antenna are found in [Annex C](#). Only one type of antenna is required for the frequency range being tested.

Testing requires near field excitation of the DUT and its attached harness. To facilitate this, the transmit antennas listed in [Table 1](#) have specific reference positions where the magnitude of the electric and magnetic fields are at a maximum, dependent on the test frequency. To ensure testing is accurately

executed, the reference positions shall be clearly defined by the antenna manufacturer for each transmitting antenna (see [Annex C](#) for guidance).

Table 1 — Transmit antenna types

Antenna description	Frequency coverage
Folded dipole antennas	142 MHz – 246 MHz
Sleeve antennas	380 MHz – 460 MHz ^a
Broadband dipole antenna	360 MHz – 2 700 MHz
Broadband sleeve antenna	700 MHz – 3 200 MHz
Microwave broadband dipole antenna	2 000 MHz – 6 000 MHz
HF broadband sleeve antenna	2 400 MHz – 6 000 MHz
^a Requires antenna tuning for selected test frequencies (see Annex C).	

6.2.7 Stimulation and monitoring of the DUT

The DUT shall be operated in accordance with the test plan by actuators which have a minimum effect on the electromagnetic characteristics, for example, plastic blocks on the pushbuttons, pneumatic actuators with plastic tubes.

Connections to equipment monitoring electromagnetic interference reactions of the DUT may be accomplished by using fibre-optics or high-resistance leads. Other types of leads may be used but require extreme care to minimize interactions. The orientation, length and location of such leads shall be carefully documented to ensure repeatability of test results.

CAUTION — Any electrical connection of monitoring equipment to the DUT could cause malfunctions of the DUT. Extreme care shall be taken to avoid such an effect.

[ISO 11452-9:2021](https://standards.iteh.ai/catalog/standards/sist/14be166b-a8b0-4db4-8657-d7af3cffa5d8/iso-11452-9-2021)

<https://standards.iteh.ai/catalog/standards/sist/14be166b-a8b0-4db4-8657-d7af3cffa5d8/iso-11452-9-2021>

7 Test set-up

7.1 Ground plane

The ground plane shall be made of 0,5 mm thick (minimum) copper, brass or galvanized steel.

The minimum width of the ground plane shall be 1 000 mm, or the width of the entire underneath of the test setup [DUT and associated equipment (e.g. harness including supply lines, load simulator located on the test bench and AN(s)), excluding battery and/or power supply] plus 200 mm, whichever is the larger.

The minimum length of the ground plane shall be 2 000 mm, or the length of the entire underneath of the test setup [DUT and associated equipment (e.g. harness including supply lines, load simulator located on the test bench and AN(s)), excluding battery and/or power supply] plus 200 mm, whichever is the larger.

The height of the ground plane (test bench) shall be (900 ± 100) mm above the floor.

The ground plane shall be bonded to the shielded enclosure such that the DC resistance shall not exceed 2,5 mΩ. The distance from the edge of the ground strap to the edge of the next strap shall not be greater than 300 mm. The maximum length to width ratio for the ground straps shall be 7:1.

7.2 LV power supply system

[Figures 2](#) and [3](#) show the test bench setup when using only a LV power supply system.

Each DUT power supply lead shall be connected to the power supply through an artificial network (AN).

Power shall be applied to the DUT via a 5 $\mu\text{H}/50\ \Omega$ AN. Whether two ANs or only one is required depends on the intended DUT installation in the vehicle:

- for remotely grounded DUTs (vehicle power return line longer than 200 mm), two ANs are required, one AN for the positive supply line and the other AN for the power return line (see [Annex E](#));
- for locally grounded DUTs (vehicle power return line 200 mm or shorter), only one AN is required, for the positive supply (see [Annex E](#)).

The AN(s) shall be mounted directly on the ground plane. AN cases shall be bonded to the ground plane.

The power supply return shall be connected to the ground plane, between the power supply and the AN(s).

The measuring port of each AN shall be terminated with a 50 Ω load.

7.3 HV power supply system

[Figures 4](#) to [7](#) show the test bench setup when using an HV power supply system.

Each DUT power supply lead shall be connected to the power supply through an HV AN (for DUT with DC HV supply) and/or AMN (for DUT with AC supply).

- DC HV supply shall be applied to the DUT via a 5 $\mu\text{H}/50\ \Omega$ HV AN (see ISO 11452-1:2015, Annex B for the schematic).
- AC supply shall be applied to the DUT via a 50 $\mu\text{H}/50\ \Omega$ AMN (see ISO 11452-1:2015, Annex B for the schematic).

The HV AN(s) shall be mounted directly on the ground plane. The case or cases of the HV AN(s) shall be bonded to the ground plane.

The measuring port of each HV AN(s) shall be terminated with a 50 Ω load.

The vehicle HV battery should be used; otherwise, the external HV power supply shall be connected via feed-through-filtering.

Shielded supply lines for the positive HV DC terminal line (HV+), the negative HV DC terminal line (HV-) and three phase HV AC lines may be separate coaxial cables or in a common shield depending on the connector system used.

The shielded harnesses used for this test shall be representative of the vehicle application in terms of cable construction and connector termination as defined in the test plan.

For the charger, the AMN(s) shall be mounted on the test facility floor ground plane. The case or cases of the AMN(s) shall be bonded to the test facility floor ground plane. The charger PE (protective earth) line shall be bounded to the test set-up ground plane and to the AMN(s) PE connection.

The measuring port of each HV AN(s) / AMN(s) shall be terminated with a 50 Ω load.

7.4 Location of the DUT

For LV power supply system, unless otherwise specified, the DUT shall be placed on non-conductive material of low relative permittivity (dielectric constant) ($\epsilon_r \leq 1,4$) at least 50 mm above the ground plane. The height shall be selected to assure that no portion of the transmit antenna is any closer than 50 mm to the ground plane. The DUT height selected shall be documented in the test plan.

The case of the DUT shall not be grounded to the ground plane unless it is intended to simulate the actual vehicle configuration.

For HV power supply system, unless otherwise specified, the DUT shall be placed directly on the ground plane with the DUT case bonded to the ground plane either directly or via defined impedance.

The DUT shall be located at least 100 mm from the edge of the ground plane.

7.5 Location of the test harness

For LV power supply system, the total length of the test harness between the DUT and the load simulator (or the RF boundary) shall be $(1\,700 +300/0)$ mm. The part of the test harness parallel to the front edge of the ground plane shall be at least 1 400 mm.

For HV power supply system, unless otherwise specified in the test plan (e.g. use of original vehicle harnesses), the total length of harnesses shall be as follows:

- $(1\,700 +300/0)$ mm for the LV lines and the length of the LV test harness parallel to the front of the ground plane shall be at least 1 400 mm;
- $(1\,700 +300/0)$ mm for the HV lines and the length of the HV test harness parallel to the front of the ground plane shall be at least 1 400 mm;
- $(1\,700 +300/0)$ mm for the AC lines and the length of the AC test harness parallel to the front of the ground plane shall be at least 1 400 mm and
- less than 1 000 mm for the three phase lines between DUT and electric motor(s).

If the HV test harness is over 2 000 mm, the HV test harness length should be defined in the test plan and described in the test report.

The wiring type (e.g. single wires, twisted wire pairs) is defined by the actual system application and requirement.

The test harness shall be placed on non-conductive material of low relative permittivity (dielectric constant) ($\epsilon_r \leq 1,4$) at (50 ± 5) mm above the ground plane.

The LV test harness shall be located at least 200 mm from the edge of the ground plane. The long segment of the shielded HV power harness, if present, shall be located at $100 +100/0$ mm from the LV harness.

For an inverter/charger device, the setup in [Figures 6](#) and [7](#) are examples of further HV and LV load simulators and supplies attached to the DUT, e.g. for testing an on-board charger and its communication links. The distance between the AC power lines and the closest harness (LV or HV) shall be $100 +100/0$ mm.

7.6 Location of the load simulator

Unless otherwise specified in the test plan, the load simulator (designed to simulate typical loading as in the vehicle) shall be placed directly on the ground plane. If the load simulator has a metallic case, this case shall be bonded to the ground plane.

Alternatively, the load simulator may be located adjacent to the ground plane (with the case of the load simulator bonded to the ground plane) or outside of the test chamber, provided the test harness from the DUT passes through an RF boundary bonded to the ground plane. The layout of the test harness that is connected to the load simulator shall be defined in the test plan and recorded in the test report.

When the load simulator is located on the ground plane, the DC power supply lines of the load simulator shall be connected through the AN(s).

7.7 Location of the simulated portable transmitter equipment.

The interconnection between the directional coupler and the transmit antenna is a critical factor in minimizing error in the net power delivered to the antenna.

There are two alternative configurations.

- Configuration 1 locates the RF signal generation equipment, dual directional coupler and power monitoring equipment outside of the ALSE. In this configuration, the coupler and coaxial cable are connected via a single bulkhead connector.
- Configuration 2 locates the RF signal generation equipment, dual direction coupler and power monitoring equipment inside the ALSE. In this configuration, the coaxial cable connects directly to coupler. Use of this configuration requires powering of the equipment internal to the test chamber. Also, sufficient separation between the equipment and the transmit antenna should be considered to avoid possible functional issues due to RF fields produced.

In both cases, a single low loss coaxial cable serves as the interconnection between the dual directional coupler and the antenna. Use of in-line connectors and/or adaptors should be avoided wherever possible to reduce error due to the accumulated impedance mismatch introduced by use of these devices. The impedance mismatch directly affects the net power.

Examples of test set-ups are shown in [Figures 2](#) and [3](#) (for LV power supply system in configurations 1 and 2) and in [Figures 4](#) to [7](#) (for HV power supply system in configurations 1 and 2).

iTeh STANDARD PREVIEW (standards.iteh.ai)

[ISO 11452-9:2021](#)

<https://standards.iteh.ai/catalog/standards/sist/14be166b-a8b0-4db4-8657-d7af3cffa5d8/iso-11452-9-2021>

Dimensions in millimetres

Upper view

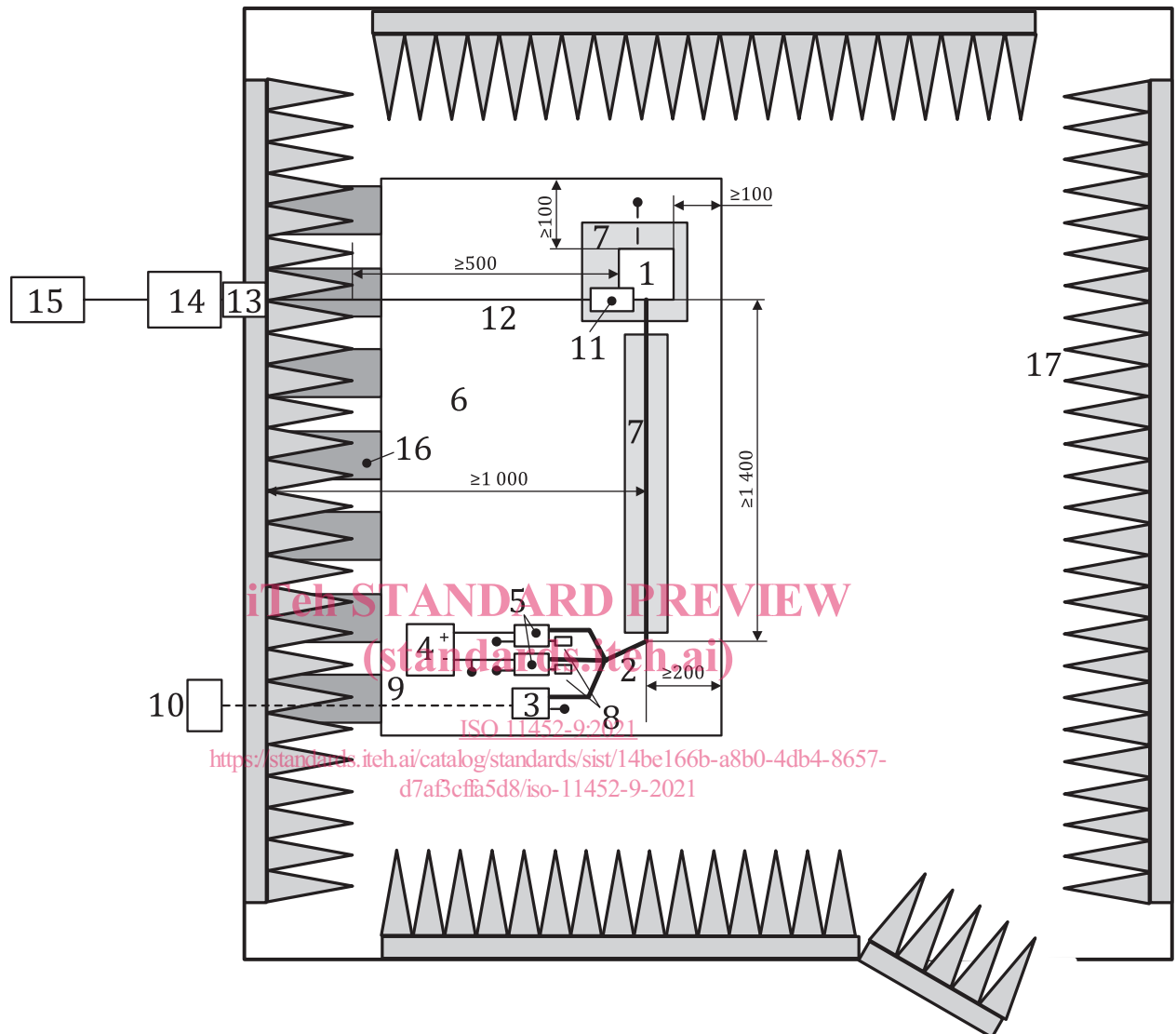

Key

- | | |
|---|--|
| 1 DUT (grounded locally if required in test plan) | 10 stimulation and monitoring system |
| 2 LV test harness | 11 simulated portable transmitter antenna |
| 3 load simulator (placement and ground connection according to 6) | 12 high-quality double-shielded coaxial cable (50 Ω) |
| 4 power supply (location optional) | 13 bulkhead connector |
| 5 artificial network (AN) | 14 dual directional coupler |
| 6 ground plane (bonded to shielded enclosure) | 15 RF generation and power monitoring equipment |
| 7 low relative permittivity support ($\epsilon_r \leq 1,4$) | 16 ground straps |
| 8 50 Ω load | 17 RF absorber material |
| 9 optical fibre | |

Figure 2 — Example of LV power supply system test setup (configuration 1)

Upper view

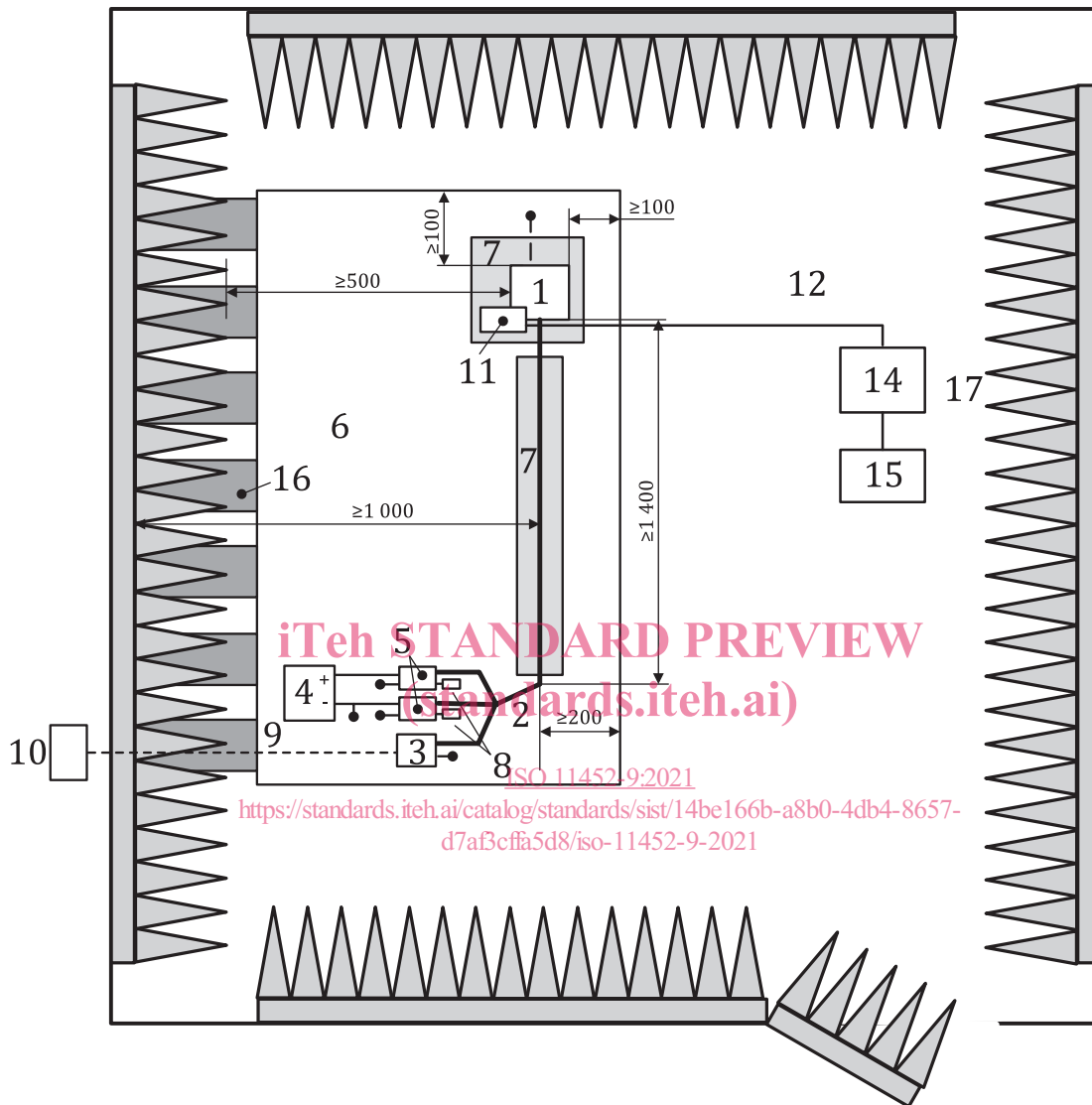

Key

- | | |
|---|--|
| 1 DUT (grounded locally if required in test plan) | 9 optical fibre |
| 2 LV test harness | 10 stimulation and monitoring system |
| 3 load simulator (placement and ground connection according to 7.6) | 11 simulated portable transmitter antenna |
| 4 power supply (location optional) | 12 high-quality double-shielded coaxial cable (50 Ω) |
| 5 artificial network (AN) | 14 dual directional coupler |
| 6 ground plane (bonded to shielded enclosure) | 15 RF generation and power monitoring equipment |
| 7 low relative permittivity support ($\epsilon_r \leq 1,4$) | 16 ground straps |
| 8 50 Ω load | 17 RF absorber material |

Figure 3 — Example of LV power supply system test setup (configuration 2)

Upper view

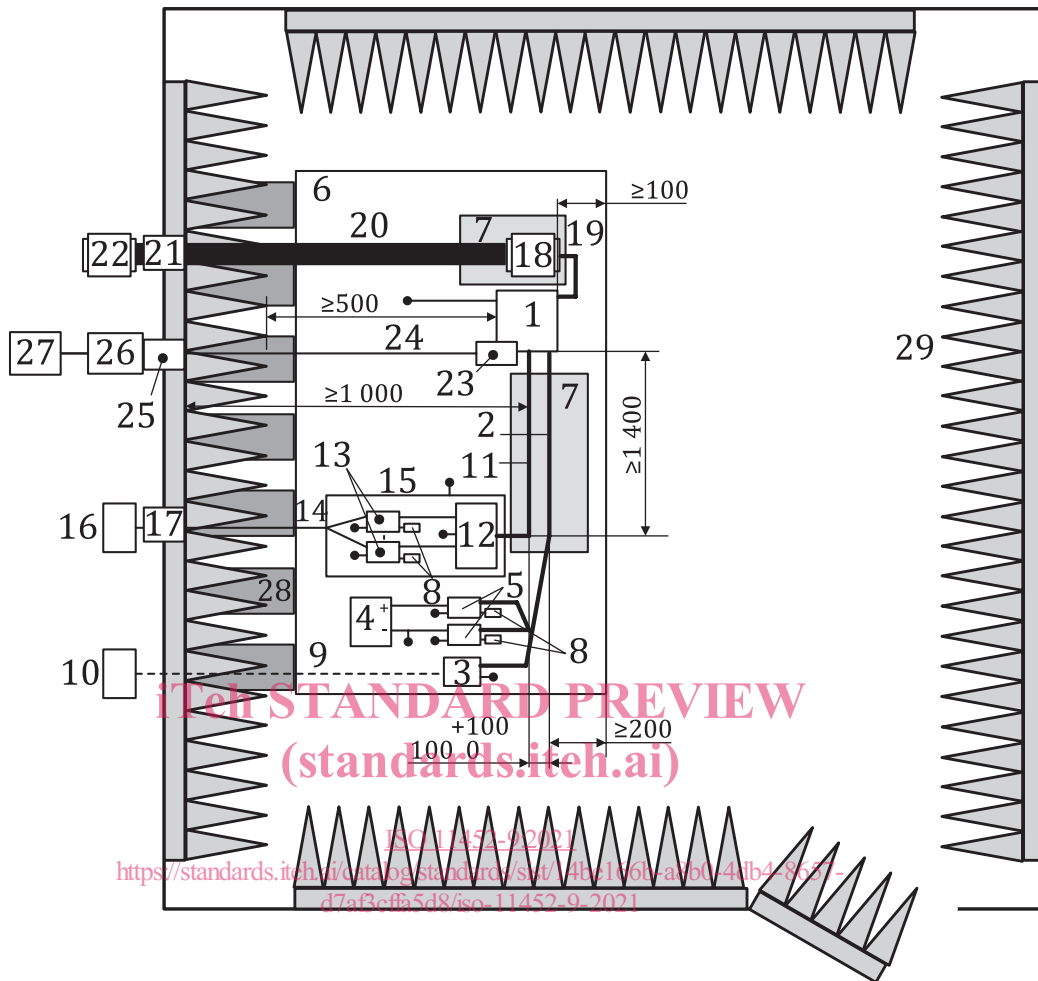

Key

1	DUT (grounded locally if required in test plan)	11	HV lines (HV+, HV-)	21	filtered mechanical bearing
2	LV test harness	12	impedance matching network (optional) (see ISO 11452-1)	22	brake or propulsion motor
3	load simulator (placement and ground connection according to 7.6)	13	HV AN	23	simulated portable transmitter antenna
4	power supply (location optional)	14	HV supply lines	24	high-quality double-shielded coaxial cable (50 Ω)
5	artificial network (AN)	15	additional shielded box	25	bulkhead connector
6	ground plane (bonded to shielded enclosure)	16	HV power supply (shielded if placed inside ALSE)	26	dual directional coupler
7	low relative permittivity support ($\epsilon_r \leq 1,4$)	17	power line filter	27	RF generation and power monitoring equipment
8	50 Ω load	18	electric motor	28	ground straps
9	optical fibre	19	three phase motor supply lines	29	RF absorber material