



Designation: D5133 – 05(Reapproved 2011)

# Standard Test Method for Low Temperature, Low Shear Rate, Viscosity/Temperature Dependence of Lubricating Oils Using a Temperature- Scanning Technique<sup>1</sup>

This standard is issued under the fixed designation D5133; the number immediately following the designation indicates the year of original adoption or, in the case of revision, the year of last revision. A number in parentheses indicates the year of last reapproval. A superscript epsilon ( $\epsilon$ ) indicates an editorial change since the last revision or reapproval.

## 1. Scope

1.1 This test method covers the measurement of the apparent viscosity of engine oil at low temperatures.

1.2 A shear rate of approximately  $0.2 \text{ s}^{-1}$  is produced at shear stresses below 100 Pa. Apparent viscosity is measured continuously as the sample is cooled at a rate of  $1^\circ\text{C}/\text{h}$  over the range  $-5$  to  $-40^\circ\text{C}$ , or to the temperature at which the viscosity exceeds  $40\,000 \text{ mPa}\cdot\text{s}$  (cP).

1.3 The measurements resulting from this test method are viscosity, the maximum rate of viscosity increase (Gelation Index), and the temperature at which the Gelation Index occurs.

1.4 Applicability to petroleum products other than engine oils has not been determined in preparing this test method.

1.5 The values stated in SI units are to be regarded as the standard. The values given in parentheses are for information only.

1.6 *This standard does not purport to address all of the safety concerns, if any, associated with its use. It is the responsibility of the user of this standard to establish appropriate safety and health practices and determine the applicability of regulatory limitations prior to use.*

## 2. Referenced Documents

2.1 *ASTM Standards:*<sup>2</sup>

[D341 Practice for Viscosity-Temperature Charts for Liquid Petroleum Products](#)

[D3829 Test Method for Predicting the Borderline Pumping Temperature of Engine Oil](#)

<sup>1</sup> This test method is under the jurisdiction of ASTM Committee D02 on Petroleum Products and Lubricants and is the direct responsibility of Subcommittee D02.07 on Flow Properties.

Current edition approved Jan. 1, 2011. Published February 2011. Originally approved in 1990. Last previous edition approved in 2005 as D5133 – 05. DOI: 10.1520/D5133-05R11.

<sup>2</sup> For referenced ASTM standards, visit the ASTM website, www.astm.org, or contact ASTM Customer Service at service@astm.org. For *Annual Book of ASTM Standards* volume information, refer to the standard's Document Summary page on the ASTM website.

[D4684 Test Method for Determination of Yield Stress and Apparent Viscosity of Engine Oils at Low Temperature](#)

## 3. Terminology

3.1 *Definitions:*

3.1.1 *apparent viscosity, n*—the viscosity obtained by use of this test method.

3.1.1.1 *Discussion*—See 3.1.6 for definition of viscosity and units.

3.1.2 *Newtonian oil, n*—an oil that, at a given temperature, exhibits a constant viscosity at all shear rates or shear stresses.

3.1.3 *non-Newtonian oil, n*—an oil that, at a given temperature, exhibits a viscosity that varies with shear stress or shear rate.

3.1.4 *shear rate, n*—velocity gradient perpendicular to the direction of flow.

3.1.4.1 *Discussion*—The SI unit for shear rate is the reciprocal second (1/s; also  $\text{s}^{-1}$ ).

3.1.5 *shear stress, n*—force per unit area in the direction of flow.

3.1.5.1 *Discussion*—The SI unit for shear stress is the Pascal (Pa).

3.1.6 *viscosity, n*—that property of a fluid which resists flow.

3.1.6.1 *Discussion*—Viscosity is defined as the ratio of the applied shear stress (force causing flow) and the shear rate (resultant velocity of flow per unit distance from a stationary surface wet by the fluid). Mathematically expressed:

$$\text{viscosity} = \text{shear stress/shear rate or, symbolically, } \eta = \tau/G \quad (1)$$

in which the symbols in the second portion of Eq 1 are defined by the terms in the first portion of the equation. The SI unit for viscosity used herein is milliPascal seconds (mPa·s).

3.2 *Definitions of Terms Specific to This Standard:*<sup>3</sup>

<sup>3</sup> The sole source of supply of the equipment and materials known to the committee at this time is Tannas Co., 4800 James Savage Rd., Midland, MI 48642. If you are aware of alternative suppliers, please provide this information to ASTM International Headquarters. Your comments will receive careful consideration at a meeting of the responsible technical committee,<sup>1</sup> which you may attend.

3.2.1 *air-binding oils*—those engine oils whose borderline pumping temperatures are determined by a combination of gelation and viscous flow.

3.2.2 *borderline pumping temperature, n*—that temperature at which an engine oil may have such poor flow characteristics that the engine oil pump may not be capable of supplying sufficient lubricant to the engine.

3.2.3 *calibration oil, n*—Newtonian oils developed and used to calibrate the viscometer drive module over the viscosity range required for this test method.

3.2.3.1 *Discussion*—these calibration oils are specially blended to give sufficient sensitivity and range for the special viscometer head used.

3.2.4 *computer-programmed automated analysis, n*—use of modern techniques for acquiring analog data, converting these to digital values and using this information to automatically record and analyze torque output from the viscometer drive module and to render this information into tabular data and plotted relationships.

3.2.4.1 *analog-to-digital (A-D) converter, n*—a device for converting continuously produced electrical signals into discrete numerical values capable of being analyzed by computer technology.

3.2.5 *critical pumpability temperature, n*—the temperature in the viscometer bath at which an oil reaches a chosen critical pumpability viscosity (see 3.2.6).

3.2.6 *critical pumpability viscosity, n*—that apparent viscosity believed to cause pumpability problems in an engine. This apparent viscosity is chosen to test an oil for its critical pumpability temperature.

3.2.7 *flow-limited oils, n*—those oils whose borderline pumping temperatures are determined by viscous flow.

3.2.8 *gelation, n*—a rheological condition of an oil characterized by a marked increase in the flow resistance over and above the normal exponential increase of viscosity with decreasing temperature, particularly at lower shear stresses and temperatures.

3.2.8.1 *Discussion*—Gelation has been attributed to a process of nucleation and crystallization of components of the engine oil and the formation of a structure.<sup>4</sup>

3.2.9 *Gelation Index, n*—the maximum value of the incremental ratio

$$-1[(\log \log \eta_1) - (\log \log \eta_2)] / (\log T_1 - \log T_2) \quad (2)$$

(in which  $\eta$  is dynamic viscosity and  $T$  is in degrees Kelvin) over the temperature range scanned when the incremental decrease in temperature is 1 K.

3.2.9.1 *Discussion*—The technique of deriving Gelation Index was first developed and practiced<sup>5</sup> collecting information from a strip-chart recording and applying the empirical MacCoull-Walther-Wright equation (Test Method D341). For further information, see Appendix X1.

<sup>4</sup> *Symposium on Low Temperature Lubricant Rheology Measurement and Relevance to Engine Operation, ASTM STP 1143*, Rhodes, R. B., ed., ASTM, 1992.

<sup>5</sup> Selby, T.W., "The Use of the Scanning Brookfield Technique to Study the Critical Degree of Gelation of Lubricants at Low Temperatures", SAE Paper 910746, Society of Automotive Engineers, 1991.

3.2.10 *Gelation Index reference oils, n*—non-Newtonian oils chosen to give certain levels of Gelation Index as a check on instrument performance<sup>3</sup>.

3.2.11 *Gelation Index temperature, n*—the temperature ( $t_2$  in Eq 2) in degrees Celsius at which the Gelation Index occurs.

3.2.12 *pre-treatment sample heating bath, n*—a water or air bath to heat the samples for 1.5 to 2.0 h at  $90 \pm 2^\circ\text{C}$  before testing.

3.2.13 *programmable liquid cold bath, n*—a liquid bath having a temperature controller capable of being programmed to run the calibration and the analysis portions of the test method.

3.2.14 *temperature controller, n*—a programmable device which, when properly programmed, ramps the temperature upward or downward at a chosen rate or series of steps while simultaneously controlling temperature excursions.

3.2.14.1 *calibration program, n*—a program to run the required series of temperatures at which the torque values necessary to calibrate the viscometer drive module are collected and analyzed.

3.2.14.2 *test program, n*—a program to run the test oil analysis at  $1^\circ\text{C}/\text{h}$  temperature decrease.

3.2.14.3 *hold program, n*—a program to reach and hold the programmable liquid cold bath at  $-5^\circ\text{C}$ .

3.2.15 *test cell, n*—the combination of the rotor and stator. Critical elements of the test cell are sketched in Fig. 1.

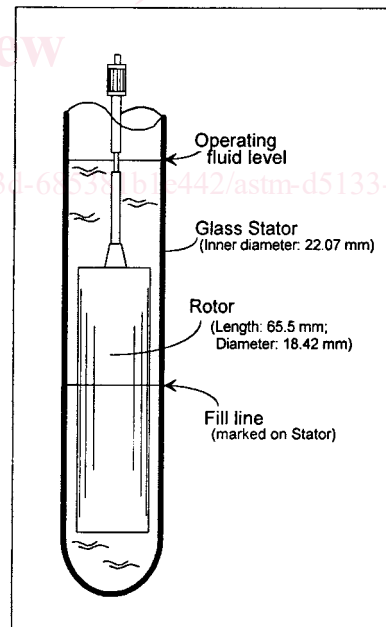

FIG. 1 Test Cell

3.2.15.1 *rotor, n*—a titanium rotor sized to give a compromise of sensitivity and range to the determination of viscosity and gelation using this test method.

(1) *stator, n*—a precision-bore borosilicate glass tube, to which a measured amount of oil is added for the test and within which the specially-made rotor turns.

(2) *stator collar, n*—a clamp for the stator which also positions it on the test cell alignment device.

3.2.16 *test cell alignment device*<sup>6</sup>, *n*—a special device used to support the viscometer drive module while maintaining the stator and the rotor coaxial and vertical in regard to the viscometer driveshaft. Later designs permit dry gas into the cell to prevent moisture and frost buildup.

3.2.17 *test oil, n*—any oil for which apparent viscosity is to be determined using the procedure described by this test method.

3.2.18 *viscometer drive module, n*—the rotor drive and torque-sensing component of a rotational viscometer.

3.2.19 *viscometer module support, n*—a part of the test cell alignment device supporting the viscometer drive module.

#### 4. Summary of Test Method

4.1 After pre-heating approximately 20 mL of the test oil in a glass stator at 90°C for 1.5 to 2.0 h., the test cell containing the test oil is attached to a suitable viscometer drive module and the test cell immersed in a liquid cold bath and cooled at 1°C/h over the temperature range of –5 to –40°C. Data from the viscometer drive module is collected and fed to a computerized data assimilation program to determine the Gelation Index, Gelation Index temperature, and Critical Pumpability temperature for a selected viscosity such as 30 000 or 40 000 mPa·s (cP).

#### 5. Significance and Use

5.1 *Significance of Low-Temperature, Low Shear Rate, Engine Oil Rheology*—The low-temperature, low-shear viscometric behavior of an engine oil determines whether the oil will flow to the sump inlet screen, then to the oil pump, then to the sites in the engine requiring lubrication in sufficient quantity to prevent engine damage immediately or ultimately after cold temperature starting.

5.1.1 Two forms of flow problems have been identified,<sup>4</sup> flow-limited and air-binding behavior. The first form of flow restriction, flow-limited behavior, is associated with the oil's viscosity; the second, air-binding behavior, is associated with gelation.

5.2 *Significance of the Test Method*—The temperature-scanning technique employed by this test method was designed to determine the susceptibility of the engine oil to flow-limited and air-binding response to slow cooling conditions by providing continuous information on the rheological condition of the oil over the temperature range of use.<sup>4, 5, 7</sup> In this way, both viscometric and gelation response are obtained in one test.

NOTE 1—This test method is one of three related to pumpability related problems. Measurement of low-temperature viscosity by the two other

<sup>6</sup> The test cell alignment device is covered by patents. Interested parties are invited to submit information regarding the identification of alternatives to this patented item to ASTM International Headquarters. Your comments will receive careful consideration at a meeting of the responsible technical committee, which you may attend.

<sup>7</sup> Shaub, H., "A History of ASTM Accomplishments in Low Temperature Engine Oil Rheology," *Symposium on Low Temperature Lubricant Rheology Measurement and Relevance to Engine Operation, ASTM STP 1143*, Rhodes, R. B., ed., ASTM, 1992, pp. 1-19.

pumpability Test Methods **D3829** and **D4684**, hold the sample in a quiescent state and generate the apparent viscosity of the sample at shear rates ranging up to 15 sec<sup>-1</sup> and shear stresses up to 525 Pa at a previously selected temperature. Such difference in test parameters (shear rate, shear stress, sample motion, temperature scanning, and so forth) can lead to differences in the measured apparent viscosity among these test methods with some test oils, particularly when other rheological factors associated with gelation are present. In addition, the three methods differ considerably in cooling rates.

5.3 *Gelation Index and Gelation Index Temperature*—This test method has been further developed to yield parameters called the Gelation Index and Gelation Index temperature. The first parameter is a measure of the maximum rate of torque increase caused by the rheological response of the oil as the oil is cooled slowly. The second parameter is the temperature at which the Gelation Index occurs.

#### 6. Apparatus<sup>3</sup>

6.1 Test Cell, shown in **Fig. 1**, consisting of a matched rotor and a stator of the following critical dimensions:

6.1.1 Rotor dimensions for: critical length is 65.5 mm (±0.1 mm) and critical diameter is 18.40 mm (±0.02 mm).

6.1.2 Stator dimensions for: critical diameter is 22.05 mm (±0.02 mm) at whatever length will satisfy the immersion depth when the upper oil level is a minimum of 15 mm below the cooling liquid level over the entire temperature range.

6.2 *Viscometer Drive Modules*, rotational viscometer drive modules capable of producing an analog signal to an analog-to-digital converter or other analog signal data processor such as a strip-chart recorder.

6.2.1 With the rotor and stator described in **6.1.1** and **6.1.2**, the viscometer drive module shall be capable of measuring to at least 45 000 mPa·s (cP).

6.3 *Test Cell Alignment Device*, simultaneously maintains a vertical axial alignment and reasonably consistent positioning of the rotor in the stator to give repeatable torque readout from test to test when setting up the apparatus for analysis.

6.3.1 *Viscometer Support*, supports the viscometer drive module and aligns it vertically.

6.3.2 *Stator Collar*, clamps the stator and supports it when the stator collar is attached to the viscometer support.

6.4 A means of providing a dry gas atmosphere over the top of the test sample is necessary to prevent condensation and freezing of water on the oil surface.

6.5 Programmable Liquid Cooling Bath, liquid bath capable of running either the calibration or the testing program with temperature control of ±0.1°C over the temperature range desired at 1°C/h.

6.5.1 *Temperature Controller*, is set up to operate according to two programs, the Calibration program and the test program. At any temperature the controller modulates temperature within 0.1°C of the desired value.

6.6 Computer, Analog-to-Digital Converter, and Analysis Program, means of receiving data from the viscometer drive module and converting this data into the desired information.

6.7 Sample Pre-treatment Water or Air Bath, a programmable water or air bath for both precise control of the test oils

at  $90 \pm 2^\circ\text{C}$  and immersion time after the sample reaches pre-treatment temperature.

6.8 Calibrated Partial-Immersion Mercury Thermometer, an ASTM 34C thermometer, calibrated at  $90^\circ\text{C}$  and reading to  $\pm 0.2^\circ\text{C}$ .

## 7. Materials<sup>3</sup>

7.1 *Calibration Oil*, a Newtonian calibration oil of specified dynamic viscosity and viscosity index over a temperature range of  $-5$  to  $-35^\circ\text{C}$ .

7.2 *Gelation Index Reference Oils, GIR-Series, Non-Newtonian Reference Oils*, having Gelation Indices of established values as well as related values for the Gelation Index temperatures.

7.3 *Finger Cots*, latex, used to close the top of the oil-filled stators when they are in the pre-treatment heating bath and subject to water condensation inside the stator.

## 8. Sampling

8.1 Approximately a 20 mL sample of test oil is necessary for the test.

## 9. Preparation of the Apparatus

9.1 Pre-treatment heating of samples using either a water bath or an oven.

9.1.1 *Water Baths*—Using boiling distilled water and correcting for barometric pressure (if significant because of altitude of the laboratory), check the calibration of the partial-immersion, calibrated mercury thermometer used in the pre-treatment water bath by appropriate methods.

9.1.1.1 Check the constant temperature of the pre-treatment water bath after ensuring that it is filled with distilled water to a level 20 mm above the oil level in the immersed stators. The temperature should be constant at  $90 \pm 2^\circ\text{C}$ .

9.1.2 *Ovens*—Check the calibration of the temperature sensing device by appropriate methods. The temperature should be constant at  $90 \pm 2^\circ\text{C}$ .

9.1.2.1 Determine the length of time required to bring the sample up to  $90^\circ\text{C}$ . Use this time interval to establish the length of time the sample is held in the oven before being poured into the stator.

9.2 *Preparing Liquid Cold-Bath*—Check the liquid level in the programmable liquid cold bath. Fill bath to proper depth according to supplier's instructions at  $-5^\circ\text{C}$ .

NOTE 2—To ensure adequate cooling fluid height above the sample, it is advisable to fill the bath at  $-5^\circ\text{C}$  to the appropriate level indicated by the manufacturer and to always bring the bath back to this temperature when on stand-by. This slows the evaporation rate. In addition, for many refrigerating baths, operation at some temperature moderately below room temperature maintains best operational response. Coolant should be added to the bath only at room temperatures to establish the correct fluid height as well as to avoid disruption of the cooling cycle at lower temperatures.

9.2.1 Install or check the cooling programs for the programmable liquid cold bath. The programs to be implemented are shown in **Tables 1 and 2**.

**TABLE 1 Program for Liquid Cold Bath to Obtain Calibration Information**

Step	Action	$^\circ\text{C}$	Time
1	Cool to $-5^\circ\text{C}$ and hold	-5	A
2	Set up data acquisition and initiate program	-5	A
3	Gather data at $-5^\circ\text{C}$	-5	30 m
4	Cool to $-10^\circ\text{C}$ and hold	-10	30 m
5	Cool to $-15^\circ\text{C}$ and hold	-15	30 m
6	Cool to $-20^\circ\text{C}$ and hold	-20	30 m
7	Cool to $-25^\circ\text{C}$ and hold	-25	30 m
8	Cool to $-30^\circ\text{C}$ and hold	-30	30 m
9	Cool to $-33^\circ\text{C}$ and hold	-33	30 m
10	Cool to $-35^\circ\text{C}$ and hold	-35	30 m
11	Return to $-5^\circ\text{C}$ and hold	-5	A

<sup>A</sup> Indeterminate, non-critical period.

**TABLE 2 Program for Liquid Cold Bath to Obtain Information on Test Oils**

Step	Action	$^\circ\text{C}$	Time
1	Cool to $-5^\circ\text{C}$ and hold	-5	A
2	Stabilize bath at $-5^\circ\text{C}$	-5	A
3	Set up data acquisition and initiate program	-5	A
4	Cool to $-40^\circ\text{C}$ or until 40 000 cP is reached	-5 to -40	$1^\circ\text{C}/\text{h}$
5	Return to $-5^\circ\text{C}$ and hold	-5	A

<sup>A</sup> Indeterminate, non-critical period.

9.3 Check to see that the upper hook threaded (left hand thread) to the viscometer drive module's driveshaft is firmly finger-tightened. In the tightening process gently and slightly *lift* the driveshaft.

NOTE 3—Do *not* pull down or push or pull laterally on the driveshaft as this may harm the internal jeweled bearing and perhaps bend the driveshaft as well.

## 10. Preparation for Calibration of the Test Cell

10.1 At room temperature pour the calibration oil, to the fill line (**Fig. 1**) of the stators to be calibrated and place in a suitable rack until ready.

NOTE 4—Since the calibration oil is Newtonian in behavior throughout the low temperature test range and thus is non-gelling, no special pre-heating preparation is necessary.

### 10.2 Computer Data Acquisition and Analysis.

10.2.1 For setting up a computer automated analysis, refer to the owner's manual.

10.3 Turn the programmable liquid cooling bath on to control at  $-5^\circ\text{C}$ .

## 11. Calibration of the Test Cell

### 11.1 Computer Method:

11.1.1 Set up cell and viscometer head as directed by the manufacturer using a reference Newtonian oil having an appropriate viscosity range and established as a standard for the test method.

11.1.2 Select special calibration cooling program shown in **Table 1** on programmable liquid cooling bath according to bath manufacturer's instructions but do not start the program.

11.1.3 Open and enter required viscosity and temperature data in computer program.

11.1.4 From 3.4, now open main flow control valve for dry gas flow above liquid in stator at approximate rate of 10 mL/min per cell.

11.1.5 Simultaneously initiate:

11.1.5.1 Cooling program on cold-bath and

11.1.5.2 Data recording on computer according to bath manufacturer's instructions.

11.1.6 Collect and analyze complete recorded data using program developer's instructions.

11.1.7 The slope value of the best line through the collected viscosity/percent maximum torque data should be greater than 450 and the correlation coefficient, R, should be  $R \geq 0.999$ . If not, another calibration run should be made to check the results and if no improvement is shown, the program developer or equipment manufacturer should be contacted for advice.

## 12. Preparation for Analysis of the Test Oil

12.1 Pour the test oil into the stator to the fill line on the stator (see Fig. 1) in preparation for pre-heating and cover with a suitable material (such as an unpowdered latex finger cot) to prevent any loss of more volatile components or condensation of moisture.

NOTE 5—A beaker may be used to pre-heat the test oil in an oven or in a water bath (if covered to prevent volatilization of components or condensation of moisture). In this case, pre-heated oils are to be poured into their respective stators within a few minutes after completing the pre-heating step.

12.1.1 Enter the identity of the test oils and test cells into the computer program according to the program instructions.

12.1.2 If using an oven for pre-heating, place samples in oven.

NOTE 6—A rack to hold the sample-containing stators is convenient for either ovens or water-baths.

12.1.3 If using a water bath for pre-heating, place the samples in the heating bath.

12.2 After the samples have reached  $90 \pm 2^\circ\text{C}$ , using the time determined in 9.1.2.1, hold at this temperature for 1.5 to 2.0 h.

12.2.1 After pre-heating, remove the samples from the oven or water bath, exercising care in handling the hot rack (if used) and samples. Remove covers over the samples at this time. Proceed to 13.4 as soon as the glass stators have cooled sufficiently for handling.

NOTE 7—Heating the rotor with the stator and test oil prolongs cooling considerably and is not acceptable for this protocol.

## 13. Procedure

13.1 *Bath Programming:*

13.1.1 Prepare to use special cooling program shown in Table 2 for testing unknown oils on programmable liquid cooling bath. Follow equipment manufacturer's instructions.

13.1.2 Set cooling bath to hold at  $-5^\circ\text{C}$  until test is begun.

13.2 Follow equipment manufacturer's instructions for entering identification of samples and sample cells into computer program.

NOTE 8—It is helpful to occasionally check operator technique and the functioning of the bath and other equipment by including and running a Gelation Index Reference oil having a known value of Gelation Index and Gelation Index temperature.

13.3 Follow Section 12 to properly preheat the oils in preparation for analysis.

NOTE 9—These preheating steps should be followed precisely as described.

13.4 Zero the viscometer head according to equipment manufacturer's instructions.

13.5 Insert matching, room-temperature rotor into the appropriate stator in preparation for joining the test cell to the adapter/viscometer head support and proceed immediately to remaining steps for preparation and cold-bath immersion.

13.6 Place test cell into test cell adapter according to manufacturer's instructions, taking care that no air bubbles are clinging to the bottom of the rotor when the cell and adapter are affixed to the viscometer head. If bubbles are noted after assembly, tip the assemblage to the side until the bubbles slide off the rotor bottom and hold upright again to permit bubbles to rise to the surface.

13.7 Fasten test cell and adapter to viscometer head after hooking rotor shaft to viscometer motor shaft.

13.8 Place the assembled test cell and viscometer head onto the programmable liquid bath. The samples should equilibrate in the cold bath at least 15 min but no longer than 30 min.

13.9 Set up the dry gas flow at approximately 10 mL/min. for each test cell.

13.10 Set the viscometer speed to 0.3 r/min.

13.11 Within 30 min of the time the first sample has been immersed in the bath, turn on the computer program and simultaneously initiate:

13.11.1 The cooling program on cold-bath and

13.11.2 Data recording on computer according to manufacturer's instructions.

13.12 At the conclusion of the test, use the computer program for data analysis and determination of critical pumpability temperature, Gelation Index, and Gelation Index temperature according to the manufacturer's directions.

NOTE 10—It is necessary to complete Section 11 for calibration of viscometer and cells before using the computer program or the program will not be able to accept information generated during the analysis of test oils.

## 14. Report

14.1 Report to the nearest tenth of a degree the temperature associated with each of the following viscosities:

5000 10 000 20 000 30 000 40 000 mPa·s (cP).

14.2 If there is a critical pumpability viscosity chosen as a criterion by the user of the test method, then report to the nearest tenth of a degree Celsius the critical pumpability temperature associated with it

NOTE 11—Past work<sup>7,8</sup> has indicated that, using this test method, either 40 000 or 30 000 mPa·s (cP) are indicative of engine pumpability requirements, depending on the engine manufacturer.

14.3 If the Gelation Index is greater than or equal to 6.0, report the Gelation Index to the nearest tenth of a unit, and the Gelation Index temperature to the nearest Celsius degree. If the Gelation Index is less than 6.0 report the value as less than 6.0 and do not report Gelation Index temperature.

NOTE 12—However, the test method generates values of Gelation Index values below 6 and these are useful in appraising instrument and operator consistency as well as providing other information.

## 15. Precision and Bias

15.1 The precision for critical pumpability temperatures derived from this round robin are as follows:

15.1.1 *Repeatability*—The difference between successive results obtained by the same operator with the same apparatus under constant operating conditions on identical test materials would, in the long run, in the normal and correct operation of the test method, exceed the following value in only one case in twenty:

Repeatability, 0.5°C

15.1.2 *Reproducibility*—The difference between two single and independent results obtained by different operators working in different laboratories on identical test materials would, in the long run, in the normal and correct operation of the test method, exceed the following value in only one case in twenty:

Reproducibility, 1.4°C

15.2 The precision for Gelation Index derived from this round robin are as follows:

15.2.1 *Repeatability*—The difference between successive results obtained by the same operator with the same apparatus under constant operating conditions on identical test materials would, in the long run, in the normal and correct operation of the test method, exceed the following value in only one case in twenty:

Repeatability (Gelation Index)—16 % of the mean value.

15.2.2 *Reproducibility*—The difference between two single and independent results obtained by different operators working in different laboratories on identical test materials would, in the long run, in the normal and correct operation of the test method, exceed the following value in only one case in twenty:

Reproducibility (Gelation Index)—29 % of the mean value

15.3 The precision for Gelation Index temperature derived from this round robin is as follows:

15.3.1 *Repeatability*—For oils with Gelation Index values greater than 6, the difference between successive results

obtained by the same operator with the same apparatus under constant operating conditions on identical test materials would, in the long run, in the normal and correct operation of the test method, exceed the following value in only one case in twenty:

Repeatability (Gelation Index temperature) 2°C

15.3.2 *Reproducibility*—For oils with Gelation Index values greater than 6, the difference between two single and independent results (larger minus smaller) obtained by different operators working in different laboratories on identical test materials would, in the long run, in the normal and correct operation of the test method, exceed the following value in only one case in twenty:

Reproducibility (Gelation Index temperature) 2°C

15.4 The interlaboratory program documented in RR D02-1448<sup>9</sup> included eight oils tested in 19 laboratories. The samples measured in the study covered the ranges of 5 000 to 40 000 mPa(s), 4.5 to 38.2 Gelation Index and -18.0 to -31.0 °C Gelation Index temperature.

15.5 The precision for viscosity derived from this round robin is as follows:

15.5.1 The difference between successive results obtained by the same operator with the same apparatus under constant operating conditions of identical test materials would, in the long run, in the normal and correct operation of the test method, exceed the following value in only one case in twenty:

Repeatability (Viscosity) = 16% of the mean value

15.5.2 The difference between two single and independent results obtained by different operators working in different laboratories on identical test materials would, in the long run, in the normal and correct operation of the test method, exceed the following value in only one case in twenty:

Reproducibility (Viscosity) = 26% of the mean value

15.6 The interlaboratory program documented in RR:D02-1511<sup>10</sup> included eight oils tested in 13 laboratories. The samples measured in the study covered the viscosity range from 5000 to 40 000 mPa(s).

15.7 There is no bias in test results or change in precision when this test method is run using TAV-II viscometer heads with DOS-based software versus when this test method is run using TAV-III viscometer heads with Windows-based software.<sup>11</sup>

## 16. Keywords

16.1 borderline pumping temperature; critical pumpability temperature; critical pumpability viscosity; engine oil; gelation; Gelation Index; Gelation Index temperature; low-temperature engine oil pumpability; low-temperature rheology; Scanning Brookfield technique; temperature-scanning technique; viscosity

<sup>9</sup> Supporting data have been filed at ASTM International Headquarters and may be obtained by requesting Research Report RR:D02-1448.

<sup>10</sup> Supporting data have been filed at ASTM International Headquarters and may be obtained by requesting Research Report RR:D02-1511.

<sup>11</sup> Supporting data have been filed at ASTM International Headquarters and may be obtained by requesting Research Report RR:D02-1568.

<sup>8</sup> Selby, T. W., "The Scanning Brookfield Technique of Low-Temperature, Low-Shear Rheology—Its Inception, Development, and Applications," *Low Temperature Lubricant Rheology Measurement and Relevance to Engine Operation*, ASTM STP 1143, Rhodes, R. B., ed., ASTM, 1992, pp. 33-64.