



Designation: D2158 – 11



Designation: 317/95

Standard Test Method for Residues in Liquefied Petroleum (LP) Gases¹

This standard is issued under the fixed designation D2158; the number immediately following the designation indicates the year of original adoption or, in the case of revision, the year of last revision. A number in parentheses indicates the year of last reapproval. A superscript epsilon (ϵ) indicates an editorial change since the last revision or reapproval.

1. Scope*

1.1 This test method covers the determination of extraneous materials weathering above 38°C that are present in liquefied petroleum gases. The extraneous materials will generally be dissolved in the LPG, but may have phase-separated in some instances.

1.2 Liquefied petroleum gases that contain certain anti-icing additives can give erroneous results by this test method.

1.3 Although this test method has been used to verify cleanliness and lack of heavy contaminants in propane for many years, it might not be sensitive enough to protect some equipment from operational problems or increased maintenance. A more sensitive test, able to detect lower levels of dissolved contaminants, could be required for some applications.

1.4 **WARNING**—Mercury has been designated by many regulatory agencies as a hazardous material that can cause central nervous system, kidney and liver damage. Mercury, or its vapor, may be hazardous to health and corrosive to materials. Caution should be taken when handling mercury and mercury containing products. See the applicable product Material Safety Data Sheet (MSDS) for details and EPA's website—<http://www.epa.gov/mercury/faq.htm>—for additional information. Users should be aware that selling mercury and/or mercury containing products into your state or country may be prohibited by law.

1.5 The values stated in SI units are to be regarded as standard. No other units of measurement are included in this standard.

1.6 *This standard does not purport to address all of the safety concerns, if any, associated with its use. It is the responsibility of the user of this standard to establish appropriate safety and health practices and determine the applicability of regulatory limitations prior to use.*

¹ This test method is under the jurisdiction of ASTM Committee D02 on Petroleum Products and Lubricants and is the direct responsibility of Subcommittee D02.H0 on Liquefied Petroleum Gas.

Current edition approved Jan. 1, 2011. Published February 2011. Originally approved in 1963. Last previous edition approved in 2005 as D2158–05. DOI: 10.1520/D2158-11.

2. Referenced Documents

2.1 *ASTM Standards*:²

D96 Test Method for Water and Sediment in Crude Oil by Centrifuge Method (Field Procedure) (Withdrawn 2000)³

D1796 Test Method for Water and Sediment in Fuel Oils by the Centrifuge Method (Laboratory Procedure)

D1835 Specification for Liquefied Petroleum (LP) Gases

E1 Specification for ASTM Liquid-in-Glass Thermometers

2.2 *Energy Institute Document*:

IP Test Methods - Appendix A. Specifications - IP standard thermometers⁴

3. Terminology

3.1 *Definitions of Terms Specific to This Standard*:

3.1.1 *oil stain observation, n*—the volume of solvent-residue mixture required to yield an oil stain or ring that persists for 2 minutes under specified conditions on absorbent paper.

3.1.2 *residue, n*—the volume, measured to the nearest 0.05 mL, of the residual material boiling above 38°C resulting from the evaporation of 100 mL of sample under the specified conditions of this test method.

3.1.3 *solvent-residue mixture, n*—a mixture (solution) of 10 mL of solvent with any residue remaining in the centrifuge tube at the conclusion of the first step in this test method.

4. Summary of Test Method

4.1 A 100-mL sample of liquefied petroleum gas is weathered in a 100-mL centrifuge tube. The volume of residue remaining after heating the tube to 38°C is measured and recorded.

4.2 To dissolve any residue, 10 mL of solvent is added to the centrifuge tube. Small, measured volumes of solvent-residue

² For referenced ASTM standards, visit the ASTM website, www.astm.org, or contact ASTM Customer Service at service@astm.org. For *Annual Book of ASTM Standards* volume information, refer to the standard's Document Summary page on the ASTM website.

³ The last approved version of this historical standard is referenced on www.astm.org.

⁴ Available from Energy Institute, 61 New Cavendish St., London, WIG 7AR, U.K. www.energyinstpubs.org.uk

*A Summary of Changes section appears at the end of this standard

mixture are deposited on an absorbent paper in a specified manner. The appearance of the absorbent paper to which the residue solution has been added in measured increments is observed and recorded.

5. Significance and Use

5.1 Control over the residue content (required by Specification D1835) is of considerable importance in end-use applications of LPG. In liquid feed systems residues can lead to troublesome deposits and, in vapor withdrawal systems, residues that are carried over can foul regulating equipment. Those that remain will accumulate, can be corrosive, and will contaminate following product. Water, particularly if alkaline, can cause failure of regulating equipment and corrosion of metals.

6. Interferences

6.1 Solid contaminants such as rust, scale or dirt can interfere with this test method, which is not intended for representative measurement of solid, undissolved contaminants.

7. Apparatus

7.1 *Centrifuge Tube*, 100-mL graduated, conforming to dimensions given in Fig. 1. The first 0.5 mL shall be graduated in 0.05-mL increments. The shape of the lower tip of the tube is especially important. The taper shall be uniform and the bottom shall be rounded as shown in Fig. 1. Tubes shall be made of thoroughly annealed heat-resistant glass. Volumetric graduation tolerances, based on air-free water at 20°C, are

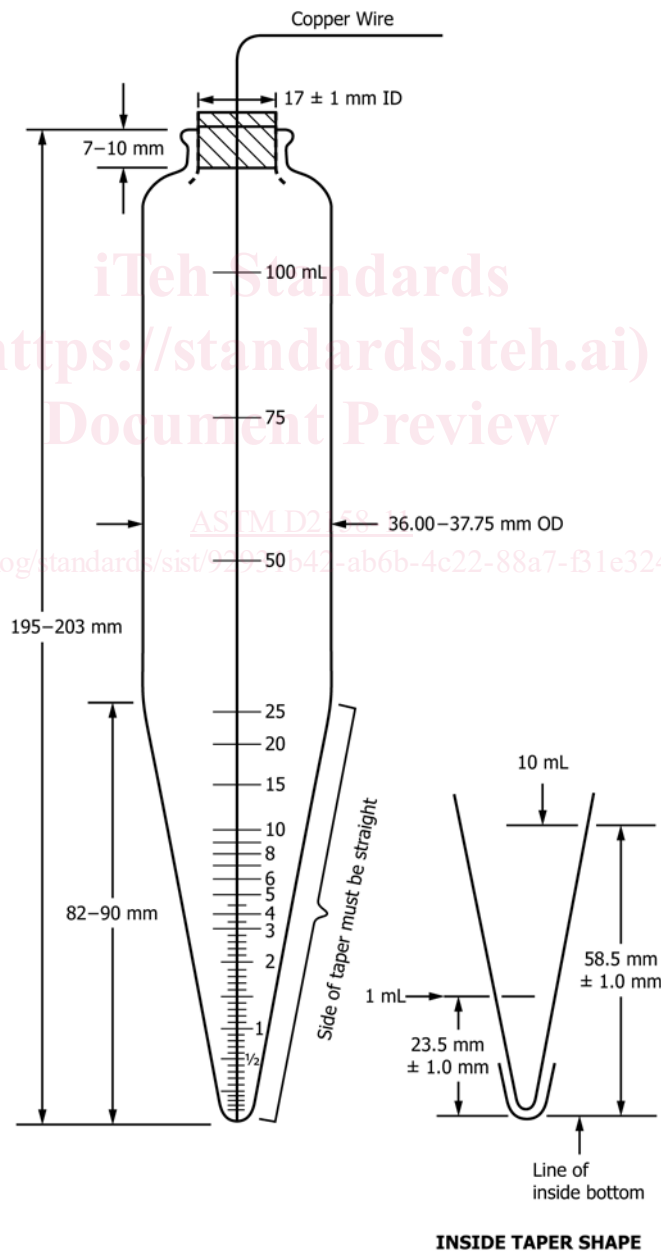

FIG. 1 Cone-Shaped Centrifuge Tube, 203 mm

given in Table 1. Detailed requirements for centrifuge tubes appear in Test Methods D96 and D1796.

7.2 *Cooling Coil and Cooling Bath*, a minimum length of 6 m of 5 to 7-mm outside diameter copper tubing wound to a diameter of 63.5 ± 1.5 -mm outside diameter, and assembled in a suitable cooling bath. (See Fig. 2 as an example.)

7.2.1 Mechanical refrigeration is permitted provided that the coolant temperature is below -43°C . If dry ice is used, a non-glass dewar or vessel is recommended.

7.3 *Syringe*, 2-mL graduated in 0.1 mL and equipped with a needle 200 ± 5 mm long. The needle may be either a sharp needle (ordinary medical syringe needle) or a safe, non-sharp syringe needle to avoid a puncture hazard. Alternatively, an equivalent liquid dispensing device capable of delivering 0.1-mL increments may be used, such as a 0.1-mL pipette.

7.4 *Temperature Measuring Device*, that is intrinsically safe, with accuracy equal to or better than Specification E1 or IP Test Methods - Appendix A shall be used. Thermometers conforming to Specification E1 or IP Appendix A have been found to be satisfactory.

Low Range	-38°C to $+50^{\circ}\text{C}$	IP 1C/ASTM 5C or IP 2C/ASTM 6C
High Range	-20°C to $+50^{\circ}\text{C}$	ASTM 57C

NOTE 1—When a thermometer or a water bath, or both, are not available, for example when conducting a field test, a satisfactory alternative for screening purposes is to warm the tip of the centrifuge tube with the hand.

7.4.1 For routine testing, a general purpose thermometer with 0.5°C subdivisions and a maximum scale error of 0.5°C may be used.

7.5 *Absorbent Paper*, white, at least 100-mm diameter. Medium grade or rapid filter paper has been found to be satisfactory. In this test method, the paper will be referred to as “filter paper.”

7.6 *Solvent Wash Bottle*, typically polyethylene.

7.7 *Water Bath*, controlled at $38 \pm 2^{\circ}\text{C}$.

7.8 *Copper Wire*, 1 to 2-mm diameter, at least 10 mm longer than the centrifuge tube’s height.

7.9 *Clamp*, suitable for holding the centrifuge tube during weathering.

8. Reagents and Materials

8.1 *Solvent*—HPLC-grade pentane or cyclopentane. Another grade of solvent may be used provided that it meets the requirements of 10.2.

TABLE 1 Centrifuge Tube Graduation Tolerances

Range, mL	Scale, Division, mL	Limit of Error, mL
0.0 to 0.1	0.05	0.02
0.1 to 0.3	0.05	0.03
0.3 to 0.5	0.05	0.05
0.5 to 1.0	0.1	0.05
1.0 to 3.0	0.1	0.1
3.0 to 5.0	0.5	0.2
5.0 to 25.0	1.0	0.5
25.0 to 100.0	1.0	1.0

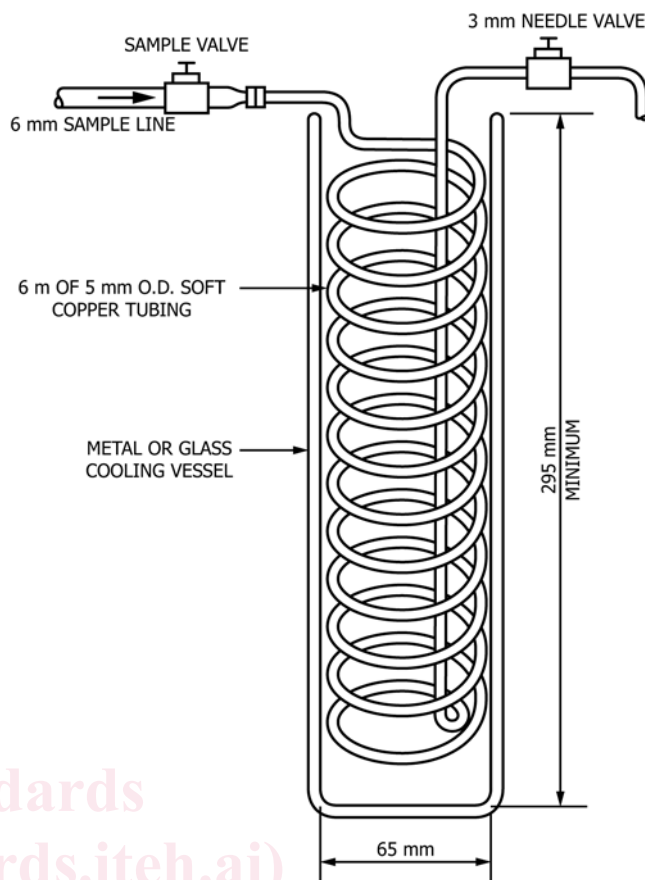

NOTE 1—Coils in the drawing are extended for clarity.

FIG. 2 Precooling Equipment

8.1.1 Although pentane is the preferred solvent for use in this test method, cyclopentane may be substituted for pentane whenever the ambient temperature or altitude is too high to enable the convenient handling of pentane.

8.1.2 Storage of solvent in a polyethylene wash bottle for several days contaminates the solvent. Therefore, do not use any solvent that has remained in a polyethylene wash bottle for more than one day.

9. Hazards

9.1 Note that there is a significant fire hazard from LPG vapors, and since the boiling point of LPG can be as low as -41°C , there is a risk of freezing “burns.” Take appropriate safety precautions to prevent ignition or fire, and wear suitable protective equipment to protect against skin contact with liquid or vaporizing LPG.

9.2 Operators should wear a grounded antistatic wrist strap. The use of an antistatic floor mat and grounding the sample cylinder are also advised.

10. Preparation of Apparatus

10.1 Wash all glassware that is to be used in the test in the selected solvent.

10.2 Verification of cleanliness of glassware and solvent.