



# Standard Practice for Underground Installation of Thermoplastic Pipe for Sewers and Other Gravity-Flow Applications<sup>1</sup>

This standard is issued under the fixed designation D2321; the number immediately following the designation indicates the year of original adoption or, in the case of revision, the year of last revision. A number in parentheses indicates the year of last reapproval. A superscript epsilon ( $\epsilon$ ) indicates an editorial change since the last revision or reapproval.

*This standard has been approved for use by agencies of the Department of Defense.*

## 1. Scope\*

1.1 This practice provides recommendations for the installation of buried thermoplastic pipe used in sewers and other gravity-flow applications. These recommendations are intended to ensure a stable underground environment for thermoplastic pipe under a wide range of service conditions. However, because of the numerous flexible plastic pipe products available and the inherent variability of natural ground conditions, achieving satisfactory performance of any one product may require modification to provisions contained herein to meet specific project requirements.

1.2 The scope of this practice necessarily excludes product performance criteria such as minimum pipe stiffness, maximum service deflection, or long term strength. Thus, it is incumbent upon the product manufacturer, specifier, or project engineer to verify and assure that the pipe specified for an intended application, when installed according to procedures outlined in this practice, will provide a long term, satisfactory performance according to criteria established for that application. A commentary on factors important in achieving a satisfactory installation is included in **Appendix X1**.

NOTE 1—Specific paragraphs in the appendix are referenced in the body of this practice for informational purposes.

NOTE 2—The following ASTM standards may be found useful in connection with this practice: Practice **D420**, Test Method **D1556**, Method **D2216**, Specification **D2235**, Test Method **D2412**, Specification **D2564**, Practice **D2657**, Practice **D2855**, Test Methods **D2922**, Test Method **D3017**, Practice **F402**, Specification **F477**, Specification **F545**, and Specification **F913**.

NOTE 3—Most Plumbing Codes and some Building Codes have provisions for the installation of underground “building drains and building sewers.” See them for plumbing piping applications.

1.3 *Units*—The values stated in inch-pound units are to be regarded as standard. The values given in parentheses are mathematical conversions to SI units that are provided for information only and are not considered standard.

1.4 *This standard does not purport to address all of the safety concerns, if any, associated with its use. It is the responsibility of the user of this standard to establish appropriate safety and health practices and determine the applicability of regulatory limitations prior to use.*

## 2. Referenced Documents

2.1 *ASTM Standards*:<sup>2</sup>

**D8 Terminology Relating to Materials for Roads and Pavements**

**D420 Guide to Site Characterization for Engineering Design and Construction Purposes (Withdrawn 2011)**<sup>3</sup>

**D653 Terminology Relating to Soil, Rock, and Contained Fluids**

**D698 Test Methods for Laboratory Compaction Characteristics of Soil Using Standard Effort (12 400 ft-lbf/ft<sup>3</sup> (600 kN-m/m<sup>3</sup>))**

**D1556 Test Method for Density and Unit Weight of Soil in Place by Sand-Cone Method**

**D2216 Test Methods for Laboratory Determination of Water (Moisture) Content of Soil and Rock by Mass**

**D2235 Specification for Solvent Cement for Acrylonitrile-Butadiene-Styrene (ABS) Plastic Pipe and Fittings**

**D2412 Test Method for Determination of External Loading Characteristics of Plastic Pipe by Parallel-Plate Loading**

**D2487 Practice for Classification of Soils for Engineering Purposes (Unified Soil Classification System)**

**D2488 Practice for Description and Identification of Soils (Visual-Manual Procedure)**

**D2564 Specification for Solvent Cements for Poly(Vinyl Chloride) (PVC) Plastic Piping Systems**

**D2657 Practice for Heat Fusion Joining of Polyolefin Pipe and Fittings**

**D2855 Practice for Making Solvent-Cemented Joints with Poly(Vinyl Chloride) (PVC) Pipe and Fittings**

<sup>1</sup> This practice is under the jurisdiction of ASTM Committee **F17** on Plastic Piping Systems and is the direct responsibility of Subcommittee **F17.62** on Sewer.

Current edition approved Feb. 1, 2011. Published March 2011. Originally approved in 1989. Last previous edition approved in 2009 as D2321 – 09. DOI: 10.1520/D2321-11.

<sup>2</sup> For referenced ASTM standards, visit the ASTM website, www.astm.org, or contact ASTM Customer Service at service@astm.org. For *Annual Book of ASTM Standards* volume information, refer to the standard's Document Summary page on the ASTM website.

<sup>3</sup> The last approved version of this historical standard is referenced on www.astm.org.

- D2922 Test Methods for Density of Soil and Soil-Aggregate in Place by Nuclear Methods (Shallow Depth) (Withdrawn 2007)<sup>3</sup>
- D3017 Test Method for Water Content of Soil and Rock in Place by Nuclear Methods (Shallow Depth)
- D3839 Guide for Underground Installation of “Fiberglass” (Glass-Fiber Reinforced Thermosetting-Resin) Pipe
- D4318 Test Methods for Liquid Limit, Plastic Limit, and Plasticity Index of Soils
- F402 Practice for Safe Handling of Solvent Cements, Primers, and Cleaners Used for Joining Thermoplastic Pipe and Fittings
- F412 Terminology Relating to Plastic Piping Systems
- F477 Specification for Elastomeric Seals (Gaskets) for Joining Plastic Pipe
- F545 Specification for PVC and ABS Injected Solvent Cemented Plastic Pipe Joints (Withdrawn 2001)<sup>3</sup>
- F913 Specification for Thermoplastic Elastomeric Seals (Gaskets) for Joining Plastic Pipe
- F1668 Guide for Construction Procedures for Buried Plastic Pipe

2.2 AASHTO Standard:<sup>4</sup>

- AASHTO M145 Classification of Soils and Soil Aggregate Mixtures

3. Terminology

3.1 *General*—Definitions used in this practice are in accordance with Terminologies F412 and D8 and Terminology D653 unless otherwise indicated.

3.2 *Definitions*:

3.2.1 Terminology D653 definitions used in this standard:

3.2.2 *compaction curve (Proctor curve) (moisture-density curve)*—the curve showing the relationship between the dry unit weight (density) and the water content of a soil for a given compactive effort.

3.2.3 *optimum water content* —the water content at which a soil can be compacted to a maximum dry unit weight by a given compactive effort.

3.2.4 *percent compaction*—the ratio, expressed as a percentage, of: (1) dry unit weight of a soil, to (2) maximum unit weight obtained in a laboratory compaction test.

3.2.5 *maximum unit weight*—the dry unit weight defined by the peak of a compaction curve.

3.3 *Definitions of Terms Specific to This Standard*:

3.3.1 *foundation, bedding, haunching, initial backfill, final backfill, pipe zone, excavated trench width*—See Fig. 1 for meaning and limits, and trench terminology.

3.3.2 *aggregate*—a granular material of mineral composition such as sand, gravel, shell, slag or crushed stone (see Terminology D8).

3.3.3 *deflection*—any change in the inside diameter of the pipe resulting from installation and imposed loads. Deflection

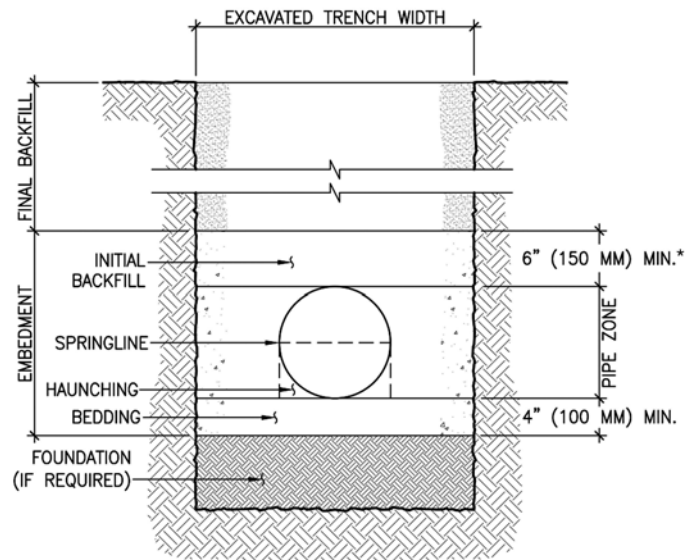

\* See 7.6 Minimum Cover

FIG. 1 Trench Cross Section

may be either vertical or horizontal and is usually reported as a percentage of the base (undeflected) inside pipe diameter.

3.3.4 *engineer*—the engineer in responsible charge of the work or his duly recognized or authorized representative.

3.3.5 *manufactured aggregates*—aggregates such as slag that are products or byproducts of a manufacturing process, or natural aggregates that are reduced to their final form by a manufacturing process such as crushing.

3.3.6 *modulus of soil reaction (E')*—an empirical value used in the Iowa deflection formula that defines the stiffness of the soil embedment around a buried pipe

3.3.7 *open-graded aggregate*—an aggregate that has a particle size distribution such that, when it is compacted, the voids between the aggregate particles, expressed as a percentage of the total space occupied by the material, are relatively large.

3.3.8 *processed aggregates*—aggregates that are screened, washed, mixed, or blended to produce a specific particle size distribution.

3.3.9 *secant constrained soil modulus (M<sub>s</sub>)*— a value for soil stiffness determined as the secant slope of the stress-strain curve of a one-dimensional compression test; M<sub>s</sub> can be used in place of E' in the Iowa deflection formula.

3.3.10 *standard proctor density*—the maximum dry unit weight of soil compacted at optimum moisture content, as obtained by laboratory test in accordance with Test Methods D698.

4. Significance and Use

4.1 This practice is for use by designers and specifiers, installation contractors, regulatory agencies, owners, and inspection organizations who are involved in the construction of sewers and other gravity-flow applications that utilize flexible thermoplastic pipe. As with any standard practice, modifications may be required for specific job conditions or for special local or regional conditions. Recommendations for inclusion of

<sup>4</sup> Available from American Association of State Highway and Transportation Officials (AASHTO), 444 N. Capitol St., NW, Suite 249, Washington, DC 20001, <http://www.transportation.org>.

this practice in contract documents for a specific project are given in **Appendix X2**.

## 5. Materials

5.1 *Classification*—Soil types used or encountered in burying pipes include those classified in **Table 1** and natural,

manufactured, and processed aggregates. The soil classifications are grouped into soil classifications in **Table 2** based on the typical soil stiffness when compacted. Class I indicates a soil that generally provides the highest soil stiffness at any given percent compaction, and provides a given soil stiffness with the least compactive effort. Each higher-number soil class

**TABLE 1 Soil Classification Chart (see Classification D2487)**

Criteria for Assigning Group Symbols and Group Names Using Laboratory Tests <sup>A</sup>				Soil Classification		
				Group Symbol	Group Name <sup>B</sup>	
Coarse-Grained Soils	gravels	clean gravels	$C_u \geq 4$ and $1 \leq C_c \leq 3^C$	GW	well-graded gravel <sup>D</sup>	
	More than 50% retained on No. 200 sieve	more than 50% of coarse fraction retained on No. 4 sieve	less than 5% of fines <sup>E</sup>	$C_u < 4$ and/or $1 > C_c > 3^C$	GP	poorly graded gravel <sup>D</sup>
			gravels with more than 12 % fines <sup>E</sup>	Fines classify as ML or MH	GM	silty gravel <sup>DFG</sup>
	sands	50% or more of coarse fraction passes on No. 4 sieve	clean sands	$C_u \geq 6$ and $1 \leq C_c \leq 3^C$	SW	well-graded sand <sup>H</sup>
			less than 5% fines <sup>I</sup>	$C_u < 6$ and/or $1 > C_c > 3^C$	SP	poorly graded sand <sup>H</sup>
			sand with fines	Fines classify as ML or MH	SM	silty sand <sup>FGH</sup>
	Fine-Grained Soils	silts and clays	inorganic	$PI > 7$ and plots on or above "A" line <sup>J</sup>	CL	lean clay <sup>KLM</sup>
$PI < 4$ and plots below "A" line <sup>J</sup>				ML	silt <sup>KLM</sup>	
liquid limit less than 50		organic	Liquid Limit-Oven dried	$< 0.75$	OL	organic clay <sup>KLMN</sup>
			Liquid Limit-Not dried			organic silt- <sup>KLMO</sup>
silts and clays		inorganic	$PI$ plots on or above "A" line	CH	fat clay <sup>KLM</sup>	
			Plots below "A" line	MH	elastic silt <sup>KLM</sup>	
liquid limit 50 or more	organic	Liquid Limit-Oven Dried	$< 0.75$	OH	organic clay <sup>KLMP</sup>	
		Liquid Limit-Not Dried			organic silt- <sup>KLMO</sup>	
Highly organic soils	primarily organic matter, dark in color, and organic odor			PT	peat	

<sup>A</sup> Based on the material passing the 3-in. (75-mm) sieve.

<sup>B</sup> If field sample contained cobbles or boulders, or both, add "with cobbles or boulders, or both" to group name.

<sup>C</sup>

$$C_u = \frac{D_{60}/D_{10}}{(D_{30})^2}$$

$$C_c = \frac{D_{10} \times D_{60}}{D_{30}^2}$$

<sup>D</sup> If soil contains  $\geq 15\%$  sand, add "with sand" to group name.

<sup>E</sup> Gravels with 5 to 12 % fines require dual symbols:

GW-GM well-graded gravel with silt:

GW-GC well-graded gravel with clay

GP-GM poorly graded gravel with silt

GP-GC poorly graded gravel with clay

<sup>F</sup> If fines classify as CL-ML, use dual symbol GC-GM, or SC-SM.

<sup>G</sup> If fines are organic, add "with organic fines" to group name.

<sup>H</sup> If soil contains  $\geq 15\%$  gravel, add "with gravel" to group name.

<sup>I</sup> Sands with 5 to 12 % fines require dual symbols:

SW-SM well-graded sand with silt

SW-SC well-graded sand with clay

SP-SM poorly graded sand with silt

SP-SC poorly graded sand with clay

<sup>J</sup> If Atterberg limits plot in hatched area, soil is a CL-ML, silty clay (see Test Method D4318).

<sup>K</sup> If soil contains 15 to 29 % plus No. 200, add "with sand" or "with gravel," whichever is predominant.

<sup>L</sup> If soil contains  $\geq 30\%$  plus No. 200, predominantly sand, add "sandy" to group name.

<sup>M</sup> If soil contains  $\geq 30\%$  plus No. 200, predominantly gravel, add "gravelly" to group name.

<sup>N</sup>  $PI \geq 4$  and plots on or above "A" line.

<sup>O</sup>  $PI < 4$  or plots below "A" line.

<sup>P</sup>  $PI$  plots on or above "A" line.

<sup>Q</sup>  $PI$  plots below "A" line.

**TABLE 2 Soil Classes**

Soil Group <sup>A,B</sup>	Soil Class	American Association of State Highway and Transportation Officials (AASHTO) Soil Groups <sup>C</sup>
Crushed rock, angular <sup>D</sup> : 100% passing 1-1/2in. sieve, $\leq$ 15 % passing #4 sieve, $\leq$ 25 % passing 3/8in. sieve and $\leq$ 12 % passing #200 sieve	Class I	...
Clean, coarse grained soils: SW, SP, GW, GP or any soil beginning with one of these symbols with $\leq$ 12 % passing #200 sieve <sup>E,F</sup>	Class II	A1,A3
Coarse grained soils with fines: GM, GC, SM, SC, or any soil beginning with one of these symbols, containing > 12 % passing #200 sieve; Sandy or gravelly fine-grained soils: CL, ML, or any soil beginning with one of these symbols, with $\geq$ 30 % retained on #200 sieve	Class III	A-2-4, A-2-5, A-2-6, or A-4 or A-6 soils with more than 30% retained on #200 sieve
Fine-grained soils: CL, ML, or any soil beginning with one of these symbols, with <30 % retained on #200 sieve	Class IV	A-2-7, or A-4, or A-6 soils with 30% or less retained on #200 sieve
MH, CH, OL, OH, PT	Class V Not for use as embedment	A5, A7

<sup>A</sup> See Classification **D2487**, Standard Classification of Soils for Engineering Purposes (Unified Soil Classification System).

<sup>B</sup> Limits may be imposed on the soil group to meet project or local requirements if the specified soil remains within the group. For example, some project applications require a Class I material with minimal fines to address specific structural or hydraulic conditions and the specification may read "Use Class I soil with a maximum of 5% passing the #200 sieve."

<sup>C</sup> AASHTO M145, Classification of Soils and Soil Aggregate Mixtures.

<sup>D</sup> All particle faces shall be fractured.

<sup>E</sup> Materials such as broken coral, shells, and recycled concrete, with  $\leq$  12% passing a No. 200 sieve, are considered to be Class II materials. These materials should only be used when evaluated and approved by the Engineer

<sup>F</sup> Uniform fine sands (SP) with more than 50% passing a No. 100 sieve (0.006 in., 0.15 mm) are very sensitive to moisture and should not be used as backfill unless specifically allowed in the contract documents. If use of these materials is allowed, compaction and handling procedures should follow the guidelines for Class III materials.

## Document Preview

provides successively less soil stiffness at a given percent compaction and requires greater compactive effort to provide a given level of soil stiffness

NOTE 4—See Practices **D2487** and **D2488** for laboratory and field visual-manual procedures for identification of soils.

NOTE 5—Processed materials produced for highway construction, including coarse aggregate, base, subbase, and surface coarse materials, when used for foundation, embedment, and backfill, should be categorized in accordance with this section and **Table 1** in accordance with particle size and gradation.

**5.2 Installation and Use**—**Table 3** provides recommendations on installation and use based on soil classification and location in the trench. Soil Classes I to IV should be used as recommended in **Table 3**. Soil Class V, including clays and silts with liquid limits greater than 50, organic soils, and frozen soils, shall be excluded from the pipe-zone embedment.

**5.2.1 Class I**—Class I materials provide maximum stability and pipe support for a given percent compaction due to the low content of sand and fines. With minimum effort these materials can be installed at relatively high-soil stiffnesses over a wide range of moisture contents. In addition, the high permeability of Class I materials may aid in the control of water, and these materials are often desirable for embedment in rock cuts where water is frequently encountered. However, when ground-water flow is anticipated, consideration should be given to the potential for migration of fines from adjacent materials into the open-graded Class I materials. (See **X1.8**.)

**5.2.2 Class II**—Class II materials, when compacted, provide a relatively high level of pipe support; however, open-graded groups may allow migration and the sizes should be checked for compatibility with adjacent material. (See **X1.8**.)

**5.2.3 Class III**—Class III materials provide less support for a given percent compaction than Class I or Class II materials. Higher levels of compactive effort are required and moisture content must be near optimum to minimize compactive effort and achieve the required percent compaction. These materials provide reasonable levels of pipe support once proper percent compaction is achieved.

**5.2.4 Class IV**—Class IV materials require a geotechnical evaluation prior to use. Moisture content must be near optimum to minimize compactive effort and achieve the required percent compaction. Properly placed and compacted, Class IV materials can provide reasonable levels of pipe support; however, these materials may not be suitable under high fills, surface-applied wheel loads, or under high-energy-level vibratory compactors and tampers. Do not use where water conditions in the trench may prevent proper placement and compaction.

NOTE 6—The term "high energy level vibratory compactors and tampers" refers to compaction equipment that might deflect or distort the pipe more than permitted by the specifications or the manufacturer.

**5.2.5 Class V**—Class V materials should be excluded from pipe-zone embedment.



**TABLE 3 Recommendations for Installation and Use of Soils and Aggregates for Foundation and Pipe-Zone Embedment**

Soil Class <sup>A</sup>	Class I <sup>B</sup>	Class II	Class III	Class IV
General Recommendations and Restrictions	Acceptable and common where no migration is probable or when combined with a geotextile filter media. Suitable for use as a drainage blanket and under drain where adjacent material is suitably graded or when used with a geotextile filter fabric (see X1.8).	Where hydraulic gradient exists check gradation to minimize migration. Clean groups are suitable for use as a drainage blanket and underdrain (see Table 2). Uniform fine sands (SP) with more than 50 % passing a #100 sieve (0.006 in., 0.15 mm) behave like silts and should be treated as Class IV soils.	Do not use where water conditions in trench prevent proper placement and compaction. Not recommended for use with pipes with stiffness of 9 psi or less	Difficult to achieve high-soil stiffness. Do not use where water conditions in trench prevent proper placement and compaction. Not recommended for use with pipes with stiffness of 9 psi or less
Foundation	Suitable as foundation and for replacing over-excavated and unstable trench bottom as restricted above.	Suitable as foundation and for replacing over-excavated and unstable trench bottom as restricted above. Install and compact in 12 in. (300 mm) maximum layers	Suitable for replacing over-excavated trench bottom as restricted above. Install and compact in 6 in. (150 mm) maximum layers	Suitable for replacing over-excavated trench bottom as restricted above. Install and compact in 6-in (150 mm) maximum layers
Pipe Embedment	Suitable as restricted above. Work material under pipe to provide uniform haunch support.	Suitable as restricted above. Work material under pipe to provide uniform haunch support.	Suitable as restricted above. Difficult to place and compact in the haunch zone.	Suitable as restricted above. Difficult to place and compact in the haunch zone.
Embedment Compaction: Min	See Note <sup>C</sup>	85 % (SW and SP soils) For GW and GP soils see Note <sup>E</sup>	90 %	95 %
Recommended Percent Compaction, SPD <sup>D</sup>				
Relative Compactive Effort Required to Achieve Minimum Percent Compaction	low	moderate	high	very high
Compaction Methods	vibration or impact	vibration or impact	impact	impact
Required Moisture Control	none	none	Maintain near optimum to minimize compactive effort	Maintain near optimum to minimize compactive effort

<sup>A</sup> Class V materials are unsuitable as embedment. They may be used as final backfill as permitted by the engineer.

<sup>B</sup> Class I materials have higher stiffness than Class II materials, but data on specific soil stiffness of placed, uncompacted Class I materials can be taken equivalent to Class II materials compacted to 95% of maximum standard Proctor density (SPD95), and the soil stiffness of compacted Class I materials can be taken equivalent to Class II materials compacted to 100% of maximum standard Proctor density (SPD100). Even if placed uncompacted (that is, dumped), Class I materials should always be worked into the haunch zone to assure complete placement.

<sup>C</sup> Suitable compaction typically achieved by dumped placement (that is, uncompacted but worked into haunch zone to ensure complete placement).

<sup>D</sup> SPD is standard Proctor density as determined by Test Method D698.

<sup>E</sup> Place and compact GW and GP soils with at least two passes of compaction equipment.

**5.3 Moisture Content of Embedment Materials**—The moisture content of embedment materials must be controlled to permit placement and compaction to required levels. For soils with low permeability (that is, Class III and Class IV and some borderline Class II soils), moisture content is normally controlled to  $\pm 3\%$  of optimum (see Test Method D698). The practicality of obtaining and maintaining the required limits on moisture content is an important criterion for selecting mate-

rials, since failure to achieve required percent compaction, especially in the pipe zone embedment, may result in excessive deflection.

**5.4 Maximum Particle Size**—Maximum particle size for embedment is limited to material passing a 1½-in. (37.5-mm) sieve (see Table 2). To enhance placement around small diameter pipe and to prevent damage to the pipe wall, a smaller

maximum size may be required (see X1.9). When final backfill contains rocks, cobbles, etc., the engineer may require greater initial backfill cover levels (see Fig. 1).

## 6. Trench Excavation

6.1 *General*—Procedures for trench excavation that are especially important in flexible thermoplastic pipe installations are given herein.

6.1.1 *Excavation*—Excavate trenches to ensure that sides will be stable under all working conditions. Slope trench walls or provide supports in conformance with all local and national standards for safety. Open only as much trench as can be safely maintained by available equipment. Backfill all trenches as soon as practicable, but not later than the end of each working day.

6.2 *Water Control*—Do not lay or embed pipe in standing or running water. At all times prevent runoff and surface water from entering the trench.

6.2.1 *Ground Water*—When groundwater is present in the work area, dewater to maintain stability of in-situ and imported materials. Maintain water level below pipe bedding and foundation to provide a stable trench bottom. Use, as appropriate, sump pumps, well points, deep wells, geofabrics, perforated underdrains, or stone blankets of sufficient thickness to remove and control water in the trench. When excavating while depressing ground water, ensure the ground water is below the bottom of cut at all times to prevent washout from behind sheeting or sloughing of exposed trench walls. Maintain control of water in the trench before, during, and after pipe installation, and until embedment is installed and sufficient backfill has been placed to prevent flotation of the pipe. To preclude loss of soil support, employ dewatering methods that minimize removal of fines and the creation of voids in in-situ materials.

6.2.2 *Running Water*—Control running water emanating from drainage of surface or ground water to preclude undermining of the trench bottom or walls, the foundation, or other zones of embedment. Provide dams, cutoffs or other barriers periodically along the installation to preclude transport of water along the trench bottom. Backfill all trenches after the pipe is installed to prevent disturbance of pipe and embedment.

6.2.3 *Materials for Water Control*—Use suitably graded materials in foundation or bedding layers or as drainage blankets for transport of running water to sump pits or other drains. Use well graded materials, along with perforated underdrains, to enhance transport of running water, as required. Select the gradation of the drainage materials to minimize migration of fines from surrounding materials (see X1.8).

6.3 *Minimum Trench Width*—Where trench walls are stable or supported, provide a width sufficient, but no greater than necessary, to ensure working room to properly and safely place and compact haunching and other embedment materials. The space between the pipe and trench wall must be wider than the compaction equipment used in the pipe zone. Minimum width shall be not less than the greater of either the pipe outside diameter plus 16 in. (400 mm) or the pipe outside diameter times 1.25, plus 12 in. (300 mm). In addition to safety considerations, trench width in unsupported, unstable soils will

depend on the size and stiffness of the pipe, stiffness of the embedment and in-situ soil, and depth of cover (see X1.10). Specially designed equipment may enable the satisfactory installation and embedment of pipe in trenches narrower than specified above. If it is determined that the use of such equipment provides an installation consistent with the requirements of this standard, minimum trench widths may be reduced, as approved by the engineer.

6.4 *Support of Trench Walls*—When supports such as trench sheeting, trench jacks, trench shields or boxes are used, ensure that support of the pipe and its embedment is maintained throughout installation. Ensure that sheeting is sufficiently tight to prevent washing out of the trench wall from behind the sheeting. Provide tight support of trench walls below viaducts, existing utilities, or other obstructions that restrict driving of sheeting.

6.4.1 *Supports Left in Place*—Unless otherwise directed by the engineer, sheeting driven into or below the pipe zone should be left in place to preclude loss of support of foundation and embedment materials. When top of sheeting is to be cut off, make cut 1.5 ft (0.5 m) or more above the crown of the pipe. Leave rangers, whalers, and braces in place as required to support cutoff sheeting and the trench wall in the vicinity of the pipe zone. Timber sheeting to be left in place is considered a permanent structural member and should be treated against biological degradation (for example, attack by insects or other biological forms) as necessary, and against decay if above ground water.

NOTE 7—Certain preservative and protective compounds may react adversely with some types of thermoplastics, and their use should be avoided in proximity of the pipe material.

6.4.2 *Movable Trench Wall Supports*—Do not disturb the installed pipe and its embedment when using movable trench boxes and shields. Movable supports should not be used below the top of the pipe zone unless approved methods are used for maintaining the integrity of embedment material. Before moving supports, place and compact embedment to sufficient depths to ensure protection of the pipe. As supports are moved, finish placing and compacting embedment.

6.4.3 *Removal of Trench Wall Support*—If the engineer permits the use of sheeting or other trench wall supports below the pipe zone, ensure that pipe and foundation and embedment materials are not disturbed by support removal. Fill voids left on removal of supports and compact all material as required.

6.5 *Rock or Unyielding Materials in Trench Bottom*—If ledge rock, hard pan, shale, or other unyielding material, cobbles, rubble or debris, boulders, or stones larger than 1.5 in. (40 mm) are encountered in the trench bottom, excavate a minimum depth of 6 in. (150 mm) below the pipe bottom and replace with proper embedment material (see 7.2.1).

## 7. Installation

7.1 *General*—Recommendations for use of the various types of materials classified in Section 5 and Table 2 for foundation, bedding, haunching and backfills, are given in Table 3.

NOTE 8—Installation of pipe in areas where significant settlement may be anticipated, such as in backfill adjacent to building foundations, and in