



Designation: D1683/D1683M – 11

Standard Test Method for Failure in Sewn Seams of Woven Apparel Fabrics¹

This standard is issued under the fixed designation D1683/D1683M; the number immediately following the designation indicates the year of original adoption or, in the case of revision, the year of last revision. A number in parentheses indicates the year of last reapproval. A superscript epsilon (ϵ) indicates an editorial change since the last revision or reapproval.

This standard has been approved for use by agencies of the Department of Defense.

1. Scope

1.1 This test method measures the sewn seam strength in woven fabrics by applying a force perpendicular to the sewn seams.

NOTE 1—The grab test procedure in Test Method D5034 shall be used to determine any characteristic in fabric that can affect the measurement of sewn seam strength.

1.1.1 This test method is applicable to sewn seams obtained from a previously sewn article or seams sewn with fabric samples using either a specific seam assembly (see Table 1), or production seam assemblies.

1.2 This test method is used when a breaking force to rupture, a minimum elongation, or both are required to determine the sewn seam strength, seam slippage, or seam integrity of a particular fabric for a specified end use.

NOTE 2—This test method is used in conjunction with Test Method D5034, which is used to measure breaking force and elongation of textile fabrics. Sewn seams in woven fabrics can fail due to rupture, slippage, or any combination thereof. Rupture can be further categorized as failure of fabric, or sewing thread, or seam slippage.

1.3 This test method does not predict actual wear performance of a seam.

1.4 The values stated in either SI units or inch-pound units are to be regarded separately as standard. The values stated in each system may not be exact equivalents; therefore, each system shall be used independently of the other. Combining values from the two systems may result in non-conformance with the standard.

1.5 *This standard does not purport to address all of the safety concerns, if any, associated with its use. It is the responsibility of the user of this standard to establish appropriate*

appropriate safety and health practices and determine the applicability of regulatory limitations prior to use.

2. Referenced Documents

2.1 *ASTM Standards:*²

D76 Specification for Tensile Testing Machines for Textiles

D123 Terminology Relating to Textiles

D1776 Practice for Conditioning and Testing Textiles

D5034 Test Method for Breaking Strength and Elongation of Textile Fabrics (Grab Test)

D5822 Test Method for Determining Seam Strength in Inflatable Restraint Cushions

D6193 Practice for Stitches and Seams

3. Terminology

3.1 *Definitions:*

3.1.1 *needle damage, n*—in sewn fabrics, the partial or complete yarn severance or fiber fusing caused by a needle passing through a fabric during sewing.

3.1.2 *seam allowance, n*—in sewn fabrics, the distance from the edge of a fabric to the parallel stitch line furthest from that edge.

3.1.3 *seam assembly, n*—the composite structure obtained when fabric(s) are joined by means of a seam.

3.1.3.1 *Discussion*—A seam assembly may be described in terms of fabric orientation, seam direction, seam type, stitch type, seam allowance, sewing thread tex number(s) and type(s) stitch density, stitch gage, and rows of stitching.

3.1.4 *seam efficiency, n*—in sewn fabrics, the ratio, expressed as a percentage, of the breaking force required to rupture a sewn seam to that required to rupture the fabric.

3.1.5 *seam engineering, n*—in sewn fabrics, the procedures used to select a specific combination of sewing thread, stitch

¹ This test method is under the jurisdiction of ASTM Committee D13 on Textiles and is the direct responsibility of Subcommittee D13.54 on Subassemblies.

Current edition approved Feb. 1, 2011. Published March 2011. Originally approved in 1990. Discontinued in 1999 and reinstated in 2004 as D1683–04. Last previous edition approved in 2007 as D1683–07. DOI: 10.1520/D1683_D1683M-11.

² For referenced ASTM standards, visit the ASTM website, www.astm.org, or contact ASTM Customer Service at service@astm.org. For *Annual Book of ASTM Standards* volume information, refer to the standard's Document Summary page on the ASTM website.

TABLE 1 Standard/Default Seam Assembly Specification^A

Fabric: High Density Warp and Filling Yarn Construction made of Fine Count Yarns		
Mass	up to 270 g/m ² [8 oz/yd ²]	over 270 g/m ² [8 oz/yd ²]
Seam allowance	13 mm [0.5 in.]	16 mm [0.625 in.]
Needle:		
Size	Metric 90 [0.036 in.]	Metric 110 [0.044 in.]
Finish	chrome	chrome
Point	thin ball (No.1/No. 23)	medium ball (No. 23/No. 43)
Sewing thread size:		
Cotton	Tex 35	Tex 70
Polyester-core	Tex 40	Tex 60
Seam Type	Ssa-1	Ssa-1
Stitch Type	301	301
Stitch Density	4.7 ± ½ stitches per centimetre [12 ± ½ stitches per inch]	3.1 ± ½ stitches per centimetre [8 ± ½ stitches per inch]
Fabric: Medium Density Warp and Filling Yarn Construction made of Fine to Medium Count Yarns		
Mass	up to 270 g/m ² [8 oz/yd ²]	over 270 g/m ² [8 oz/yd ²]
Seam Allowance	25 mm [1 in.]	25 mm [1 in.]
Needle:		
Size	Metric 110 [0.044 in.]	Metric 140 [0.054 in.]
Finish	chrome	chrome
Point	medium ball (No. 43/No. 44)	medium ball (No. 43/No. 44)
Sewing Thread:		
Cotton	Tex 70	Tex 105
Polyester-core	Tex 60	Tex 90
Seam type	SSn-2	SSn-2
Stitch type	301	301
Stitch density	4.7 ± ½ stitches per centimetre [12 ± ½ stitches per inch]	3.1 ± ½ stitches per centimetre [8 ± ½ stitches per inch]
Fabric: Low Density Warp and Filling Yarn Construction made of Medium to Heavy Count Yarns		
Mass	up to 270 g/m ² [8 oz/yd ²]	over 270 g/m ² [8 oz/yd ²]
Seam allowance	40 mm [1.5 in.]	40 mm [1.5 in.]
Needle:		
Size	Metric 110 [0.044 in.]	Metric 140 [0.054 in.]
Finish	chrome	chrome
Point	medium ball (No. 44)	heavy ball (No. 45)
Sewing thread size:		
Cotton	Tex 70	Tex 105
Polyester-core	Tex 60	Tex 90
Seam type	SSd-2	SSd-2
Stitch type	401	401
Stitch density	4.7 ± ½ stitches per centimetre [12 ± ½ stitches per inch]	3.1 ± ½ stitches per centimetre [8 ± ½ stitches per inch]

^A A complete description of seam types and stitch types can be found in Practice D6193. <https://standards.iteh.ai/>

type, seam type, and stitch density to achieve the maximum sewn seam strength for a particular fabric type.

3.1.6 *seam failure, n—in sewn fabrics*, that point at which an external force (1) ruptures the sewing thread, (2) ruptures the fabric, (3) causes excessive yarn slippage adjacent to the stitches, or (4) causes any combination of these unacceptable conditions.

3.1.6.1 *Discussion*—Despite the lack of rupture, excessive seam slippage will either significantly reduce seam efficiency, or, result in an unsightly appearance thus creating seam failure.

3.1.7 *seam slippage, n—in sewn fabrics*, a mode of failure in production seams.

3.1.7.1 *Discussion*—Shown as a transverse ratio of junction strength to fabric strength including the ratio of elongation of fabric to the ratio of elongation at the junction. Seam slippage, occurs when fabric yarns parallel to the stitch line move away from the seam. It is caused by the yarns in the fabric pulling out from the stitch line, and manifests itself as a gaping opening. Any movement of the warp and weft yarns away from a seam line under transverse stresses, which exacerbate the potential damage. (See *yarn slippage*.)

3.1.8 *seam type, n—in sewn fabrics*, an alphanumeric designation relating to the essential characteristics of fabric positioning and rows of stitching in a specified sewn fabric seam.

3.1.8.1 *Discussion*—The first two letters of the designation show seam type; the third and subsequent letters specify a particular mating alignment; the number designation indicates the number of rows of stitches.

3.1.9 *sewn seam, n—in sewn fabrics*, a juncture at which two or more planar structures such as textile fabrics, are joined by sewing, usually near the edge.

3.1.10 *sewn seam strength, n—in sewn fabrics*, the maximum resistance to rupture of the junction formed by stitching together two or more planar structures.

3.1.11 *slippage, n—in sewn fabrics*, the displacement of one or more fabric yarns from their original position, so as to cause differences in alignment, spacing or both.

3.1.12 *standard seam, n—a seam assembly* which uses a specific seam type for a designated fabric having specific weight, density and construction, as shown in Table 1.

3.1.13 *stitch, n*—in sewn seams, the repeated unit formed by the sewing thread(s) in the production of seams.

3.1.14 *stitch density, n*—in sewn fabrics, the number of stitches per unit length in one row of stitching.

3.1.15 *stitch gage, n*—in sewn fabrics, the perpendicular distance between adjacent parallel rows of stitching.

3.1.16 *stitch type, n*—a numerical designation relating to the essential characteristics of the interlacing of sewing thread(s) in a specified stitch.

3.1.16.1 *Discussion*—Stitch types are described in Practice D6193.

3.1.17 *yarn slippage, n*—a mode of failure of fabrics when sewn using a standard seam.

3.1.17.1 *Discussion*—The displacement of one or more fabric yarns from the original position(s) so as to cause differences in alignment and spacing of both yarns.

3.2 For definitions of other textile terms used in this test method, refer to Terminology D123.

4. Summary of Test Method

4.1 This test method can also be used to measure seam slippage by subtracting the elongation of the fabric from that of the fabric with a seam in it.

4.2 The applied force is longitudinal and perpendicular to the seam.

4.2.1 A force is applied until seam failure occurs.

5. Significance and Use

5.1 This test method can also be used to determine either the sewn seam strength of textiles or the efficiency of a seam assembly with any given fabric. Additionally, the seam strengths of different fabrics can be compared directly by using one of the standard seam assemblies specified in Table 1. Because current information about laboratory precision is incomplete, comparative tests may be advisable.

5.1.1 In case of dispute arising from differences in reported test results when using this test method for acceptance testing of commercial shipments, the purchaser and the supplier should perform comparative tests to determine if there is a statistical bias between their laboratories. Competent statistical assistance is recommended for the investigation of bias. As a minimum, the two parties should take a group of test specimens from the same lot of fabric to be evaluated, which utilize a like seam assembly (or standard seam assembly). The test specimens should then be randomly assigned in equal numbers to each laboratory for testing. If a bias is found, either its cause must be determined and corrected, or the purchaser and supplier must agree to interpret future test results in light of the known bias.

5.2 This test method determines the seam efficiency of a specified seam assembly with each fabric. Because seam efficiency varies with each fabric, one of the standard seam assemblies, as noted in Table 1, should be used when comparing the seam strength of different fabrics. Table 1 lists the default seam assembly specifications to be used for fabrics made with fine, medium and heavy count yarns. If a determination cannot be made as to which seam is the best suited for a particular fabric, all should be evaluated.

5.3 Seams prepared for this test method should be made by competent factory sewing operators familiar with the potential for damage to the integrity of the sewn seam when stitching is improperly done. (See Note 2.)

NOTE 3—If competent factory sewing operators are not accessible, a laboratory technician familiar with the potential for damage of an improperly sewn seam may prepare the seamed test specimens. It is imperative for purchaser/supplier to understand the impact an improperly sewn seam will have on test results.)

5.4 This test method is applicable whenever a determination of effective sewn seam strength, that is, the optimum seam interaction, is required. The breaking force of the seam and fabric will permit determination of seam efficiency. This test method can aid in determining optimum seam interaction for any given fabric by comparing the properties of the fabric with and without seams.

5.5 Seam engineering techniques for specific fabric types can also be determined by utilizing this test method.

5.6 This test method can be used to determine when the sewn seam is affected by seam slippage. While the ultimate consequence of this phenomenon is rupture, seam slippage greater than either the values stated in customer specifications, or as agreed upon by purchaser/supplier may severely reduce the integrity such that the product cannot be used for its intended purpose. (An example of a commonly used seam slippage value is 6 ± 1 mm [0.25 ± 0.04 in.].)

6. Apparatus

6.1 *Tensile Testing Machine*, as used in Test Method D5034 conforming to Specification D76, and preferably a constant-rate-of-extension (CRE) type of machine capable of jaw separation rate of 305 ± 10 mm/min [12.0 ± 0.5 in./min] and an adequate pen or interfaced computer response to record the force-extension curve. When a CRE type of machine is not used, a constant-rate-of-traverse (CRT) type of machine. (See Note 4.)

NOTE 4—In cases of dispute a constant-rate-of-extension (CRE) type machine should be used to referee testing. Because of the biases between test results for these types of tensile testing machine, report the name, type and date of calibration of the machine used.)

6.1.1 At least one clamp should be supported by a free swivel or universal joint to allow the clamp to rotate in the plane of the fabric.

6.1.2 *Back Jaws*, 25 ± 1 mm [1 ± 0.04 in.], parallel to direction of force application by not less than 50 ± 1 mm [2 ± 0.04 in.] perpendicular to direction of force application. (See Note 5.)

NOTE 5—Front (or top) faces measuring 25 ± 1 by 50 ± 1 mm [1.0 ± 0.04 by 2.0 ± 0.04 in.] will not necessarily give the same value as 25 ± 1 by 25 ± 1 mm [1.0 ± 0.04 by 1.0 ± 0.04 in.] faces. For many materials, the former are preferable because of the larger gripping area which tends to reduce slippage. While both sizes of gripping surface are permitted, the face sizes used must be the same for all samples in the test and must be recorded in the report.

6.1.3 *Front Jaws*, 25 ± 1 by 25 ± 1 mm [1 ± 0.04 by 1 ± 0.04 in.].

6.2 *Sewing Machine*, with any necessary accessories capable of handling the test fabric and forming the required seam(s) and stitch types.

6.3 *Sewing Threads*, to be either of required type, materials, and tex size as determined by purchaser and supplier, or of the type, materials, and tex size specified for standard seams in [Table 1](#).

6.4 *Dividers*, one pair.

6.5 *Metal Rule*, graduated in 1-mm [0.03125-in.] subdivisions.

7. Sampling Manufactured Items

7.1 Specimens can be taken from either previously sewn seam or from structures made with sewn seams as noted in [Table 1](#), or using a seam assembly as agreed to between purchaser and supplier.

7.2 *Lot Sample for Manufactured Items*—As a lot sample for acceptance testing, take at random, the number of shipping units of manufactured items containing sewn seams as directed in a material specification or other agreement between the purchaser and the supplier. (See [Note 6](#).)

NOTE 6—An adequate specification or other agreement between the purchaser and supplier requires taking into account the variability between cartons of previously manufactured items or rolls of fabric from which sewn seam will be prepared; and between specimens from a carton of manufactured items or prepared constructions to produce a sampling plan with a meaningful producer’s risk and consumer’s risk, while at the same time providing acceptable quality and limited quality levels.)

7.3 *Laboratory Sample for Manufactured Items*—Take sufficient manufactured items from each carton of a lot sample as to provide adequate laboratory samples and adequate specimens for each assembly being evaluated. If more than one type of seam assembly exists in the laboratory samples, the choice of seam assembly to be evaluated must be agreed upon by the purchaser and supplier.

7.4 *Test Specimens from Manufactured Items*—Cut five test specimens for each specified seam assembly in each of the warp and fill directions (where applicable) from the specified manufactured item(s) in the laboratory sample. Cut each specimen to a total length of 350 ± 3 mm [14 ± 0.1 in.] perpendicular to the proposed seam, with 250 ± 3 mm [10 ± 0.1 in.] on one side of the seam and 100 ± 3 mm [4 ± 0.1 in.] on the opposite site of the seam, and a width of 100 ± 3 mm [4 ± 0.1 in.] parallel to the stitch line(s) of the seam. (See [Fig. 1](#).) If the required number of specimens cannot be cut from each laboratory sampling unit or if there is more than one seam in the laboratory sampling units, modify the sampling plan as agreed between the supplier and purchaser. (See [Note 7](#).)

NOTE 7—When the specimen length of 350 ± 3 mm [14 ± 0.1 in.] is not attainable so as to provide sufficient length of fabric perpendicular to the seam, to allow adequate seam strength testing and fabric strength testing, a modification must be agreed to between purchaser and supplier. A comparison of the fabric break strength as determined by Test Method [D5034](#), of the two fabric swatches used in the seaming to the sewn strength of the seam assembly is required to produce a value indicative of the seam efficiency.

8. Sampling of Seams Prepared from Fabric

8.1 *Lot Sample for Fabric*—As a lot sample for acceptance testing, take at random the number of rolls of fabric directed in an applicable material specification or other agreement between the purchaser and supplier.

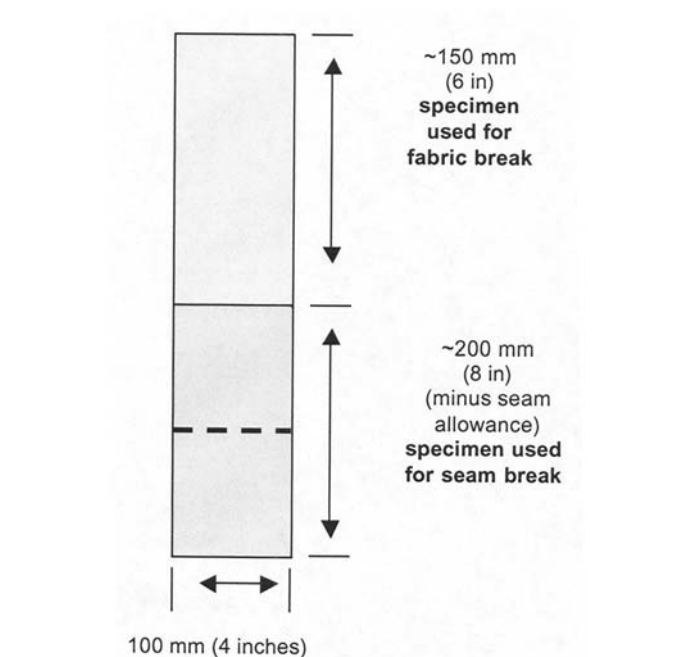

FIG. 1 Seamed Specimen Removed from Manufactured Item

8.2 *Laboratory Sample for Fabric*—After discarding 1 ± 0.1 m [1 ± 0.1 yd] from the outside roll, take a swatch 3 ± 0.1 m [3 ± 0.1 yd] in length and the full width of the fabric to construct an adequate quantity of the seam assembly, which is to be evaluated.

8.2.1 *Specimen Preparation*—As a source of test specimens, cut five specimens 350 ± 3 mm [14 ± 0.1 in.] by 100 ± 3 mm [4 ± 0.1 in.] with their long dimensions parallel either to the warp (machine) direction or to the filling (cross) direction, or cut specimens for testing from both directions if required. (See [Fig. 2](#).) Preferably specimens for a given fabric direction should be spaced along a diagonal of the fabric to allow for representation of different warp and filling yarns, or machine and cross direction areas, in each specimen. When possible, filling specimens should contain yarn from widely separated filling areas. Unless otherwise specified, take specimens no nearer to the selvage, or edge of the fabric, than one tenth of the width of the fabric. Depending on the direction in which seam strength is to be tested, sew swatch as follows:

8.2.2 Fold the specimen 100 ± 3 mm [4 ± 0.1 in.] from one end with the fold parallel to the short direction of the fabric. Sew a seam as agreed upon by purchaser and supplier ([Note 8](#)). (See [Fig. 3](#).)

NOTE 8—In the absence of an agreement on the construction of a seam assembly, prepare a standard seam using the specifications from [Table 1](#). These seam assembly specifications are categorized by fabric weight, yarn density and construction, as shown in [Table 1](#). These default seam assemblies are to be used when production seams are not available, or specified.

8.2.3 After seaming, cut the fold open. The test specimen should contain a seam approximately 100 ± 3 mm [4 ± 0.1 in.] from one end. Each test specimen will contain sufficient material for one seamed and one fabric test. (See [Fig. 1](#).)