



Designation: D2010/D2010M – 98 (Reapproved 2010)

Standard Test Methods for Evaluation of Total Sulfation Activity in the Atmosphere by the Lead Dioxide Technique¹

This standard is issued under the fixed designation D2010/D2010M; the number immediately following the designation indicates the year of original adoption or, in the case of revision, the year of last revision. A number in parentheses indicates the year of last reapproval. A superscript epsilon (ϵ) indicates an editorial change since the last revision or reapproval.

This standard has been approved for use by agencies of the U.S. Department of Defense.

1. Scope

1.1 These test methods describe the evaluation of the total sulfation activity in the atmosphere. Because of its oxidizing power, lead dioxide (PbO_2) converts not only sulfur dioxide (SO_2), but other compounds, such as mercaptans and hydrogen sulfide, into sulfate. It fixes sulfur trioxide and sulfuric acid mist present in the atmosphere (see **Note 1**).

1.2 Test Method A describes the use of a PbO_2 candle, and Test Method B describes that of a PbO_2 sulfation plate.²

1.3 These test methods provide a weighted average effective SO_2 level for a 30-day interval.

1.4 The results of these test methods correlate approximately with volumetric SO_2 concentrations, although the presence of dew or condensed moisture tends to enhance the capture of SO_2 onto the candle or plate.

1.5 The values stated in SI units shall be regarded as the standard. The values given in brackets are for information only and may be approximate.

NOTE 1—It has been shown that the rate constant of the chemical reaction between SO_2 and PbO_2 is independent of the concentration of SO_2 up to levels of 1000 ppm(v), if 15 % or less of the PbO_2 has been reduced (**1**).³ 15 % of the PbO_2 is equivalent to 11 to 12 mg of SO_2/cm^2 per day.

1.6 *This standard does not purport to address all of the safety concerns, if any, associated with its use. It is the responsibility of the user of this standard to establish appropriate safety and health practices and determine the applicability of regulatory limitations prior to use.* For specific precautionary statements, see Section 8.

¹ These test methods are under the jurisdiction of ASTM Committee D22 on Air Quality and are the direct responsibility of Subcommittee D22.03 on Ambient Atmospheres and Source Emissions.

Current edition approved Oct. 1, 2010. Published March 2011. Originally approved in 1962. Last previous edition approved in 2004 as D2010/D2010M – 98 (2004). DOI: 10.1520/D2010_D2010M-98R10.

² Test Method B has been adapted from Test Method G91, which is under the jurisdiction of ASTM Committee D22 on Air Quality and is the direct responsibility of Subcommittee D22.03 on Ambient Atmospheres and Source Emissions.

³ The boldface numbers in parentheses refer to the list of references at the end of this standard.

2. Referenced Documents

2.1 *ASTM Standards*:⁴

D516 Test Method for Sulfate Ion in Water

D1193 Specification for Reagent Water

D1356 Terminology Relating to Sampling and Analysis of Atmospheres

D1357 Practice for Planning the Sampling of the Ambient Atmosphere

G91 Practice for Monitoring Atmospheric SO_2 Deposition Rate for Atmospheric Corrosivity Evaluation

3. Terminology

3.1 *Definitions*—For definitions of terms used in these test methods, refer to Terminology D1356.

3.2 *Definitions of Terms Specific to This Standard*:

3.2.1 *sulfation*—the process by which sulfur-containing compounds are oxidized by the action of PbO_2 .

3.2.2 *sulfation activity*—the capture rate of sulfur-containing compounds as they are oxidized by PbO_2 under the conditions of these test methods.

4. Summary of Test Methods

4.1 *Test Method A*—Inert cylinders are coated with PbO_2 paste and exposed to the atmosphere for an extended period of time, usually one month. Sulfur oxides react chemically with the paste, forming lead sulfate (PbSO_4) (**1-5**).

4.2 *Test Method B*—Sulfation plates consisting of a PbO_2 paste in an inverted dish are likewise exposed to the atmosphere (**6**).

4.3 *Test Methods A and B*—The cylinders or plates are returned to a laboratory after the sampling period; the paste is removed and suspended in hot sodium carbonate (Na_2CO_3) solution to dissolve the PbSO_4 and convert the sulfate to soluble sodium sulfate (Na_2SO_4). The Na_2SO_4 solution is

⁴ For referenced ASTM standards, visit the ASTM website, www.astm.org, or contact ASTM Customer Service at service@astm.org. For *Annual Book of ASTM Standards* volume information, refer to the standard's Document Summary page on the ASTM website.

separated from the PbO₂ slurry by filtration. The sulfate is determined by precipitation with barium chloride (BaCl₂) (7).

4.4 The chemistry of the process is illustrated, for the case of SO₂, in the following reactions:

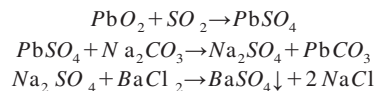

5. Significance and Use

5.1 Sulfur oxide gases are produced during the combustion of materials containing sulfur. These gases are precursors of atmospheric sulfuric acid, which has been shown to be injurious to living creatures and plants, as well as some inanimate materials such as metals, limestone and sandstone building materials.

5.2 Sulfur dioxide is moderately toxic and strongly phytotoxic to many species. Permissible ambient levels of SO₂ have been established by law.

5.3 When it is necessary to establish whether ambient air concentrations of sulfuric acid precursors, such as sulfur oxides, are present and to comply with legal criteria, manual and automatic monitoring systems specific for the individual sulfur species are used. Likely locations for monitoring sites for the estimation of concentrations and concentration trends over long periods of time can be screened conveniently using the PbO₂ candles or sulfation plates.

5.4 Atmospheric corrosion of metallic materials is a function of many weather and atmospheric variables. The effect of specific corrodants, such as SO₂, can accelerate the atmospheric corrosion of metals or structures significantly. The PbO₂ candle and sulfation plate test methods provide simple techniques to monitor SO₂ levels in the atmosphere independently to yield a weighted average result.

5.5 The results of these test methods are useful for characterizing atmospheric corrosion test sites regarding the effective average concentrations of SO₂ in the atmosphere at these locations.

5.6 These test methods are useful for determining microclimatic seasonal and long-term variations in effective average SO₂ concentrations.

5.7 The results of these test methods may be used in correlations of atmospheric corrosion rates with atmosphere data to determine the sensitivity of the corrosion rate to the SO₂ level.

5.8 These test methods may also be used with other test methods to characterize the atmosphere at sites at which buildings or other construction are planned in order to determine the extent of protective measures required for the materials of construction.

6. Apparatus

6.1 Test Method A:

6.1.1 *Lead Dioxide Candle*—An inert cylinder with a surface area of approximately 100 cm², covered with a fabric and coated with PbO₂ paste. See [Appendix X1](#) for preparation of the candle.

6.1.2 *Sampling Apparatus*—This may be a louvered enclosure, such as a cylinder or a rectangular box. If cylindrical, it shall be not less than 20-cm [8-in.] high and 18-cm [7-in.] in diameter; if rectangular, it shall be not less than 20 by 20 by 20 cm [8 by 8 by 8 in.]. Position the louvers at an angle of π/4 (45°) to provide maximum protection from the rain. Construct the enclosure of an inert material, such as plastic or wood. Do not coat the enclosure with a lead based paint. The sampling apparatus shall have provisions to hold the PbO₂ candle in a vertical position.

6.2 Test Method B:

6.2.1 *Sulfation Plate*—A polystyrene or polycarbonate culture (petri) dish, 50 or 60 mm in diameter, containing a filter paper disc, coated with PbO₂ paste. See [Appendix X2](#) for preparation of the sulfation plate.

6.2.2 *Bracket*, to hold the plates securely in an inverted position so that the PbO₂ mixture faces downward. The bracket design shall include a retaining clip or other provision to hold the plate in the event of strong winds. The retainer clip may be made from stainless steel, spring bronze, hard aluminum alloy (3003H19), or other alloys with sufficient strength and atmospheric corrosion resistance. A typical bracket design is shown in [Fig. 1](#).

7. Reagents and Materials

7.1 *Purity of Reagents*—Reagent grade chemicals shall be used in all tests. All reagents shall conform to the specifications of the Committee on Analytical Reagents of the American Chemical Society, except where such reagents are not available.⁵

7.2 *Purity of Water*—References to water shall be understood to mean reagent water as defined by Type II of Specification [D1193](#).

7.3 *Acetone*—Reagent grade.

7.4 *Barium Chloride Solution* (50 g/L)—Dissolve 59 g of barium chloride dihydrate (BaCl₂ × 2H₂O) in water and dilute to 1 L.

7.5 *Ethyl Alcohol* (95 %).

7.6 *Gum Tragacanth*, powdered.

7.7 *Hydrochloric Acid* (sp gr 1.19)—Concentrated hydrochloric acid (HCl).

7.8 *Hydrochloric Acid* (2 N)—Dilute 171 mL of concentrated HCl to 1 L.

7.9 *Hydrochloric Acid* (0.05 N)—Dilute 25 mL of 2 N HCl to 1 L.

7.10 *Lead Dioxide (Powdered)*—PbO₂ of the highest purity.

7.11 *Sodium Carbonate Solution* (83.3 g/L)—Dissolve 83.3 g of anhydrous sodium carbonate (Na₂CO₃) in water and dilute to 1 L.

⁵ *Reagent Chemicals, American Chemical Society Specifications*, American Chemical Society, Washington, DC. For suggestions on the testing of reagents not listed by the American Chemical Society, see *Analar Standards for Laboratory Chemicals*, BDH Ltd., Poole, Dorset, U.K., and the *United States Pharmacopeia and National Formulary*, U.S. Pharmacopeial Convention, Inc. (USPC), Rockville, MD.

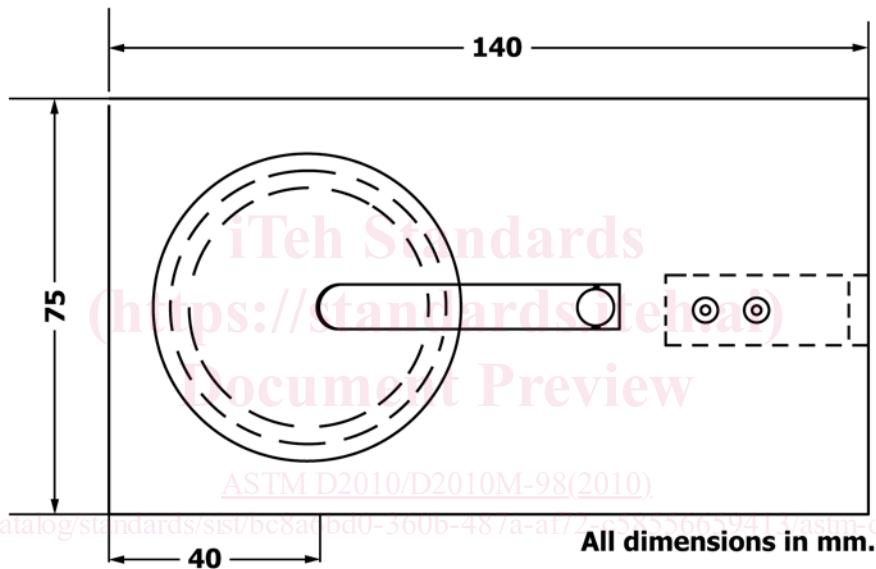
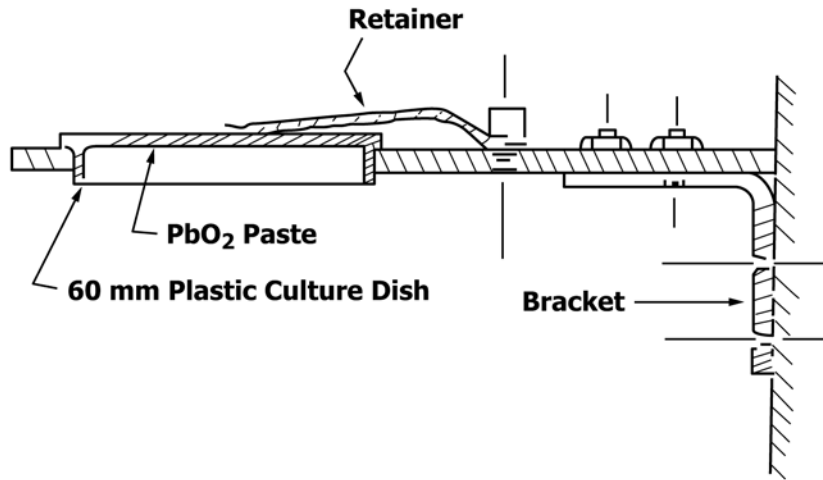

FIG. 1 Sulfation Plate Holder

7.12 *Methyl Orange Indicator* (0.1 %)—Dissolve 100 mg in water and dilute to 100 mL.

8. Precautions

8.1 *Safety Precautions*—Since lead is a toxic material, prepare and analyze the PbO_2 candles and sulfation plates under a fume hood, or with a respirator approved for use with toxic dusts.

8.2 PbO_2 , which is a strong oxidizing agent, can permeate and contaminate any laboratory area, making it impossible for use in conducting analysis of environmental samples for lead. Therefore, use a dedicated room that is well ventilated to the outside for the PbO_2 candle or sulfation plate work.

9. Sampling

9.1 Refer to Practice **D1357** for guidance in planning sampling programs.

9.2 When these test methods are used for estimating the SO_2 concentration over a designated area, select sampling stations at random on a uniform network grid over the area to be studied. The density of the sampling stations shall not be less than $1/km^2$ [$2/mile^2$].

9.3 *Location of Sampling Device*—Locate the box or bracket in a manner that will ensure protection from tampering and security from falling. The height from ground level shall be the same at all stations. The minimum height above the supporting surface shall be 1 m [3 ft]. The sulfation plate shall be horizontal and placed so that it is not protected from normal winds and air currents.

9.4 The sampling period may be 1 month or long enough to provide a convenient minimum of total sulfate for analysis. The work of Keagy (5), which is used as the criterion for the sampling procedure for candles, shows a range from 5 to 2000 mg of barium sulfate ($BaSO_4$) per candle. The sampling