



SLOVENSKI STANDARD

SIST ISO 2646:1995

01-december-1995

Volna - Določanje dolžine vlaken, predelanih po česalnem postopku, z aparatom za izdelavo dolžinskega diagrama

Wool -- Measurement of the length of fibres processed on the worsted system, using a fibre diagram machine

iTeh STANDARD PREVIEW

Laine -- Mesurage de la longueur des fibres travaillées sur système "laine peignée", par un appareil donnant un graphique de distribution de longueur des fibres

[SIST ISO 2646:1995](https://standards.itih.ai/catalog/standards/sist/21877167-1db4-4c20-8986-4662b001fc28/sist-iso-2646-1995)

Ta slovenski standard je istoveten z: **ISO 2646:1974**

ICS:

59.060.10 Naravna vlakna Natural fibres

SIST ISO 2646:1995 **en**

iTeh STANDARD PREVIEW
(standards.iteh.ai)

SIST ISO 2646:1995

<https://standards.iteh.ai/catalog/standards/sist/21877167-1db4-4c20-8986-46b2b001fc28/sist-iso-2646-1995>

INTERNATIONAL STANDARD 2646

INTERNATIONAL ORGANIZATION FOR STANDARDIZATION · МЕЖДУНАРОДНАЯ ОРГАНИЗАЦИЯ ПО СТАНДАРТИЗАЦИИ · ORGANISATION INTERNATIONALE DE NORMALISATION

Wool — Measurement of the length of fibres processed on the worsted system, using a fibre diagram machine

Laine — Mesurage de la longueur des fibres travaillées sur système «laine peignée», par un appareil donnant un graphique de distribution de longueur des fibres

First edition — 1974-07-01

iTeh STANDARD PREVIEW
(standards.iteh.ai)

[SIST ISO 2646:1995](https://standards.iteh.ai/catalog/standards/sist/21877167-1db4-4c20-8986-46b2b001fc28/sist-iso-2646-1995)

<https://standards.iteh.ai/catalog/standards/sist/21877167-1db4-4c20-8986-46b2b001fc28/sist-iso-2646-1995>

UDC 677.3-49 : 678.674-49 : 531.716 : 621.3.082.722,55

Ref. No. ISO 2646-1974 (E)

Descriptors : fibres, animal fibres, wool fibres, dimensional measurement, length.

FOREWORD

ISO (the International Organization for Standardization) is a worldwide federation of national standards institutes (ISO Member Bodies). The work of developing International Standards is carried out through ISO Technical Committees. Every Member Body interested in a subject for which a Technical Committee has been set up has the right to be represented on that Committee. International organizations, governmental and non-governmental, in liaison with ISO, also take part in the work.

Draft International Standards adopted by the Technical Committees are circulated to the Member Bodies for approval before their acceptance as International Standards by the ISO Council.

International Standard ISO 2646 was drawn up by Technical Committee ISO/TC 38, *Textiles*, and circulated to the Member Bodies in April 1972.

It has been approved by the Member Bodies of the following countries :

Belgium	Iran	South Africa, Rep. of
Brazil	Ireland	Spain
Canada	Israel	Sweden
Chile	Italy	Switzerland
Czechoslovakia	Japan	Thailand
Egypt, Arab Rep. of	New Zealand	Turkey
Finland	Pakistan	United Kingdom
Germany	Poland	U.S.S.R.
Hungary	Portugal	
India	Romania	

The Member Body of the following country expressed disapproval of the document :

France

This International Standard is based on the IWTO Test Method 16-67, drawn up by the International Wool Textile Organization (IWTO).

Wool – Measurement of the length of fibres processed on the worsted system, using a fibre diagram machine

1 SCOPE AND FIELD OF APPLICATION

This International Standard specifies a method for the measurement of the length of wool fibres using a fibre diagram machine. The method is applicable to combed slivers processed on the worsted system. For slivers containing two or more fibres of different dielectric constants (for example wool and polyester) and length distributions, the results may not be an accurate reflection of the actual fibre-length distribution of the top.

2 REFERENCE

ISO 139, *Textiles – Standard atmospheres for conditioning and testing*.

3 PRINCIPLE

A length of sliver under test is folded in two and squared off. A band of fibre ends is sealed to a plastic strip and withdrawn. The draw is then fed through the electrodes of a capacitance bridge in the apparatus and the position of a spot of light marked on recording paper, thus giving an estimate of the cumulative length distribution (hauteur).

4 APPARATUS

4.1 Sealing unit

The unit comprises the following main parts and accessories :

- trough with sliver clamp;
- hand-grip for squaring sliver;
- sealing film;
- roll of plastic strip;
- punch for making a hole 23,8 mm from aligned ends of fibres;
- thermostatically controlled heating element 3 mm wide on welding arm.

4.2 Fibre diagram machine

The main parts and accessories are as follows :

- transparent recording table of overall width 22,9 cm between edges;
- input platform with velvet strip for tensioning fibre draw;
- R.F. bridge electrode system working into tuned amplifier giving linear output;
- optical system giving deflection or recording image proportional to mass of fibre between electrodes;
- tension clip of mass between 1,5 and 3 g;
- small brush (see figure 1);
- recording paper graduated in millimetres horizontally and vertically from 0,20 cm.

A suitable machine is described in the annex.

5 ATMOSPHERE FOR CONDITIONING AND TESTING

The fibres shall be conditioned and the test shall be conducted in one of the standard atmospheres defined in ISO 139.

6 TEST SPECIMENS

6.1 Number of specimens

Unless otherwise stated, prepare and test four specimens from one sample of sliver.

6.2 Squaring the sliver

Take a length of sliver about 150 cm in length with pulled ends. Remove the presser and sliver clamp from the trough, insert the doubled thickness of sliver in the sliver clamp near the fold and screw up. Replace the sliver clamp in the slots and dispose the two layers of sliver in the trough so that the pulled ends project about 1 cm over the front edge of the slide. Smooth down the sliver with the fingers and insert the presser at the front of the trough.

ISO 2646-1974 (E)

Take the hand-grip and use it to remove and discard successive 2 mm bands of fibre ends. Continue squaring until a short distance beyond the squaring line marked on the slide.

6.3 Preparing the draw

Rotate the trough control until the aligned fibre ends are opposite the red arrow on the right of the slide. Cut two 19 cm lengths of plastic strip and slide one strip under the squared end of sliver until the end is at the black line (i.e. the plastic strip projects 3 mm under the fibre ends).

Take the second plastic strip, place it over the first so that its end covers the squared end of sliver and is opposite the black line, then place the sealing film over the ends of the plastic strips.

Move the welding arm down the slot so that the heating element presses on the sealing film. Keep up slight pressure for 10 to 15 s, then raise the welding arm, allow about 30 s to cool and peel back the sealing film from the plastic strip.

Free the plastic strips from the slide and pull in line with the trough, then cut away the upper plastic strip about 2 cm from the aligned fibre ends.

Place the sealed draw between the guide of the punch so that the aligned fibre ends, visible through the plastic strip, are opposite the index line, and depress the punch, thus making a hole 23,8 mm from the aligned fibre ends. Before preparing a second fibre draw from the same squared end of sliver, remove and discard about three bands of fibre ends.

6.4 Conditioning

Condition the prepared specimens before testing in the standard atmosphere specified in section 5, until they are in equilibrium with that atmosphere. If the test specimen is well opened out, conditioning for 1 h is generally sufficient to achieve a state of equilibrium.

7 PROCEDURE

Conduct all fibre measurements in the standard atmosphere specified in clause 5.

7.1 Insert a sheet of recording paper between the curved plates of the recording table, switch on the recording light and rotate the left-hand knob until the V-point of the recording image is exactly on the line 10 mm from the zero of the percentage axis.

7.2 If necessary, move the galvo lever until the V-point of the recording image is on the length axis of the recording paper. Move the TEST/ZERO switch to ZERO and, whilst holding it in this position, rotate the SET/ZERO dial until the V-point of the recording image is on the length axis of the recording paper.

7.3 Release the TEST/ZERO switch to OFF position.

7.4 Insert the prepared specimen between the cover and velvet of the input platform so that the short plastic strip is uppermost. Move the plastic strip forward with the fingers until the leading edge of the strip enters the electrode guard and cannot be pushed further.

7.5 Rotate the right-hand knob, driving the specimen forward, and ensure that the short plastic strip does not catch as it enters the input platform.

7.6 When the end of plastic strip has nearly reached the end of the output slide, attach the tension clip. Brush the exposed fibres on the input platform lightly towards the front. Rotate the right-hand knob and look through the front of the illuminated prism for the appearance of the index hole. Stop the rotation of the right-hand knob when the index hole lies exactly across the reference line.

7.7 If the hole is inadvertently moved beyond the reference line, the specimen must be completely removed by rotating the right-hand knob, and re-inserted.

7.8 Switch the TEST/ZERO switch to TEST and rotate the SET MAX. dial until the V-point of the recording image is on the black line at 97%. With a pencil, record the position of the V-point of the recording image.

7.9 Rotate the left-hand knob in steps of 5 mm and record the position of the V-point of the recording image until it is within 2 mm of the length axis.

7.10 Rotate the left-hand knob until the end of the longest fibre in the specimen is seen to be at the edge of the electrode guard. Record its position by making a mark through the Longest-Fibre hole with the pencil.

7.11 Move the ratchet lever forward and rotate the left-hand knob until the recording paper and specimen are released from the instrument. Move the TEST/ZERO switch to the OFF position ready for the next test.

8 CALCULATION AND EXPRESSION OF RESULTS

8.1 For each specimen, draw a smooth curve through the marks on the recording paper and read off and record the length ordinates corresponding to 5 %, 15 %, 25 % . . . 95 % (ten values). Calculate the mean of the values and record this as the mean length (hauteur) for each specimen.

Calculate the average hauteur for all specimens tested.

8.2 From the ten values of length recorded for each specimen, calculate the average and, using these, draw an average cumulative distribution to the same scale as that for individual specimens.

8.3 From the ten values of length X recorded in 8.2, calculate the coefficient of variation CV of hauteur using the formula

$$CV \% = 100 \sqrt{\frac{10 \sum X^2}{(\sum X)^2} - 1}$$

8.4 From the results of 8.1 and 8.3, calculate the average barbe as follows :

$$\text{Average barbe} = \text{average hauteur} \left[1 + \left(\frac{CV}{100} \right)^2 \right]$$

iTeh STANDARD PREVIEW
(standards.iteh.ai)

SIST ISO 2646:1995

<https://standards.iteh.ai/catalog/standards/sist/21877167-1db4-4c20-8986-46b2b001fc28/sist-iso-2646-1995>

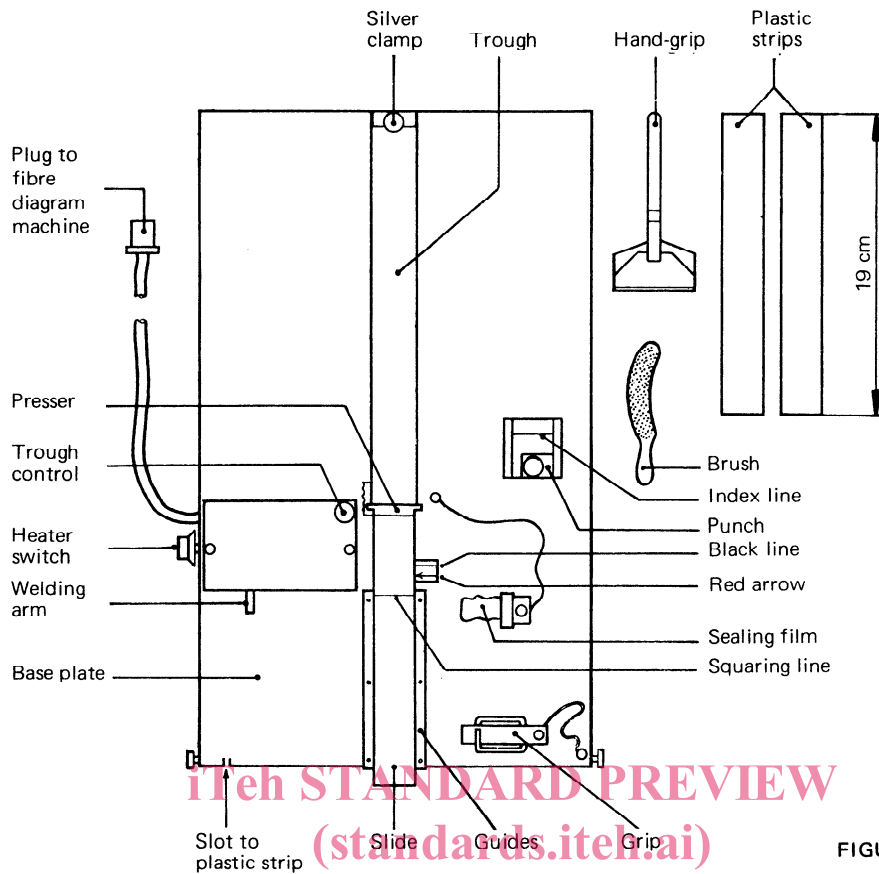

FIGURE 1 — Sealing unit

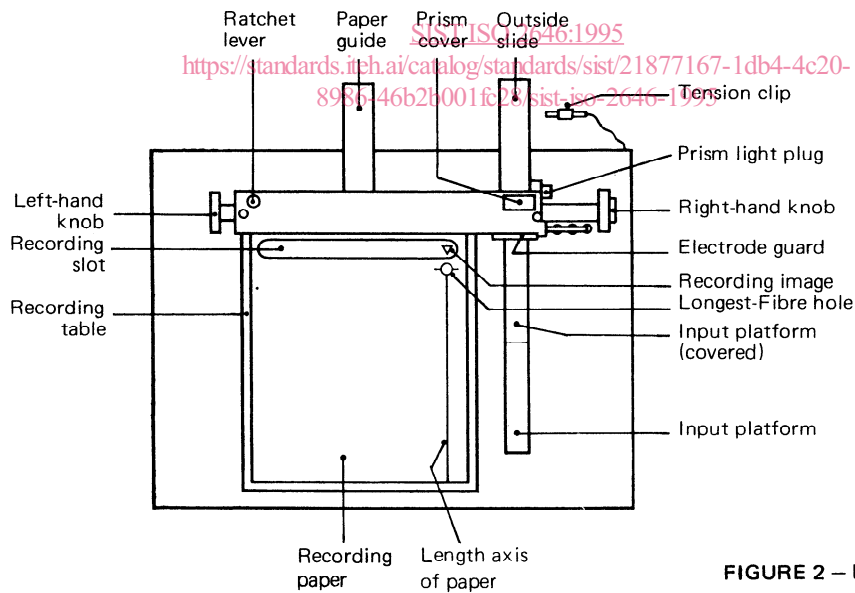

FIGURE 2 — Plan view of diagram machine

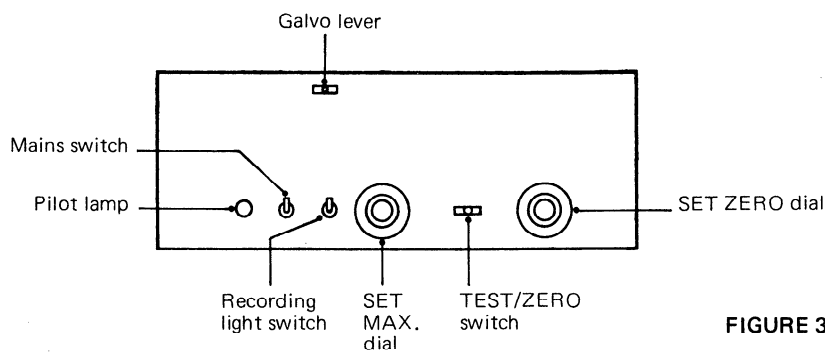

FIGURE 3 — Front face of diagram machine