



Designation: ~~C717-11~~ Designation: C717 – 11a

## Standard Terminology of Building Seals and Sealants<sup>1</sup>

This standard is issued under the fixed designation C717; the number immediately following the designation indicates the year of original adoption or, in the case of revision, the year of last revision. A number in parentheses indicates the year of last reapproval. A superscript epsilon ( $\epsilon$ ) indicates an editorial change since the last revision or reapproval.

### 1. Scope

1.1 This standard describes terms and definitions and descriptions of terms used or likely to be used in test methods, specifications, guides, and practices (related to building seals and sealants) consistent with the scope and areas of interest of ASTM Committee C24.

1.2 Definitions and descriptions of terms are written to ensure that building seals and sealants standards are properly understood and interpreted.

### 2. Referenced Documents

#### 2.1 ASTM Standards:<sup>2</sup>

- A644 Terminology Relating to Iron Castings
- C509 Specification for Elastomeric Cellular Preformed Gasket and Sealing Material
- C542 Specification for Lock-Strip Gaskets
- C716 Specification for Installing Lock-Strip Gaskets and Infill Glazing Materials
- C790 Guide for Use of Latex Sealants<sup>3</sup>
- C797 Practices for Use of Oil- and Resin-Based Putty and Glazing Compounds
- C961 Test Method for Lap Shear Strength of Sealants
- C964 Guide for Lock-Strip Gasket Glazing
- C1021 Practice for Laboratories Engaged in Testing of Building Sealants
- C1193 Guide for Use of Joint Sealants
- D883 Terminology Relating to Plastics
- D1079 Terminology Relating to Roofing and Waterproofing
- D1565 Specification for Flexible Cellular Materials—Vinyl Chloride Polymers and Copolymers (Open-Cell Foam)<sup>3</sup>
- D1566 Terminology Relating to Rubber
- D2102 Test Method for Shrinkage of Textile Fibers (Bundle Test)
- E631 Terminology of Building Constructions

### 3. Significance and Use

#### 3.1 Definitions:

3.1.1 Terms and their related standard definitions in Section 4 are intended for use uniformly and consistently in all building seals and sealants test methods, specifications, guides, and practices. The purpose of such use is to promote a clear understanding and interpretation of the standards in which they are used.

3.1.2 Definitions of terms are written in the broadest sense possible, consistent with the intended meaning. Definitions have not been limited to a specific technical field when they can have a multi-field application.

3.1.3 The definition of a term that can have different meanings in different technical fields is preceded by a phrase limiting it to the specific field intended, that is, “in building construction.”

#### 3.2 Description of Terms:

<sup>1</sup> This terminology is under the jurisdiction of ASTM Committee C24 on Building Seals and Sealants and is the direct responsibility of Subcommittee C24.01 on Terminology of Building Seals and Sealants.

The boldface designations refer to the original source of the definition and the ASTM Technical Committee having jurisdiction.

~~Current edition approved Jan. 15, 2011. Published February 2011. Originally approved in 1972. Last previous edition approved in 2010 as C717-10<sup>1</sup>. DOI: 10.1520/C0717-11.~~

Current edition approved March 1, 2011. Published March 2011. Originally approved in 1972. Last previous edition approved in 2011 as C717-11. DOI: 10.1520/C0717-11A.

<sup>2</sup> For referenced ASTM standards, visit the ASTM website, [www.astm.org](http://www.astm.org), or contact ASTM Customer Service at [service@astm.org](mailto:service@astm.org). For *Annual Book of ASTM Standards* volume information, refer to the standard's Document Summary page on the ASTM website.

<sup>3</sup> Withdrawn. The last approved version of this historical standard is referenced on [www.astm.org](http://www.astm.org).

3.2.1 Descriptions of Terms are special purpose definitions intended to provide a precise understanding and interpretation of the seals and sealants standards in which they are used.

3.2.2 A specific description of a term is applicable to the standard or standards in which the term is described and used.

3.2.3 Each standard in which a term is used, in a specially defined manner, should list the term and its description under the subheading, descriptions of terms.

## 4. Terminology

### 4.1 Terms and Definitions:

**adhesion failure**, *n*—*in building construction*, failure of the bond between a sealant and a substrate.

DISCUSSION—This definition pertains to interfacial adhesion failure, a lack of bond at the interface between the materials. Interphasal adhesion failure, within the sealant or substrate near the interface, is less common and may appear to be interfacial without the use of magnification.

**adhesive failure**, *n*—use **adhesion failure** (preferred term).

**aerosol container, empty**, *n*—*in building construction*, an aerosol container is considered empty when the product flow reaches 0.5 g per second or less.

**back bedding**, *n*—See **bedding**.

**back putty**, *n*—See **bedding**.

**back-up material**—See **sealant backing**.

**bead**, *n*—*in building construction*, in sealants and glazing, a strip of applied sealant, glazing compound, or putty.

**bed**, *v*—*in building construction in glazing*, to apply a bead of sealant between a lite of glass or a panel and the stationary stops or sight bars of the sash or frame.

**bed**, *n*—See **bedding**.

**bedding**, *n*—*in building construction in glazing*, a bead of sealant applied between a lite of glass or a panel and the stationary stop or sight bar of the sash or frame. It is usually the first bead to be applied when setting glass or panels.

**bite**, *n*—*in building construction in glazing*, the effective structural contact dimension of a structural sealant. (See Fig. 1 and Fig. 2.)

**bloom**, *n*—*in building construction*, a substance formed by blooming.

**blooming**, *v*—*in building construction*, movement or diffusion of a component such as a plasticizer, monomer, unreacted polymer or other formulation ingredient to a sealant surface.

**bond breaker**—*in building construction*, a material to prevent adhesion at a designated interface. (Fig. 3.)

**caulk**, *v*—*in building construction*, to install or apply a sealant across or into a joint, crack, or crevice.

**caulk**, *n*—See **sealant**.

**caulking**, *n*—See **sealant**.

**caulking compound**, *n*—See **sealant**.

**cell**, *n*—a single small cavity surrounded partially or completely by walls. **D1566; D11**

**cellular material**, *n*—a generic term for materials containing many cells (either open, closed, or both) dispersed through the mass. **D1565, D1566; D11**

**chalk**, *n*—*in building construction*, a powder formed by chalking

DISCUSSION—The powder is not necessarily white.

**chalking**, *v*—*in building construction*, formation of a powder on the surface of a sealant that is caused by the disintegration of the polymer or binding medium due to weathering.

DISCUSSION—Chalk on a light color sealant is often white, however a darker color can also exhibit chalking.

**closed cell**, *n*—a cell totally enclosed by its walls and hence not interconnecting with other cells. **D883; D20**

**closed cell material**, *n*—a cellular material in which substantially all cells in the mass are closed cells.

**cohesive failure**, *n*—*in building construction*, failure characterized by rupture within the sealant, adhesive, or coating.

**compatibility**, *n*—*in building construction*, the capability of two or more materials to be placed in contact, or near enough to interact, with no detrimental results.

**compatible materials**, *n*—See **compatibility**.

**compound**, *n*—an intimate mixture of all the ingredients necessary for a finished material or product.

**crazed**, *adj*—*in building construction*, having a random network of cracks in a sealant surface which do not penetrate through the body of the material.

**crazed**, *adj*—*in building construction*, exhibiting crazing.

**crazing**, *n*—*in building construction*, a network of fine cracks in the surface of a sealant.

DISCUSSION—Crazing may or may not affect product performance.

**crazing**, *v*—*in building construction*, the formation of a network of random surface cracks in a sealant.

**creep**, *n*—the time dependent part of a strain resulting from stress. **D1079; D08**

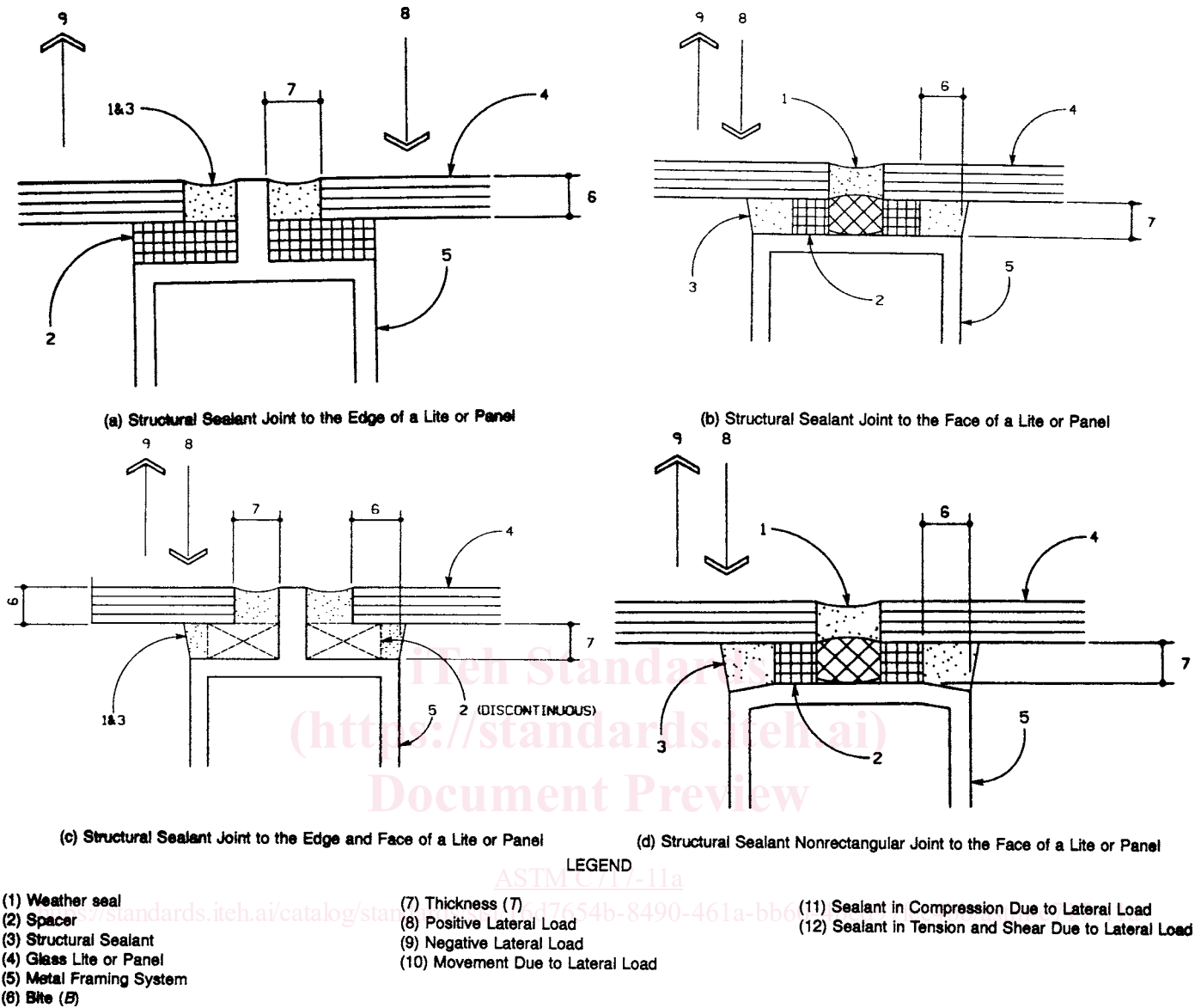

FIG. 1 Typical Structural Sealant Joint Configurations

**cure, v**—*in building construction*, to attain the intended performance properties of a compound by means of evaporation, chemical reaction, heat, radiation, or combinations thereof.

**cure, n**—*in building construction*, the process by which a compound attains its intended performance properties by means of evaporation, chemical reaction, heat, radiation, or combinations thereof.

**cured, adj**—*in building construction*, pertaining to the state of a compound that has attained its intended performance properties by means of evaporation, chemical reaction, heat, radiation, or combinations thereof.

**design life, n**— *in building construction*, the period of time after installation during which a seal or sealant is expected to perform its stated intended-function(s) with proper maintenance.

**DISCUSSION**—Proper maintenance includes, among others, replacement of discrete localized failures.

**dirt pick-up, n**— *in building construction*, soiling caused by a foreign material other than micro-organism growth that is deposited on, adhered to, or embedded into a sealant.

**DISCUSSION**—Micro-organism growth can produce a similar appearance.

**durability**—*in building construction*, the ability of a seal or sealant to perform its required functions over a period of time within the environment to which it is exposed.

**DISCUSSION**—A seal or sealant's required functions may include aesthetic, economic, and functional performance considerations, among others.

**durability limit, n**—see the preferred term, **service life**.

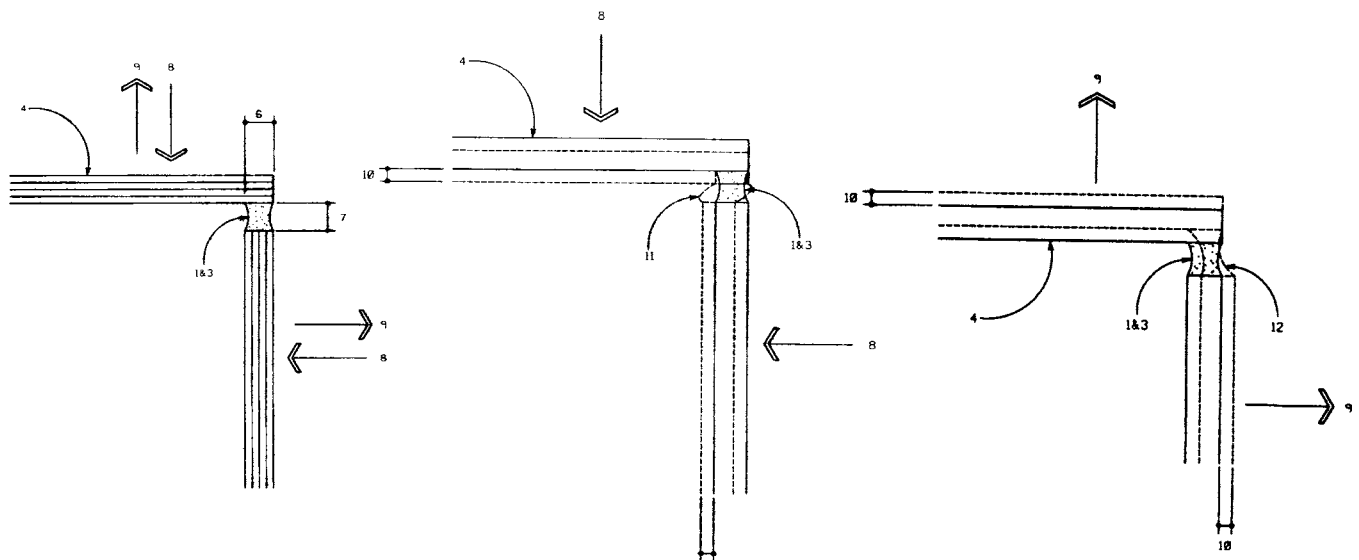

(a) Vertical Corner With One Lite or Panel Structurally Sealed to the Other

(b) Positive Applied Lateral Load

(c) Negative Applied Lateral Load

FIG. 2 Applied Load Transfer at a Vertical Corner Structural Sealant Joint (see Fig. 1 for Legend)

**elastomer, n**—for gaskets and couplings for plumbing and sewer piping, a macromolecular material that returns rapidly to approximately its original dimensions and shape after substantial deformation by a weak force and release of the force.

DISCUSSION—a) Elastomers are divided into two major polymer systems—thermoset and thermoplastic. b) In standards for rubber, the word elastomer is not to be used interchangeably for the term “rubber”.

D1566; D11

**elastomer, n**—in building construction in glazing, a macromolecular material, which deformed within its service temperature range, is capable of recovering substantially in size and shape after removal of a deforming force.

**elastomer, thermoplastic, n**—a material having the general properties of an elastomer and capable of being repeatedly softened by heat and hardened to shape by cooling without significant degradation of the polymer system.

DISCUSSION—Thermoplastic elastomers have some of the properties of thermoset elastomers, but are typically more thermally and pressure sensitive and more sensitive to solvents.

**elastomer, thermoset, n**—an elastomeric material that attains its intended properties by an irreversible cross-linking reaction caused by heat alone, heat with a cross-linking agent, chemical interaction, or by radiation; whereby after cross-linking, any reprocessing with heat and pressure will severely degrade the material.

DISCUSSION—Cross-linking renders the material substantially insoluble in organic solvents (can swell), less plastic, and with improved elastic and mechanical properties (compared to its uncured state) over an extended temperature range.

**elastomeric, adj**—having the characteristics of an elastomer.

**elongation, n**—extension produced by a tensile stress.

D1566; D11

**extrudability, n**—in building construction, the ability of a sealant under pressure to flow through an orifice.

**flow, v**—in building construction, the deformation of a tape sealant under stress.

**fluid migration, n**—in building construction, accumulation of a fluid from a sealant on or in an adjacent material.

DISCUSSION—Migration of a non-fluid component can also occur.

**gasket, n**—any preformed, deformable device designed to be placed between two adjoining parts to provide a seal.

**gasket, compression, n**—a gasket designed to be used under compression.

**gasket, lock-strip, n**—in building construction, a gasket in which sealing pressure is attained by inserting a keyed locking strip into a mating keyed groove in one face of the gasket.

**glazing, v**—in building construction, the installation of glass or other materials in prepared openings.

**glazing, butt, n**—in building construction, a glazing system wherein butt joints are formed between lites and filled with a glazing sealant.

**glazing, compression, n**—see **glazing system, compression**.

**glazing, compression, v**—in building construction, the act of installing components into a compression glazing system.

**glazing, construction site, n**—in building construction, the installation of glass or panels into a metal framing system, at a construction site, under generally uncontrolled environmental conditions.

**glazing, face, n**—the method of glazing in which a rabbeted glazing recess, with no removable stop, is used and a triangular bead of compound is applied to the face of the lite and extended onto the recess.

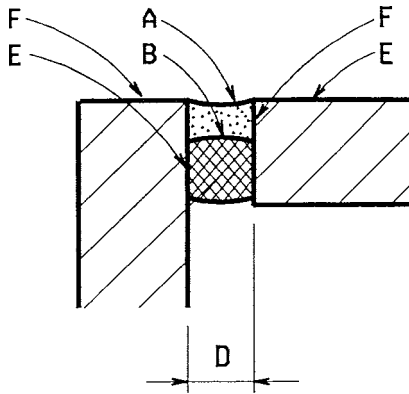

a. face to edge

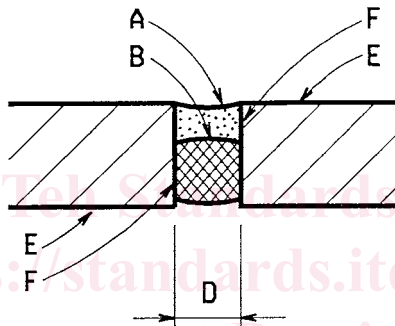

b. edge to edge

- A—Sealant
- B—Sealant backing
- C—Bond breaker
- D—Joint
- E—Substrate face
- F—Substrate edge

FIG. 3 Butt Sealant Joint

*glazing, factory, n*—See **glazing, shop**.

*glazing, field, n*—See **glazing, construction site**.

**glazing, four-side structural sealant, n**—*in building construction*, a glazing system wherein all sides of a rectangular-shaped lite or panel are structural sealant glazed.

**glazing, needle**—*in building construction*, the application of a small bead of a sealant at the sight line adhering to the sash and glass or panel by means of a nozzle with an orifice not exceeding 3.18 mm [ $\frac{1}{8}$  in.] in diameter.

*glazing, non-compression, n*—see **glazing system, non-compression**.

**glazing, non-compression, v**—*in building construction*, the act of installing components into a non-compression glazing system.

**glazing, protective, n**—*in building construction*, systems with glazed openings that are designed to mitigate the effects of bomb blasts, projectiles, natural disasters, or forced entry.

DISCUSSION—Protective glazing systems assist in the mitigation of the potential for hazardous debris dispersal from natural disasters, withstand projectile impact and resist unauthorized human entry through glazed openings. Protective glazing systems include the selection of an appropriate glazing material, the design of metal framing members and their anchorages, and the retention of the glazing material within the framing all to resist a specified threat.

**glazing, shop, n**—*in building construction*, the installation of glass or panels into a metal framing system under controlled environmental conditions.

DISCUSSION—Shop glazing typically occurs at a location remote to a construction site. However, shop glazing can be performed at the construction site if acceptable to the code authority and provided appropriate management controls and environmental conditions are maintained.

*glazing, stopless*—See **glazing, structural sealant**, the preferred term.



DISCUSSION—Inappropriately used to describe structural sealant glazing.

**glazing, structural sealant**, *n*—*in building construction*, a glazing system wherein a structural sealant is used to transfer loads between a lite or panel and a supporting framework, without mechanical fasteners or other methods of attachment.

**glazing, two-side structural sealant**, *n*—*in building construction*, a glazing system wherein two sides of a rectangular-shaped lite or panel, usually opposing, are structural sealant glazed.

**glazing compound**, *n*—*in building construction in glazing*, a putty material composed primarily of oil- or resin-based ingredients used for sealing window glass in frames.

DISCUSSION—Historically these compounds cure primarily through solvent evaporation, oxidation or both. Compounds other than oil- or resin-based can be used for glazing, though they may not have a putty-like consistency.

**glazing system, compression**, *n*—*in building construction*, gasket(s) or a combination of sealant(s) and gasket(s) used to provide weather-tightness by way of continuous pressure on the components in the joint.

**glazing system, non-compression**, *n*—*in building construction*, a sealant or combination of sealant(s) used to provide weather-tightness by way of the adhesive/cohesive characteristics of the components in the joint.

**gun-grade**, *n*—*in building construction*, a material of a suitable viscosity to extrude through the nozzle of a hand- or power-operated device.

**hardness**, *n*—*in building construction*, the resistance to indentation as measured under specified conditions. **A644; A04**

**hydrostatic pressure**, *n*—a state of stress in which all the principal stresses are equal (and there is no shear stress), as in a liquid at rest; the product of the unit weight of the liquid and the difference in elevation between the given point and the free liquid elevation.

**joint**, *n*—*in building construction*, the space or opening between two or more adjoining surfaces.

*joint, butt*, *n*—See **sealant joint, butt** (See Fig. 3).

**joint, construction**, *n*—*in building construction*, a formed or assembled joint at a predetermined location where two successive placements (“lifts”) of concrete meet.

DISCUSSION—Frequently a keyway or reinforcement is placed across the joint. With proper design, this joint may also function as a control or an isolation joint.

**joint, control**, *n*—*in building construction*, a formed, sawed, tooled, or assembled joint acting to regulate the location and degree of cracking and separation resulting from the dimensional change of different elements of a structure.

DISCUSSION—The joint is usually installed in concrete and concrete masonry construction to induce controlled cracking at preselected locations or where a concentration of stresses is expected.

**joint, expansion**, *n*—*in building construction*, a formed or assembled joint at a predetermined location, which prevent the transfer of forces across the joint as a result of movement or dimensional change of different elements of a structure or building.

*joint, fillet bead*, *n*—Use **sealant joint, fillet** (preferred term) (See Fig. 4).

**joint, isolation**, *n*—*in building construction*, a formed or assembled joint specifically intended to separate and prevent the bonding of one element of a structure to another and having little or no transference of movement or vibration across the joint.

*joint backing*—See **sealant backing**.

**joint filler**, *n*—a compressible material used in a partial or totally filled expansion, control, or isolation joint by its permanent placement in or between building materials such as concrete or masonry during construction; sometimes used as a sealant backing in a partially filled joint.

**joint seal, expansion**, *n*—*in building construction*, a seal or sealant system that provides an elastic, compressible, or flexible barrier to the passage of gases, liquids, or solids.

**knife-grade**, *n*—*in building construction*, a compound of such consistency that it is generally applied with a knife or spatula hand tool.

**laitance**, *n*—*in building construction*, a weak layer of cement and aggregate fines on a concrete surface that is usually caused by an overwet mixture, overworking the mixture, improper or excessive finishing, or combinations thereof.

*light*, *n*—Use **lite** (preferred term).

**lite**, *n*—one piece of glazing (also spelled light), synonym: pane. **E631**

**modulus**, *n*—as related to sealants used in building construction, the stress (force/unit area) at a corresponding strain (elongation) expressed as a percent of the original dimension.

DISCUSSION—When the stress to strain values are expressed as a ratio, this describes the slope of a line tangent to the given point on the stress-strain curve. This is the tangent modulus.

**modulus, secant**—slope of the line connecting the origin and a given point of the stress-strain curve.

**modulus, tangent**, *n*—the slope of the line touching (tangent to) the stress-strain curve at a given point on the curve.

**muntin**, *n*—a secondary intermediate member subdividing a glazed area.

**necking**, *n*—*in building construction*, the localized reduction in cross section that may occur in a material under stress. **D883; D20**